

ARPER FOR EDUCATION

arper

CONTENTS

Arper for Education	5
Our company	6
Collections	14
On Educational Segment	23
Rethinking how and where we learn	59
More in depth, technical details	85

Arper on the Go

Scan the QR code to download the Arper app on your tablet and explore our world.



Arper for Education

As our communal spaces reopen and students return to schools, we need flexible solutions to accommodate the evolving needs of learning environments.

From individual workspaces to shared classrooms or libraries, we need modular furniture options that can be reconfigured to maintain a safe space. Arper's product offerings for the learning sector have always prioritized customization and adaptability, addressing the individual needs of students of all ages and the flexibility to meet the needs of the moment.

Arper

=

arredamento

(furniture)

+

per

(for)

We are a fast-growing company founded in 1989 — a family business guided by an integrative, human-centered approach. We have grown from a furniture manufacturing business to an international design presence, dramatically increasing our turnover and adding hundreds of new employees to the Arper family.

Structure

Arper capabilities:

- Three local production facilities, based in Italy (Treviso), US (High Point, North Carolina), and Japan allow us to ensure prompt delivery and assistance
- A global organization including 12 showrooms, 6 subsidiaries, 4 branches, 2 meeting hubs and a network of representatives guarantee a presence in over 90 countries
- Long-term partnerships with over 200 suppliers with unique expertise enable us to provide a full range of capabilities, from upholstery to metal work to carpentry
- Our product development team and sampling facilities are committed to research the latest innovations to be applied to our products

Structure

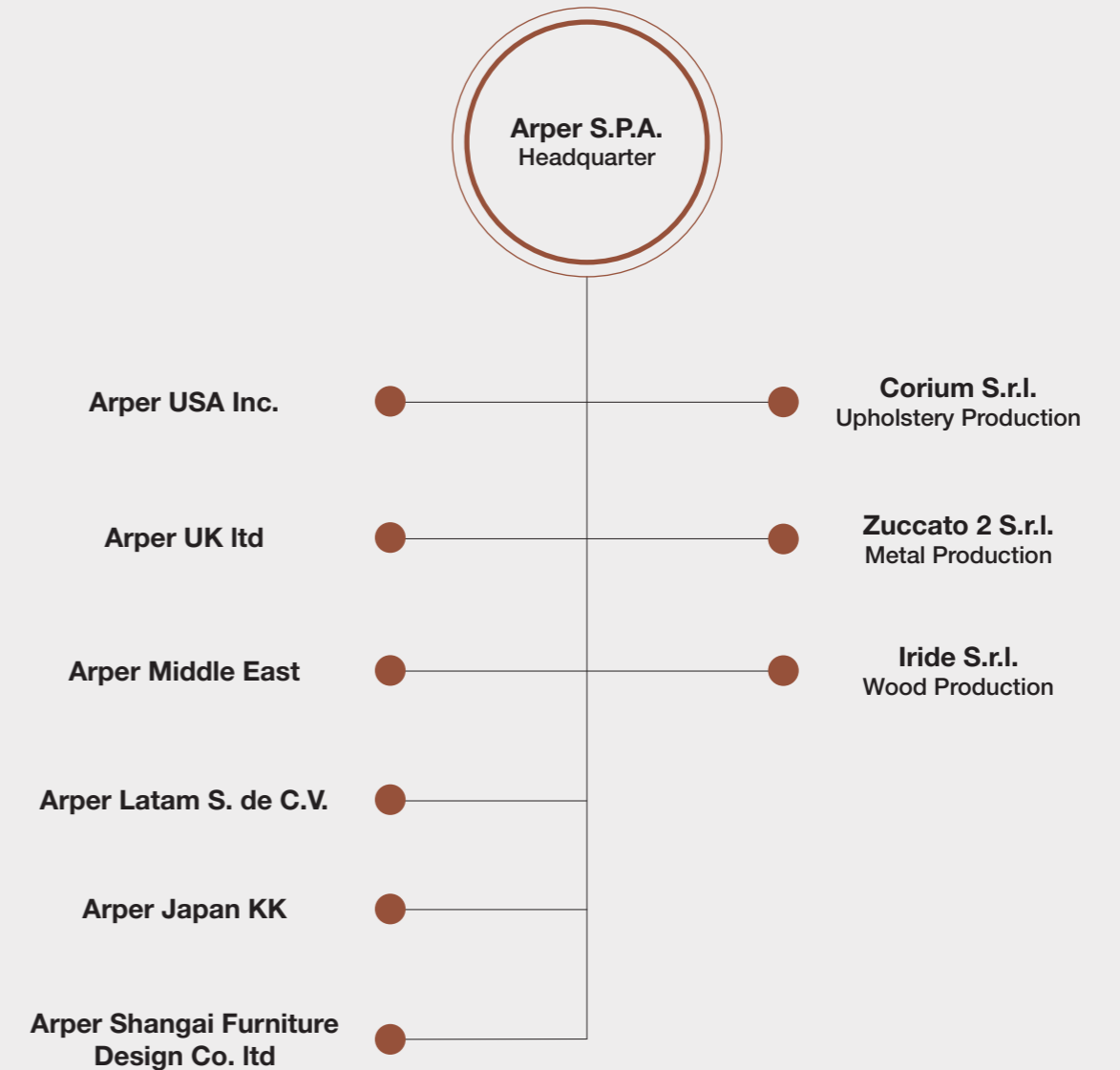

A network of 200 suppliers specialized in metal work, upholstery and carpentry

A global presence in over 90 countries

3 local production facilities

1 upholstery department based in Italy

ARPER GLOBAL PRESENCE:



An extensive network of dealers across 90 countries.
89% of our 2019 turnover came from export.

A TRADITION OF CRAFT AN EYE ON DESIGN

1989

Arper is established by the Feltrin family



1998

Arper meets Lievore Altherr Molina



2000

Arper moves away from furniture manufacturing to become a design-oriented company



2002

In-house upholstery



2005

Arper founds environmental department



2008

Opening of Arper USA, Inc.



Arper

2020

2010

Opening of the flagship showroom in Milan, first of 11 international showrooms



2012

Launch of Lina Bo Bardi project



2016

Opening of a subsidiary in Japan and of a showroom in Tokyo.



2014

Opening of warehouse and production facilities in North Carolina



2017

Opening of a branch and of a meeting hub in Belgium, and of a new factory in North Carolina



2018—present

Ongoing global expansion with the opening of a showroom in Los Angeles and of two subsidiaries in Mexico and China



Collections

Every part of the product development process—from design to production to long-term impact—is carefully considered, bringing function, aesthetic, detail together in elegant resolution.

We develop and manufacture custom solutions to complement our furniture range for applications in hospitality, work and home. We are proud to support customers and their partners in creating actionable solutions.



CHAIRS

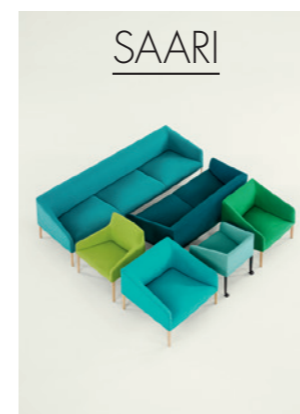
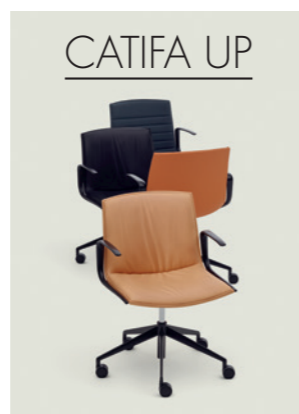
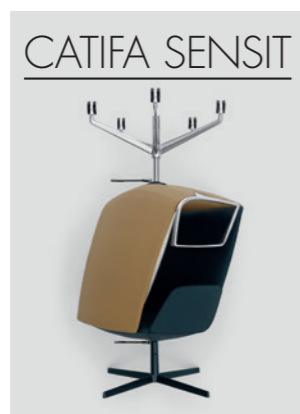
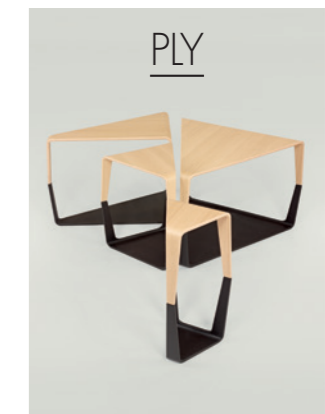
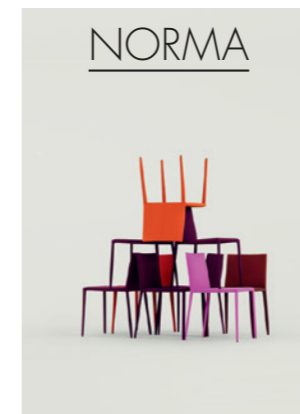
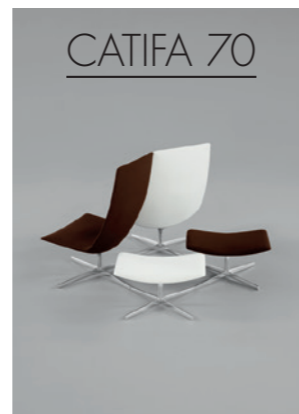
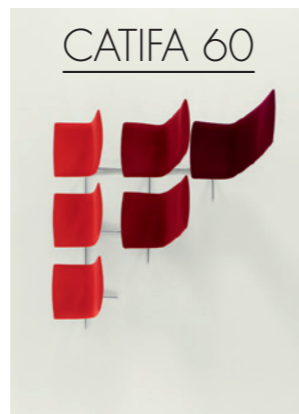
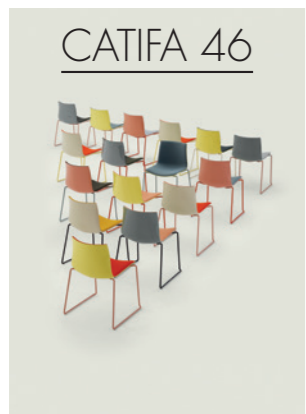
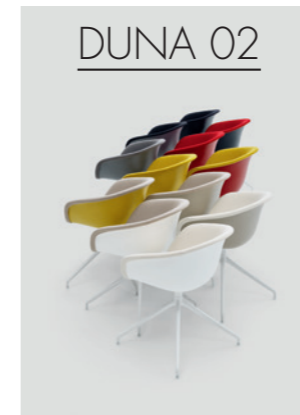
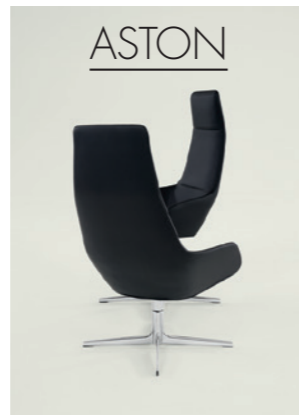
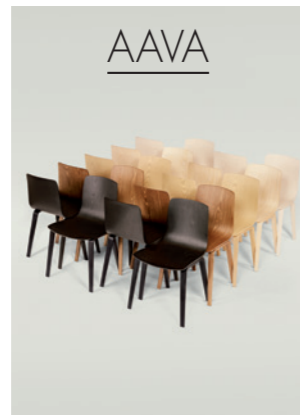

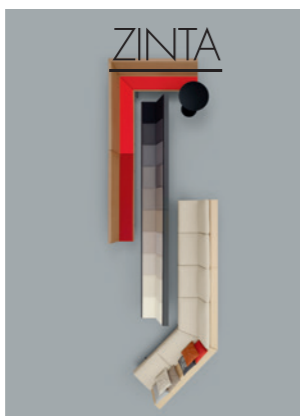
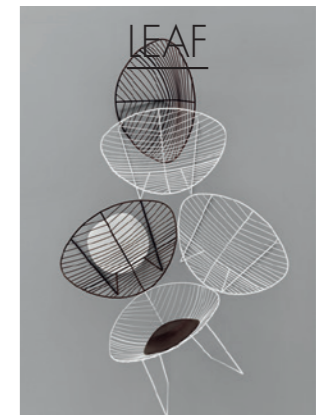
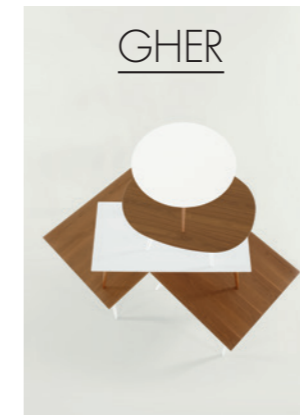
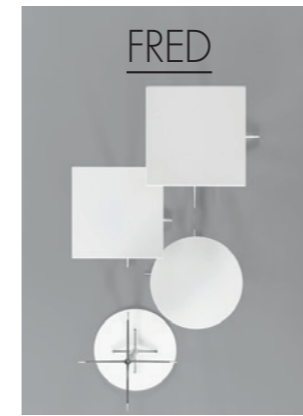
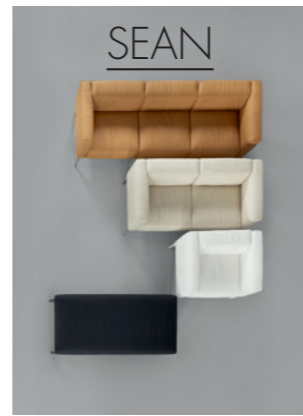
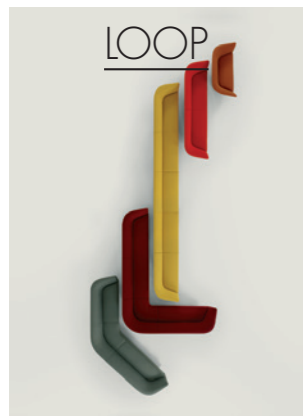
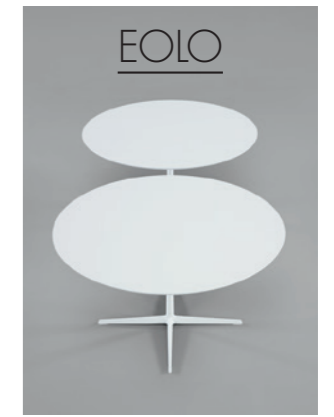
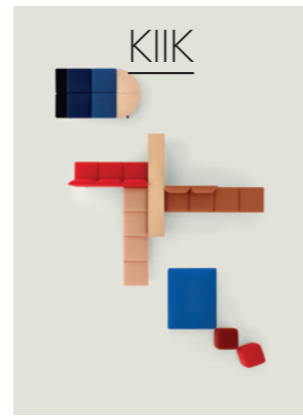
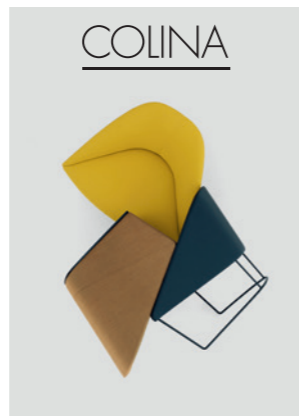
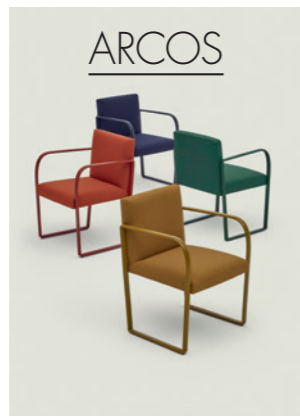

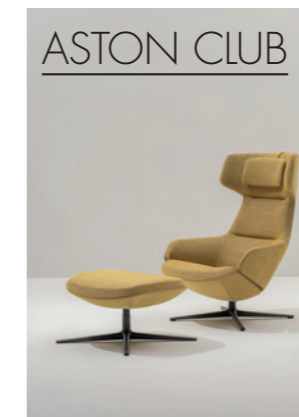
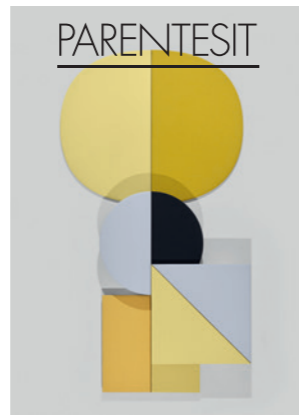
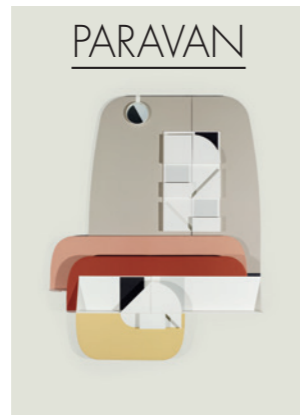
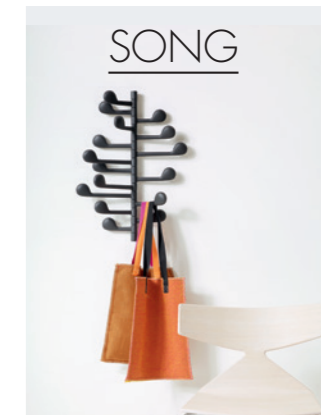

ON
EDUCATIONAL
SEGMENT

Royal College of Surgeons

Dublin / Ireland

- Architect:

Henry J Lyons Architects

- Photo:

Donal Murphy

- Arper products:

Aava, Catifa 46,

Colina, Duna 02, Juno

- Living / break out & lounge area

Arper



Selected References



Education



Arper

COLLABORATIVE STUDY ZONE

2

Education

**Harvard University
Smith Campus Center
Cambridge / USA**

- Architect:
Hopkins Architects,
Bruner/Cott Architects
- Photo:
Nic Lehoux
- Arper products:
Catifa 80, Pix
- Living / break out & lounge area

Arper



**Barnard College
The Milstein Center
New York / USA**

- Architect: SOM
- Photo: Magda Biernat
- Arper products: Aava
- Living / break out & lounge area



Selected References

Arper

Education

H-FARM

Treviso / Italy

- Photo: Marco Covi
- Arper products:
Leaf, Kinesit, Pix
- Conviviality / bar & cafeteria,
Learning / classroom,
Collaboration / workplace

Arper



Selected References



Education



Selected References



TU Delft
Faculty of Applied Sciences
Delft / The Netherlands

- Architect: Ector Hoogstad Architecten
- Photo: Hans Morren
- Arper products: Catifa 46
- Learning / reading room

Arper



Education



- Erasmus University College**
Rotterdam / The Netherlands
- Architect: Erick Van Egeraat
 - Photo: Ossip van Duivenbode
 - Arper products:
Catifa 46, Catifa 80
 - Collaboration / workplace

Arper



Selected References

- Haagsche Hogeschool
Delft / The Netherlands
- Architect: Syb van Breda,
Royal HaskoningDHV
- Photo: Hans Morren
- Arper products:
Catifa 46, Palm
- Learning / reading room

Arper



Education

**Georgetown University
School of Continuing Studies
Georgetown / USA**

- Architect: Studios Architecture
- Photo: Bruce Damonte
- Arper products:
Catifa 46, Catifa 80, Pix
- Living / lounge & break out area
Conviviality / bar & cafeteria

Arper



Selected References



Education

Ryerson University
Student Learning Centre
Toronto / Canada

- Architects: Zeidler Partnership Architects, Snøhetta
- Photo: doublespace photography, Lorne Bridgman
- Arper products: Catifa 80
- Living / lounge & break out area



Arper

Selected References



Université Paris-Sorbonne

Paris / France

- Architect: GPAA
- Photo: 11h45
- Arper products:
Catifa 46, Pix
- Learning / reading room



Kindergarten Susi Weigel
Bludenz / Austria
- Architects: Bernardo Bader Architekten
- Photo: Adolf Bereuter
- Arper products: Pix
- Living / lounge & break out area

Arper



Oodi Helsinki Central Library

Helsinki / Finland

– Architect:

ALA Architects

– Photo:

Tuomas Uusheimo

– Arper products:

Catifa Sensit, Saari



PEMA Tower Municipal Library

Innsbruck / Austria

- Architect:
LAAC Architekten
- Interior Design:
reiter design
- Photo:
Marc Lins
- Arper products:
Catifa 46, Catifa 53,
Meety, Nuur

Arper



Education



Arpe

Education

RETHINKING
HOW AND
WHERE
WE LEARN

Reimagined Spaces with Adaptability

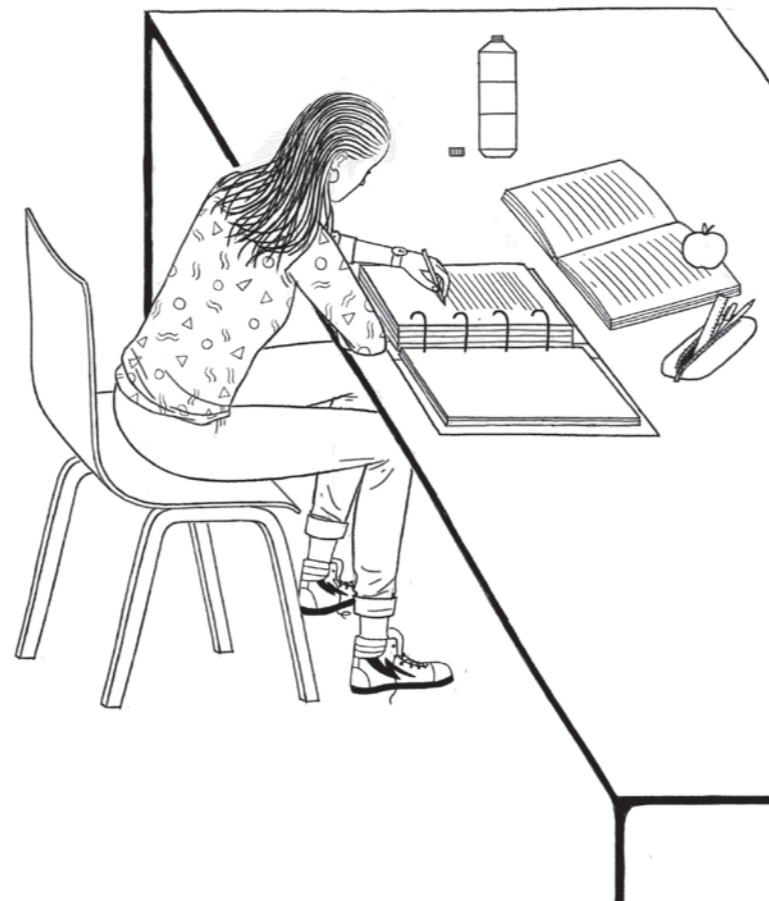
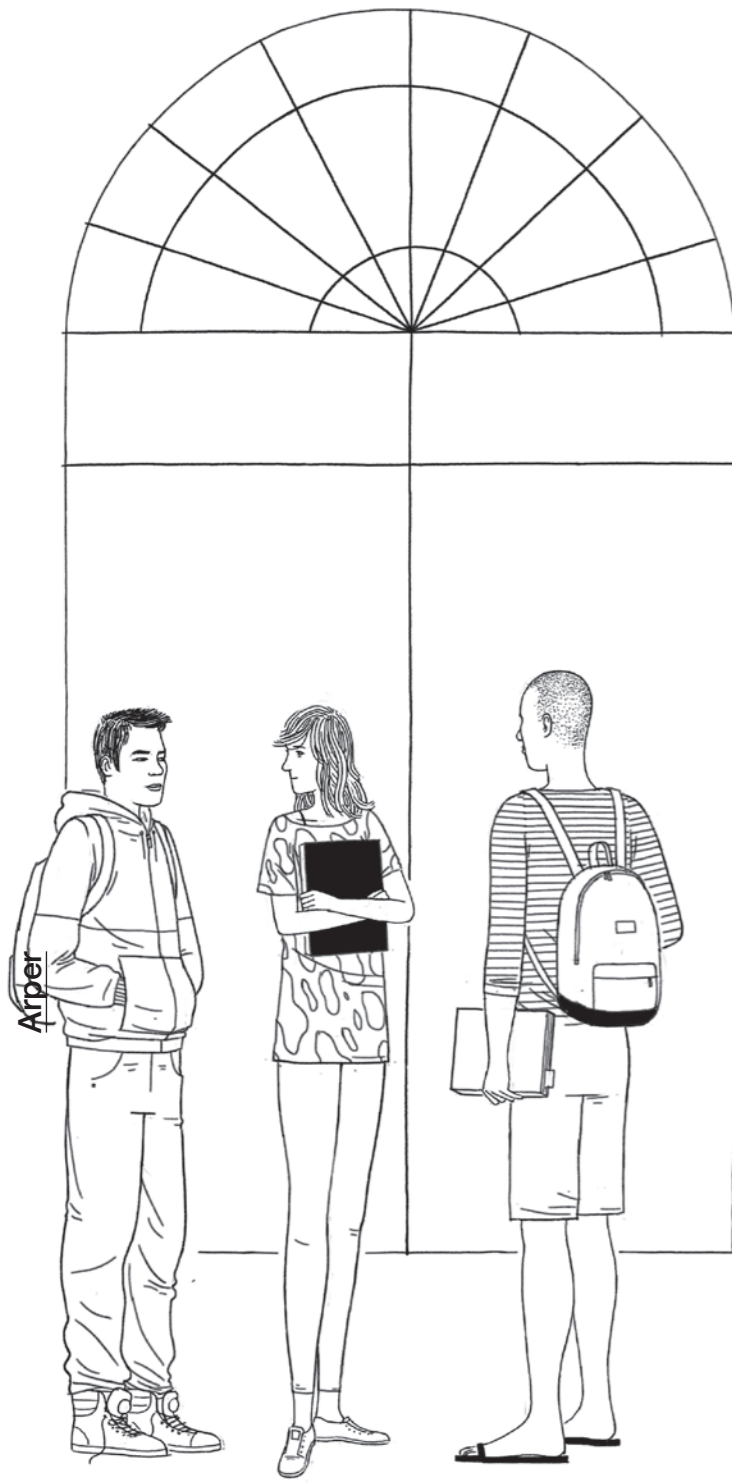

Arper has always put flexibility at the forefront of our designs and promoted a sense of balance between work and personal life.

In the following proposals, we have taken some of our favorite designs and explored how they can be personalized and modified to adjust to the evolving needs of this time. With a core value of adaptability, Arper has created flexible furniture to meet the demands of the moment—and every moment to come.

Lobby Area

Public learning areas like lobbies can present an opportunity to rest, recharge, read, or meet in small groups—but at a safe distance. This configuration of Kiik makes the space between seating functional with a small, useful table.

Arper



Education

Break Out Room

Break out areas are essential as informal places to work and exchange ideas. Paravan helps maintain creativity and an exchange of ideas while still safeguarding the space. Cross's expansive tabletop allows for up to 4 individuals at a table while still maintaining safe distancing practices.



Laboratory

Laboratory work stations can increase opportunities for focus and safety with Paravan panels which help to reduce noise as well as keep a safe distance. Here Planesit task chairs and Nuur table combine to create a flexible space to learn.



Co-Working

Paravan Mood can be used as a desk divider, as seen here with the spacious Cross table and Planesit stools. Used together, these offerings provide safe working spaces while still maintaining a sense of exchange and camaraderie.

Arper



Reimagined Spaces with Adaptability

Education

Collaborative work

Individual or small group learning is made possible by Cila Go – an armchair with optional built-in desk or castors. This compact piece is virtually a mobile classroom, all in one chair that can be easily moved, cleaned, and used as storage.





Reimagined Spaces with Adaptability

Arper

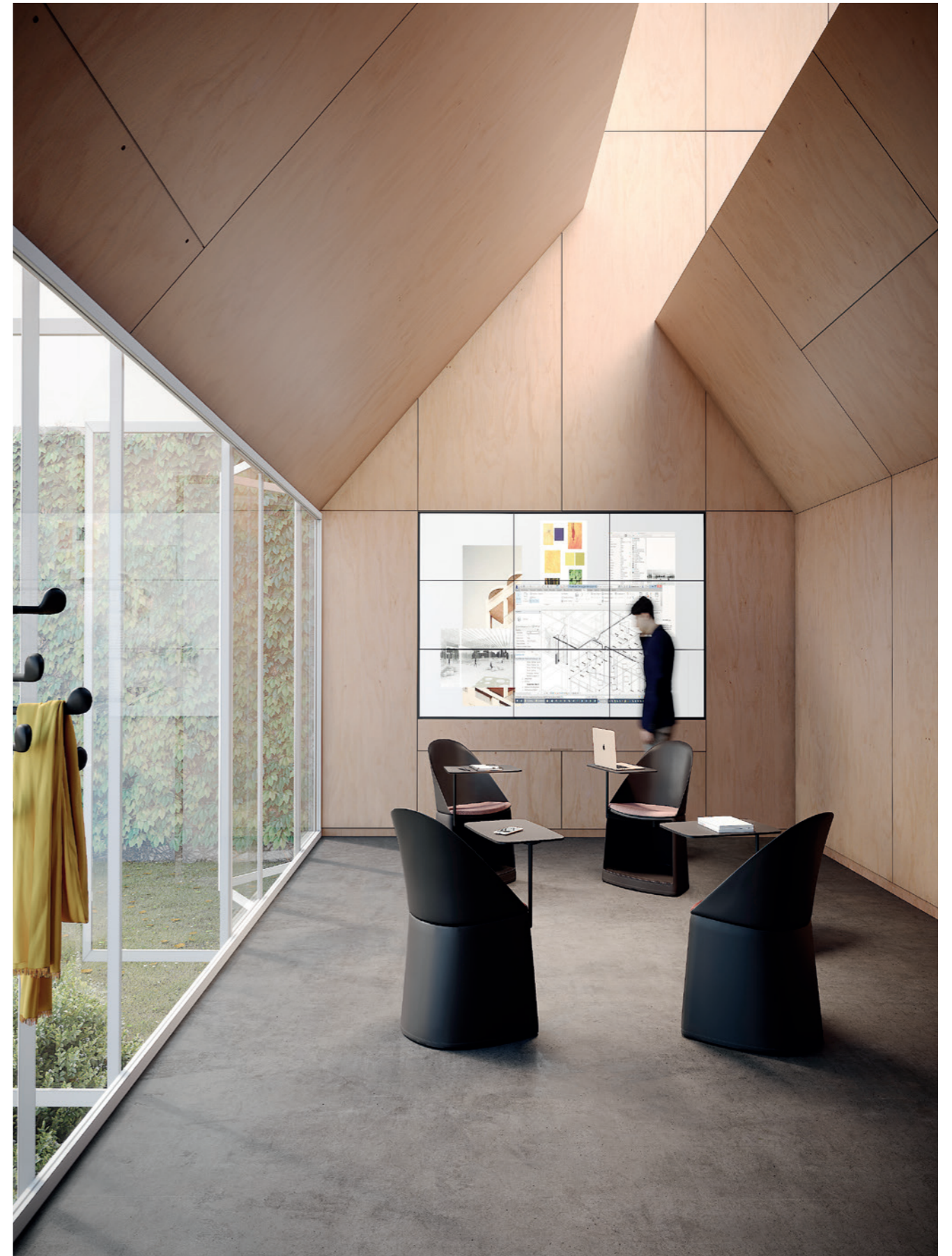

Education

Auditorium

For large groups or auditoriums, Stacy chair, thanks to its light weight, ease of movement and a tablet that can be used as a desk, guarantees the possibility of fast reconfiguration within the space, maintaining an adequate safe distances.



Cafeteria

Communal dining helps foster an exchange of ideas and learning. In our new era, maintaining effective distance is key. Spaced apart but easy to rearrange, these Catifa chairs are lightweight yet durable making them a breeze to reconfigure as needed.

Arper



Reimagined Spaces with Adaptability



Education

Outdoor Areas

Outdoor areas provide a space for conversation and relaxation. Adell, one of our newest collections, helps to confer a comfortable atmosphere and can be rearranged as needed to meet the demands of the moment.



Reimagined Spaces with Adaptability

Arper

Education



MORE
IN DEPTH,
TECHNICAL
DETAILS

Kiik Collection overview
 (For more information please refer to User's Manual downloadable from our website)

Structure

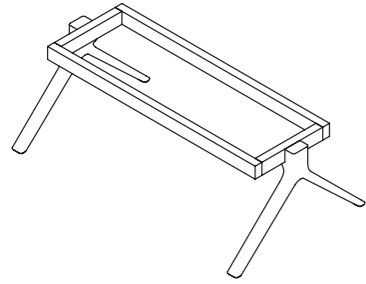

Art. 6302 – S126
 — Dimensions: 92,6x33x35 cm
 — Dimensions of complete item: 126x63 cm
 — Fills 2 units

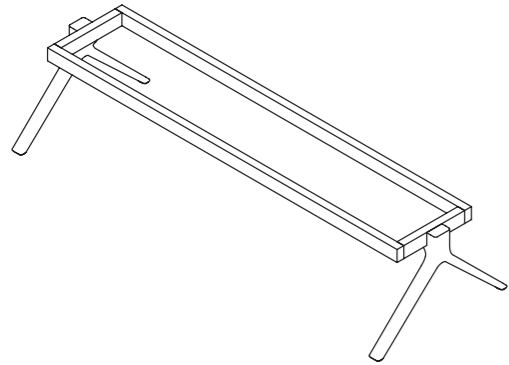

Art. 6301 – S189
 — Dimensions: 155,6x33x35 cm
 — Dimensions of complete item: 189x63 cm
 — Fills 3 units

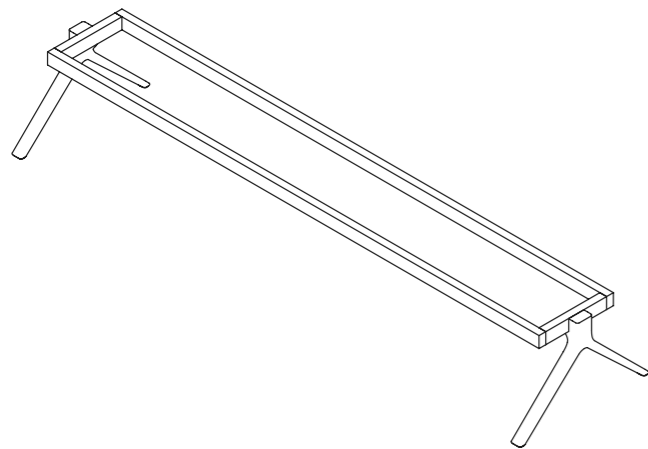

Art. 6300 – S252
 — Dimensions: 218,6x33x35 cm
 — Dimensions of complete item: 252x63 cm
 — Fills 4 units

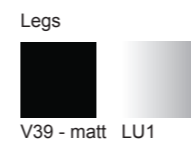
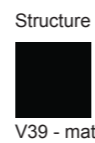

Seating modules

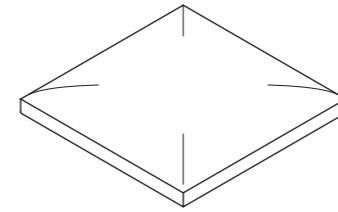

Art. 6303 – Cushion
 — Dimension: 63x63x10 cm
 — Fills 1 unit

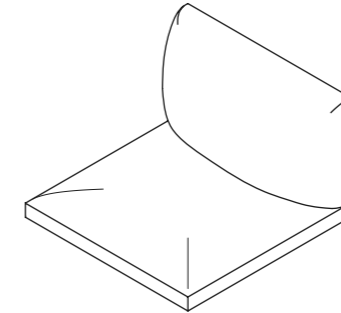

Art. 6304 – Cushion with standard backrest
 — Dimension: 63x63x40 cm
 — Fills 1 unit

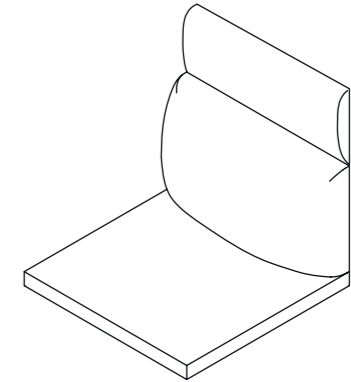

Art. 6332 – Cushion with high backrest
 — Dimension: 63x63x60 cm
 — Fills 1 unit

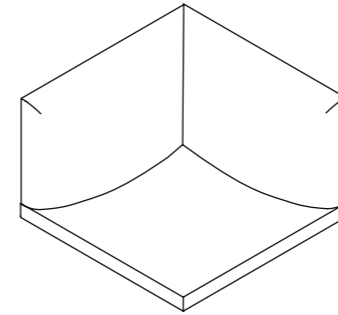

Art. 6328 / 6329 – Angular cushion with standard backrest
 — Dimension: 63x63x40 cm
 — Fills 1 unit

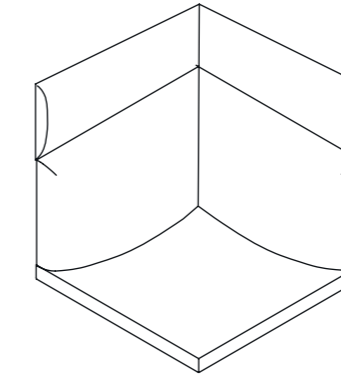

Art. 6330 / 6331 – Angular cushion with high backrest
 — Dimension: 63x63x60 cm
 — Fills 1 unit

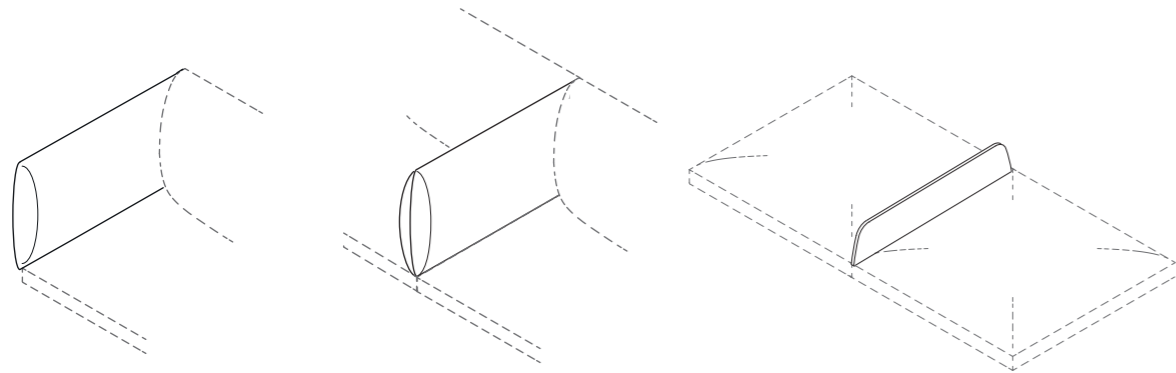

Art. 6334/6335 – Side armrest

Art. 6333 – Middle armrest

Art. 6336 – Separator between seats

Table modules

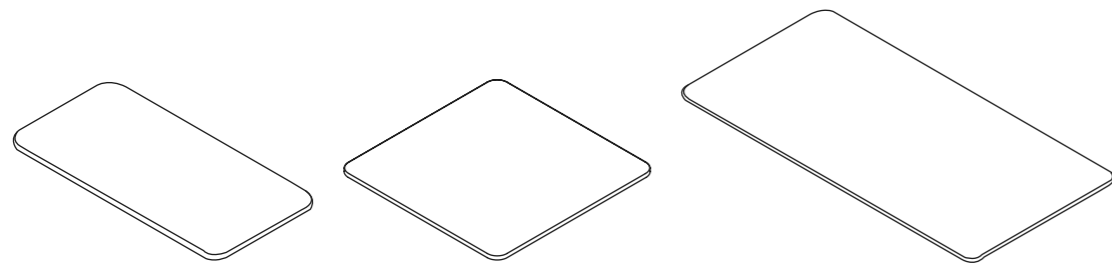

Art. 6310 – Rectangular side table
— Dimension: 31,5x63 cm
— Thick: 1,4 cm
— Fills 0,5 unit

Art. 6309 – Square side table
— Dimension: 63x63 cm
— Thick: 1,4 cm
— Fills 1 unit

Art. 6308 – Rectangular side table
— Dimension: 126x63 cm
— Thick: 1,4 cm
— Fills 2 units

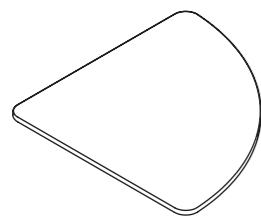

Art. 6311 – Quarter round side table
— Dimension: 63x63 cm
— Thick: 1,4 cm
— For compositions with 90° corner

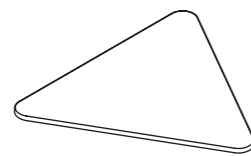

Art. 6312 – Triangular side table
— Dimension: 63x63x63 cm
— Thick: 1,4 cm
— For compositions with 120° corner

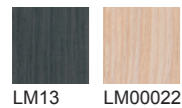

LM13

LM00022

Console

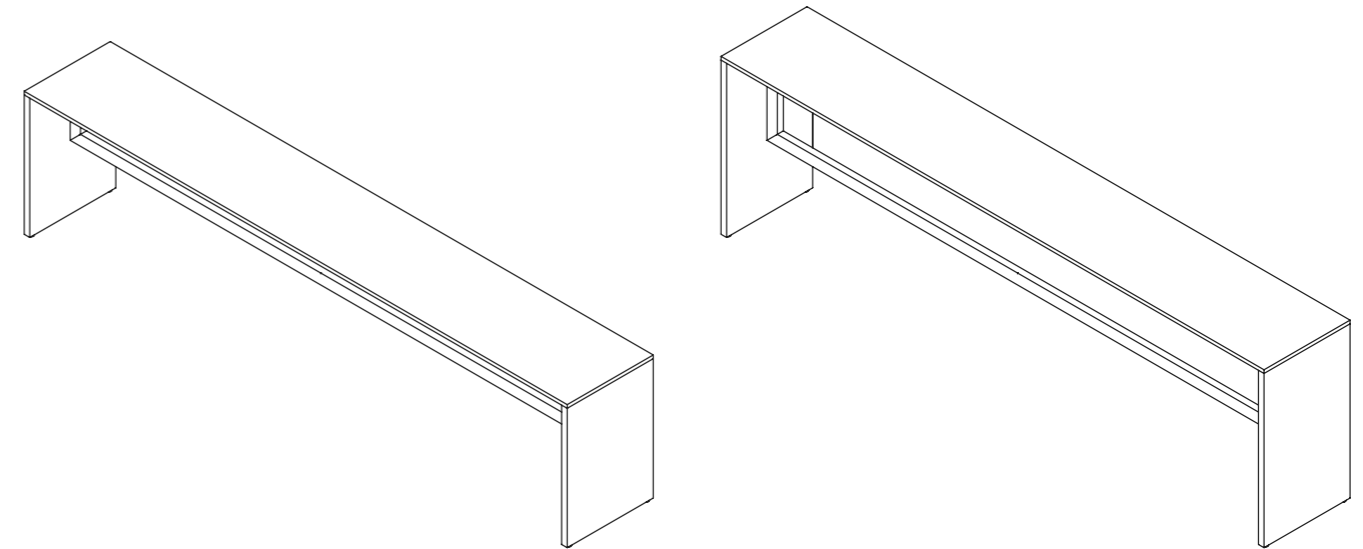

Art. 6305 – Console h 58 cm
— Dimensions: 252x40x58 cm

Art. 6306 – Console h. 72 cm
— Dimensions: 252x40x72 cm

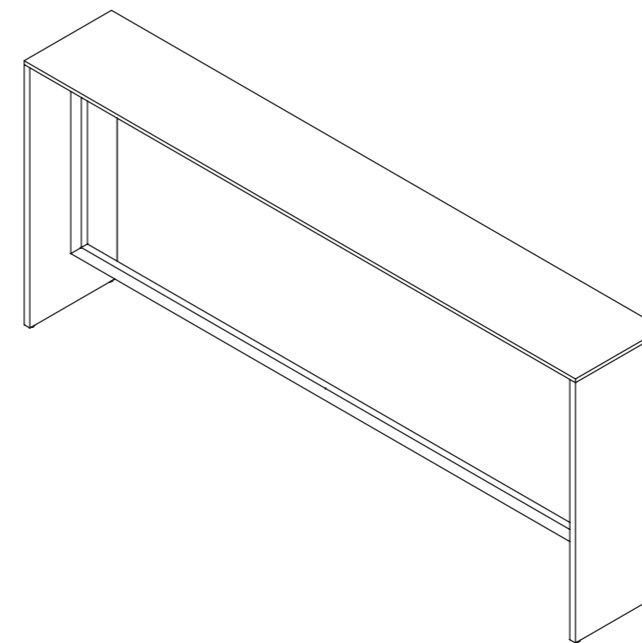

Art. 6307 – Console h. 105cm
— Dimensions: 252x40x105 cm

Ottoman

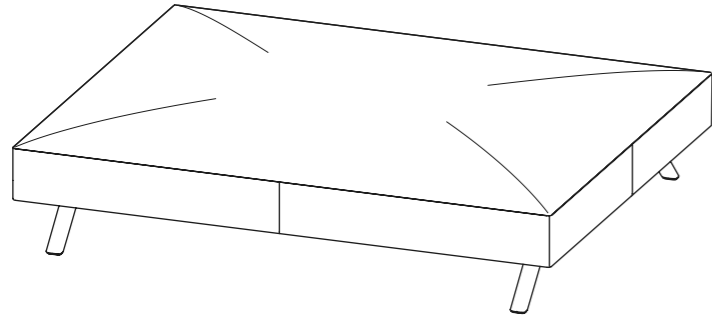

Art. 6313 – Ottoman
— Dimensions: 126x157,5x36 cm

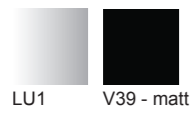

Link

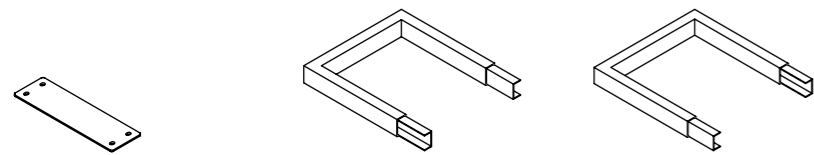

Art. 6316 – Plate-shaped link
— Dimensions: 26,6x8 cm

Art. 6314 – C-shaped link
— Dimensions: 31x33x5 cm

Art. 6315 – Island-shaped link
— Dimensions: 33,4x36x5 cm



Options



USB

Composition Examples



- 1 x Art. 6300 – Structure S252
- 3 x Art. 6304 – Cushion with backrest
- 4 x Art. 6310 – Rectangular table 31,5x63 cm
- 2 x Art. 6314 – C-shaped link

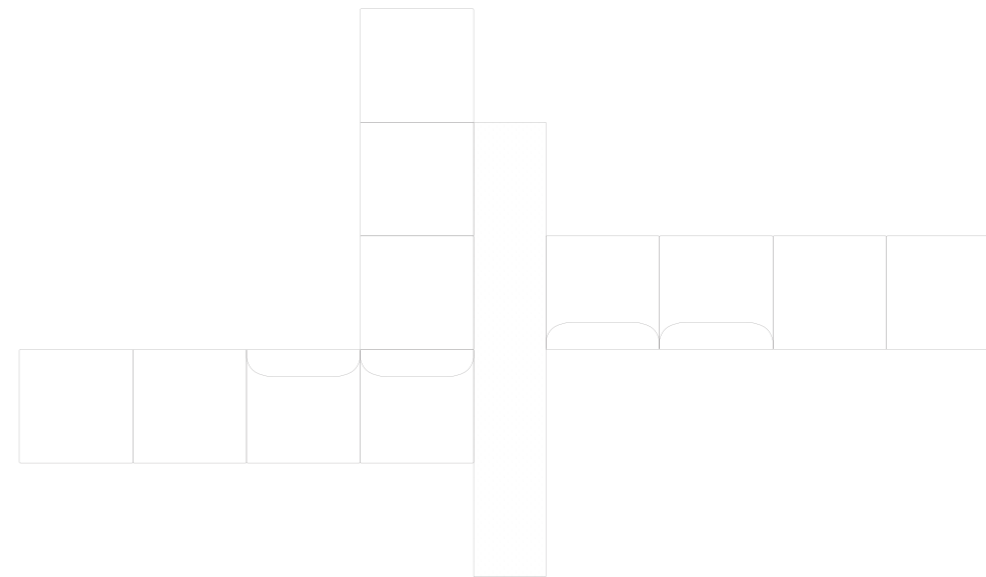

- 2 x Art. 6300 – Structure S252
- 1 x Art. 6301 – Structure S189
- 7 x Art. 6303 – Cushion
- 4 x Art. 6304 – Cushion with backrest
- 1 x Art. 6305 – Console h 58 cm
- 1 x Art. 6316 – Plate-shaped link



- 2 x Art. 6300 – Structure S252
- 8 x Art. 6304 – Cushion with backrest
- 1 x Art. 6306 – Console h 72 cm
- 1 x Art. 6300 – Structure S252
- 1 x Art. 6302 – Structure S126
- 4 x Art. 6304 – Cushion with backrest
- 1 x Art. 6310 – Rectangular table 126x63 cm
- 1 x Art. 6307 – Console h 105 cm
- 1 x Art. 6313 – Ottoman
- 1 x Art. 6316 – Plate-shaped link

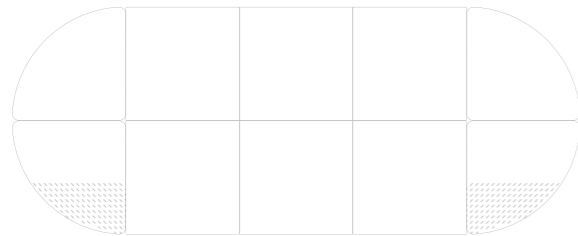

- 2 x Art. 6300 – Structure S252
- 6 x Art. 6303 – Cushion
- 4 x Art. 6311 – 1/4 circle table 63x63 cm
- 2 x Art. 6315 – Island-shaped link
- 2 x Art. 6316 – Plate-shaped link

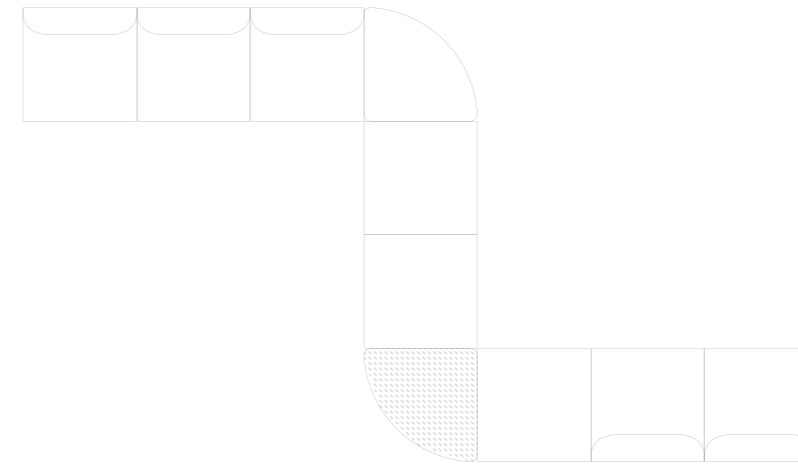

- 2 x Art. 6301 – Structure S189
- 1 x Art. 6302 – Structure S126
- 3 x Art. 6303 – Cushion
- 5 x Art. 6304 – Cushion with backrest
- 2 x Art. 6311 – 1/4 circle table 63x63 cm
- 4 x Art. 6314 – C-shaped link



- 1 x Art. 6300 – Structure S252
- 1 x Art. 6302 – Structure S126
- 4 x Art. 6303 – Cushion
- 2 x Art. 6304 – Cushion with backrest
- 1 x Art. 6312 – Triangular table 63x63x63 cm
- 3 x Art. 6316 – Plate-shaped link
- 1 x Art. 6305 – Console h 58 cm

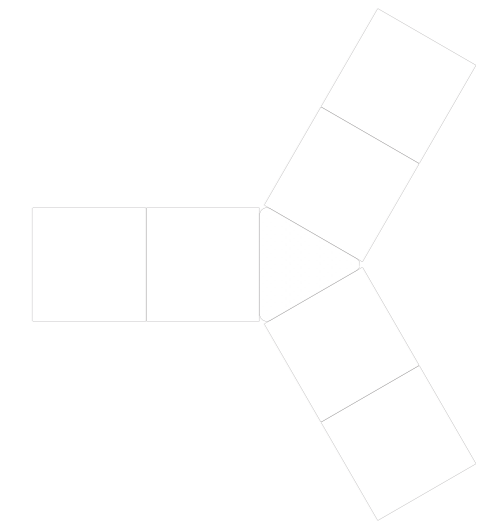

- 3 x Art. 6302 – Structure S126
- 6 x Art. 6303 – Cushion
- 1 x Art. 6312 – Triangular table 63x63x63 cm
- 3 x Art. 6316 – Plate-shaped link

Collection overview

Chair

Low backrest



Chair with a 5 way base mounted on castors with a polypropylene backrest, front face mesh and upholstered seat

Chair with a 5 way base mounted on castors, entirely upholstered seat and backrest

High backrest



Chair with a 5 way base mounted on castors with a polypropylene backrest, front face mesh and upholstered seat

Chair with a 5 way base mounted on castors, entirely upholstered seat and backrest

Stool

Low backrest



Stool with a 5 way base mounted on feet, polypropylene backrest, front face mesh and upholstered seat

Stool with a 5 way base mounted on feet, entirely upholstered seat and backrest



Stool with a 5 way base mounted on castors, polypropylene backrest, front face mesh and upholstered seat

Stool with a 5 way base mounted on castors, entirely upholstered seat and backrest

Armrest types



Width 10 cm



Width 14 cm

Mechanism

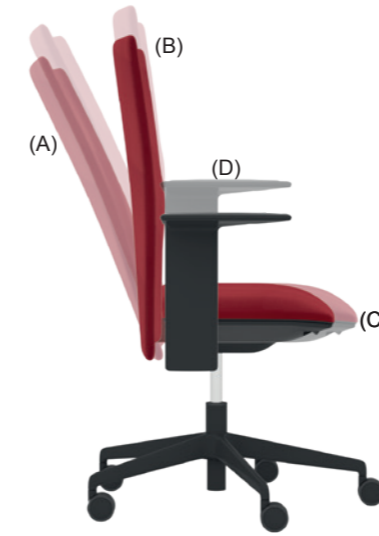

"Built-in self-tensioning weight response mechanism with:

- (A) backrest with 5-position recline
- (B) Up&down of the backrest with 5-position recline and built-in lumbar support.
- (C) Sliding seat with 5-position adjustment
- (D) Sliding armrests with 5-position adjustment"

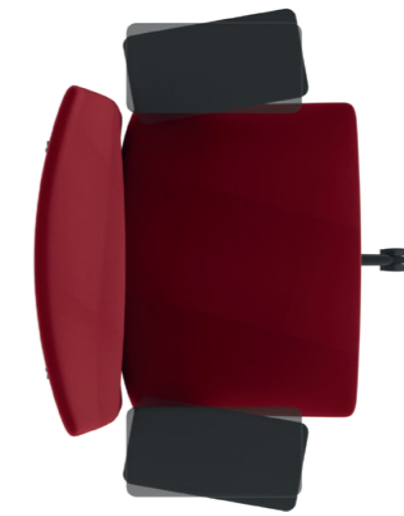

Armrest movement
It slides to the right and to the left

Instructions for modular arrangements

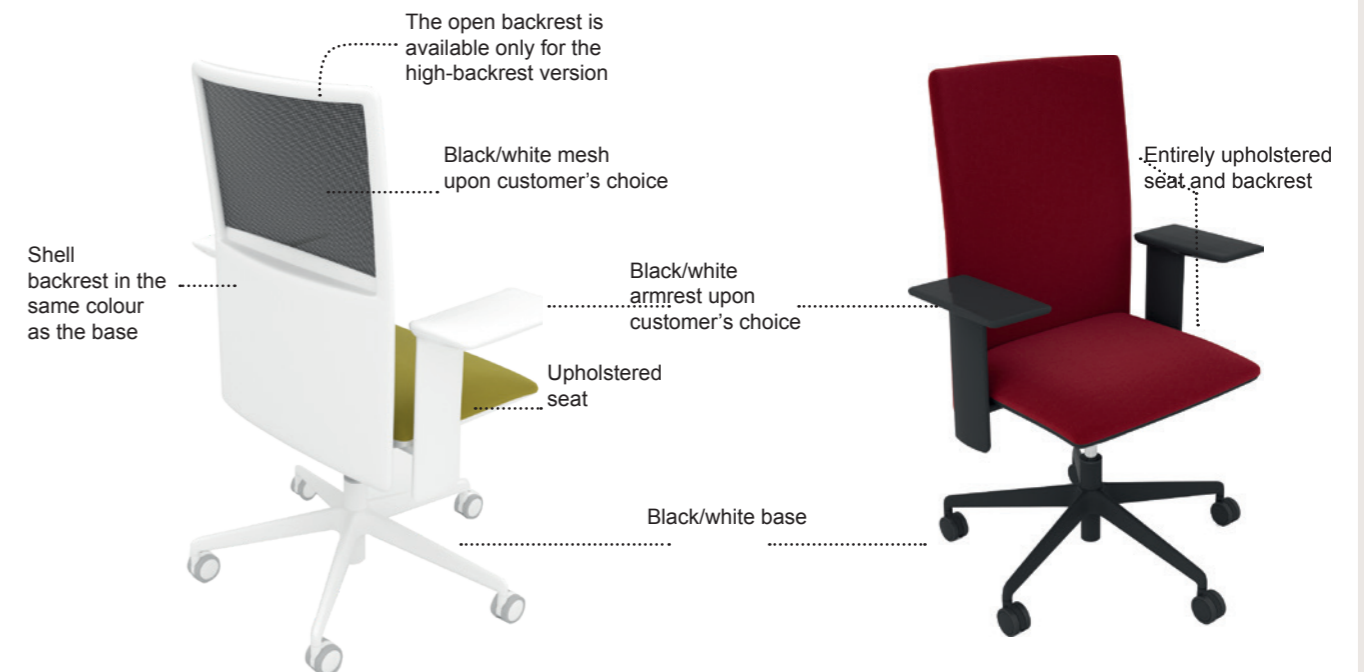

Collection overview

Type



Polypropylene chair mounted on castors

Polypropylene chair mounted on castors, with seat cushion

Polypropylene armchair mounted on castors

Polypropylene armchair mounted on castors, with seat cushion

Stool with castors

Shell

Chair version



Polypropylene

Polypropylene with seat cushion

Armchair version



Polypropylene

Polypropylene with seat cushion

Accessories



Writing tablet 50x33,5 cm

Movement on castors



All versions of Cila Go (chair, armchair, and stool) are mounted on castors to ease movement.

Type



Chair on a 5 way reinforced nylon fibre swivel base

Chair on a 5 way reinforced nylon fibre swivel base + writing tablet

Armchair on a 5 way reinforced nylon fibre swivel base

Armchair on a 5 way reinforced nylon fibre swivel base + writing tablet

Shell

Chair version



Polypropylene

Polypropylene with seat cushion

Upholstered with non-removable cover

Armchair version



Polypropylene

Polypropylene with seat cushion

Upholstered with non-removable cover

Collection overview

Bases



Sled base without armrests

Sled with armrests

Shells



Polypropylene seat and backrest

Upholstered seat and polypropylene backrest

Seat and backrest upholstered in one-colour

Options



Anti-panic writing tablet — only available for chromed sled

Row spacer

Chair linking system

Numbers for chairs and lines

Instructions for modular arrangements

Two-colour polypropylene versions Armrest layout



Polypropylene seat and backrest are available in a two colour version, with black seat and backrest in one of the other four colours available

Polypropylene seat and backrest: polypropylene armrests come in the same colour as the seat

Upholstered seat and polypropylene backrest: the polypropylene armrest pad comes in the same colour as the backrest

Upholstered seat and backrest: the polypropylene armrest pad is available in 5 colours

Stackability

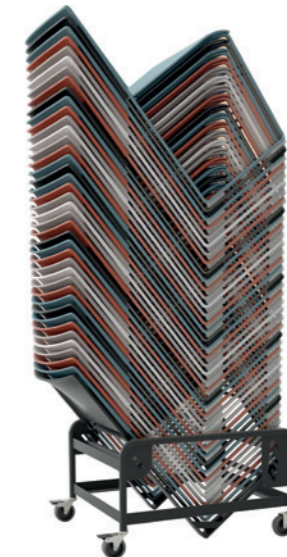

Glides color

Chromed bases: black glides.
Powdercoated bases: glides in the same color of the base

Upholstered versions: transparent stacking glides



Trolley for writing tablet



Trolley

Max 40 pcs
For the polypropylene version with no armrests
Max 25 pcs
For all other versions

Contacts

Italy

Monastier (TV) — Headquarters and showroom
Arper SPA
Via Lombardia 16
31050 Monastier di Treviso (TV)
T +39 0422 7918
F +39 0422 791800
info@arper.com
www.arper.com

Commerciale Italia
T +39 0422 791905
F +39 0422 791900
commerciale@arper.com

Export Office
sales@arper.com

Milan — Showroom
Via Pantano 30
20122 Milan
T +39 02 89093865
milano@arper.com

EUROPE

UK

London — Subsidiary and showroom
Arper UK LTD
11 Clerkenwell Road
London EC1M 5PA
T +44 (0) 20 7253 0009
london@arper.com

Belgium

Beernem — Branch and Meeting Hub
Sint-Jorisstraat 82,
8730 Beernem
T +32 50 705960
belgium@arper.com

Germany

Cologne — Showroom
Design Post Köln
Deutz-Mülheimer-Str. 22a
50679 Köln
T +49 221 690 650
info@designpost.de

Fruchtof München — Meeting Hub
2. Innenhof, 2. Etage
Gotzinger Straße 52b
D-81371 München
T +49 171 5548178
muenchen@arper.com

Norway

Oslo — Showroom
Drammensveien 130
0277 Oslo
T +47 908 202226
norway@arper.com

Sweden

Stockholm — Branch
T +46 705 101216
sweden@arper.com

The Netherlands

Amsterdam — Showroom
Design Post
Cruquiusweg 111-P
1019 AG Amsterdam
T +31 (0)20 705 1555
showroom@beltane.nl

AMERICA

USA

New York — Subsidiary and showroom
Arper USA Inc.
476 Broadway, Suite 2F
NY 10013 New York
T +1 (212) 647 8900
infousa@arper.com

Chicago — Showroom
The Merchandise Mart
Space#346 - 3rd Floor
Chicago
T +1 (336) 434 2366
infousa@arper.com

High Point, North Carolina — Production and logistics site
660 Southwest St
High Point, NC 27260
T +1 (336) 434 2370
F +1 (212) 647 8912
infousa@arper.com

Los Angeles — Showroom
550 South Hope St., Suite 275
90071 Los Angeles
T +1 (336) 434 2382
infousa@arper.com

Mexico

Mexico City — Subsidiary and showroom
Culiacan 123, Piso 9
Col. Hipodromo Condesa
Delegation Cuauhtémoc
06170 – Ciudad de México
Mexico
T +52 1 62714417
T +52 1 62714419
infolatam@arper.com

ASIA

Japan

Arper Japan K.K. — Subsidiary and showroom
HT Jingu Gaien Bldg.8F
Minato-ku Kita-Aoyama 2-7-22
Tokyo 107-0061
T +81 3 5775 0008
F +81 3 5775 0009
carejpn@arper.com

China

Shanghai — Subsidiary
爱尔派 (上海) 家具设计有限公司
Shanghai – China
china@arper.com

Singapore

Singapore — Branch
singapore@arper.com

UAE

Arper Middle East — Subsidiary and showroom
U-Bora Towers - Unit 1901
Business Bay
Dubai
T +971 509144800
infome@arper.com

arper

arper