

Arteco

OPERATIVO
OPERATIVE

BOOK
2018

Arteco
BOOK 2018

**OPERATIVO
OPERATIVE**

INDICE

INDEX / INDEX / INHALTSVERZEICHNIS / TABLA DE CONTENIDOS

LODGE

Pag. 14



NOISE REDUCTION

Pag. 36



LEVEL - UP

Pag. 56



KELIS

Pag. 72



H - TABLE

Pag. 84



GALAXY

Pag. 92



LED CL

Pag. 118



LED

Pag. 136



U FORM EVO

Pag. 172



A FORM EVO

Pag. 204



TAB

Pag. 228



TAVOLI RIUNIONE

Pag. 242



INDICE

INDEX / INDEX / INHALTSVERZEICHNIS / TABLA DE CONTENIDOS

ODD

Pag. 254



SLOT

Pag. 266



BANCONE RECEPTION

Pag. 274



CASSETTIERE

Pag. 284



TOMO SYSTEM

Pag. 286

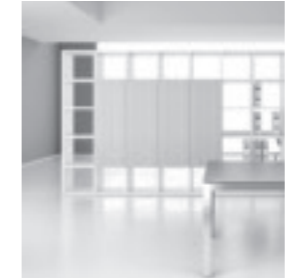

ARMADI

Pag. 300



SLIDE

Pag. 324



A-BOX

Pag. 338



CUB8

Pag. 344





COMPANY PROFILE

Dal 1985 nel mondo dell'arredamento per l'ufficio la ditta ARTECO si distingue per i suoi prodotti di qualità e funzionalità, per l'immediatezza dei servizi e per la disponibilità nella realizzazione dell'arredo. Arteco ha avuto in questi anni la capacità di prevedere le esigenze del mercato: ne deriva l'offerta di prodotti dal design innovativo con modullistica lineare e pratica che hanno portato all'affermazione e sviluppo dell'azienda. Scegliendo di rimanere di medie dimensioni ha potuto essere maggiormente duttile ed elastica e forte di questo ha sviluppato recentemente anche una produzione nelle varie tipologie di legno e cristallo, l'alluminio, la pelle, le laccature con la cura e l'attenzione artigianale che distingue il MADE IN ITALY. Sono così punti di forza i tavoli riunione, le scrivanie, i contenitori che si possono creare secondo le più svariate richieste. Il futuro dell'ARTECO sarà quindi il risultato del crogiolo della sua esperienza con il suo ostinato impegno nel proporre prodotti che segnano il tempo.

Depuis 1985 dans le monde du mobilier de bureau l'entreprise ARTECO se distingue par ses produits de qualité et de fonctionnalité, pour la promptitude des services et la disponibilité dans la réalisation de l'ameublement. ARTECO a eu en ces dernières années, la capacité d'anticiper les besoins du marché : il s'ensuit l'offre de produits avec une conception innovatrice avec formes linéaires et pratiques qui ont conduit au succès et au développement de la société. En choisissant de rester de taille moyenne, ARTECO pourrait être plus flexible et souple. Elle a récemment développé une production dans divers types de bois et de verre, aluminium, cuir et laqués avec le soin et l'attention artisanal qui distingue le "MADE IN ITALY". Donc les points forts sont les tables de réunion, les bureaux, les système de rangement que on peut créer selon les plupart des demandes diverses. L'avenir d'ARTECO est alors le résultat du "creuset" de son expérience avec son engagement tenace d'offrir des produits qui marquent le temps.

С 1985 года в мире мебели Итальянская компания Артеко выделяется своим качеством и функциональностью продукцией, непосредственностью услуг и доступностью на рынке офисной мебели. Артеко уделяет большое внимание высоким требованиям покупателей и следит за быстро меняющимся рынком офисной мебели. В последние годы была разработана продукция инновационного дизайна с линейными практическими формами, которая подняла компанию в лидирующие позиции. Предпочитая оставаться в средних и гибких масштабов, компания уделила большое внимания разработке производства из различных материалов как дерева, стекла, алюминия, кожи, лака, сохраняя традиции к работе с заботой и вниманием итальянских мастеров, чем и отличается знак качества Сделано в Италии. Не последнюю роль в успешном исходе деловой встречи играют переговорные столы и кабинеты руководителя, которые могут быть созданы в соответствии с самыми различными требованиями клиента. Будущее АРТЕКО это создание продукции соответственно требованиям времени используя многолетний опыт в производстве высококачественной продукции.

Since 1985 in the world of the office furnishing the firm ARTECO distinguishes itself for its quality and functionality products, for immediateness of services and availability in realization of furnishing. Arteco in these years has had the ability of expect the requirements of the market: from this come the offer of products of innovative design with linear and practical set of forms that has led the firm towards achievement and development. Choosing a flexible, the company has been able to interpret the request market by developing products of wood and glass -aluminum and steel -with leather and lacquered finishes that represent the care and attention of the typical craft product MADE IN ITALY So meeting tables, desks and cabinet are point of force because they can be created according to the most various requests. ARTECO's future is going to be the result of the melting pot of its experience with its persistent pledge of proposing products that mark the time.



Arteco's mission is to enhance its customers' productivity by creating and producing attractive and functional work environments. In Arteco we create work environments designed for man and his wellbeing, combining instruments such as technological research, Italian design and craft expertise with an industrial productive capacity of low environmental impact. We are aware of being promoters of an evolutionary process involving men and women, increasing their competence in the solution of problems on the basis of real experience, by living daily among the environments we have designed and created.

MISSION

La mission di Arteco è di aumentare la produttività dei suoi clienti progettando e realizzando ambienti di lavoro funzionali e dal design essenziale, facendo leva sulle capacità, i punti di forza e le risorse uniche della nostra diversità.

Creiamo spazi adatti a Voi e al Vostro benessere, combinando insieme al design Italiano, anche la ricerca tecnologica, la professionalità, la competenza e un'industria produttiva a basso impatto ambientale. Vogliamo essere i promotori di un processo evolutivo coinvolgendo uomini e donne, aumentando le loro competenze nella risoluzione dei problemi sulla base delle reali esperienze e vivendo giorno per giorno l'ambiente e gli spazi che abbiamo ideato e costruito.

La mission d'ARTECO est d'augmenter la productivité de ses clients en concevant et en créant des milieux de travail fonctionnel et avec un design essentiel, s'appuyant sur les capacités, les forces et les ressources uniques de notre diversité.

Nous créons des espaces en fonction de vous et votre bien-être, en alliant le design italien, la recherche technologique, le professionnalisme, la compétence et une usine productive à faible impact environnemental. Nous voulons être les promoteurs d'un processus évolutif, impliquant des hommes et des femmes, améliorer leurs compétences en résolution de problèmes sur la base d'expériences réelles, et vivent au jour le jour, l'environnement et les espaces que nous avons conçu et construit.

Миссия Артеко является повышение удовлетворённости своих клиентов, опираясь на взаимодействия своих сотрудников и созданием благоприятной рабочей атмосферы. Мы создаем условия для Вас и Вашего благополучия, сочетая итальянский дизайн, технологические исследования, профессионализм, опыт и производства с низким воздействием на окружающую среду. Мы хотим способствовать эволюционному процессу потребительского рынка с участием наших сотрудников, повышая их навыки в решениям проблем на основе реального опыта жизни офисной среды и пространства, разрабатывая практическую, удобную и многофункциональную мебель.



PRODUCTION

Arteco combina l'alta qualità dei materiali con un'efficiente organizzazione produttiva. Adotta un sistema di produzione just-in-time e coordina un gruppo di fornitori, permettendo così soluzioni rapide in funzione alle più svariate richieste del cliente. Grazie al suo competitivo Set-Up, l'azienda è in grado di gestire numerose collezioni in una grande varietà di dimensioni e finiture. Arteco si prende cura dei suoi clienti offrendo un'efficiente servizio di assistenza.

ARTECO allie des matériaux de haute qualité avec une organisation productive très efficace. Elle adopte un système de production just-in-time et coordonne un groupe de fournisseurs, permettant ainsi solutions rapides selon les exigences des clients. Grâce à son set-up concurrentiel, l'entreprise est capable de gérer de nombreuses collections dans une variété de tailles et finitions. ARTECO se prend soin de ses clients en offrant un service d'assistance efficace

Arteco combines high-quality materials with efficient production organization. The company adopts a just-in-time production system and coordinates a group of suppliers, enabling it to provide quick solutions to customer requests, including the most varied.

Thanks to this highly competitive set-up, Arteco is able to handle numerous collections in a variety of sizes and finishes. Besides offering quick production times, high-quality packaging is essential to guarantee impeccable products for end consumers. Arteco assists its customers by supplying a highly professional design consultation service free of charge.

Артеко нашел способ сочетания закупки высококачественных материалов и организацией производством эффективным методом Just-in-time. Работая этим методом Артеко сотрудничает с группой поставщиков, что позволяет принимать быстрые решения с соответствии с различными требованиями заказчика. Благодаря своей лидирующей позиции на рынке, компания имеет возможность создавать многочисленные коллекции в различных размеров и отделок. Артеко заботится о своих клиентах, предоставляя обслуживание каждому клиенту индивидуально.



ARTECO has always focused its efforts on developing ecologically friendly products and activities while maintaining a high level of customer satisfaction. We believe that a sustainable business can work for the environment, the consumer and the employee. Nowadays the consumer is increasingly aware of the importance of preserving our natural heritage and is increasingly willing to take an active role in protecting the environment.



ENVIRONMENT

ARTECO ha sempre concentrato i suoi sforzi nello sviluppo di prodotti e attività rispettosi dell'ambiente, mantenendo un alto livello di soddisfazione del cliente. Crediamo che uno sviluppo sostenibile sia positivo oltre che per l'ambiente anche per i consumatori e i dipendenti. Oggi i consumatori stanno aumentando la loro consapevolezza nell'importanza di preservare il nostro patrimonio naturale, e per questa ragione si curano di accrescere la loro partecipazione nelle attività di protezione dell'ambiente.

ARTECO a toujours concentré ses efforts dans le développement de produits et d'activités respectueuses de l'environnement, maintenant un niveau élevé de satisfaction de la clientèle. Nous croyons que le développement durable est positif ainsi que de l'environnement pour les consommateurs et les employés. Aujourd'hui les consommateurs augmentent leur prise de conscience sur l'importance de la préservation de notre patrimoine naturel et pour cette raison ils se soignent d'accroître leur participation aux activités de protection de l'environnement.

За всю свою деятельность Артеко сосредоточил свои усилия на разработке экологически чистых продуктов и видов деятельности, сохраняя при этом высокий уровень удовлетворенности клиентов. Мы считаем, что устойчивый бизнес может работать на окружающую среду, на потребителя и работника. В настоящее время потребители все больше осознают важность сохранения нашего природного наследия и чаще готовы принять активное участие в защите окружающей среды.

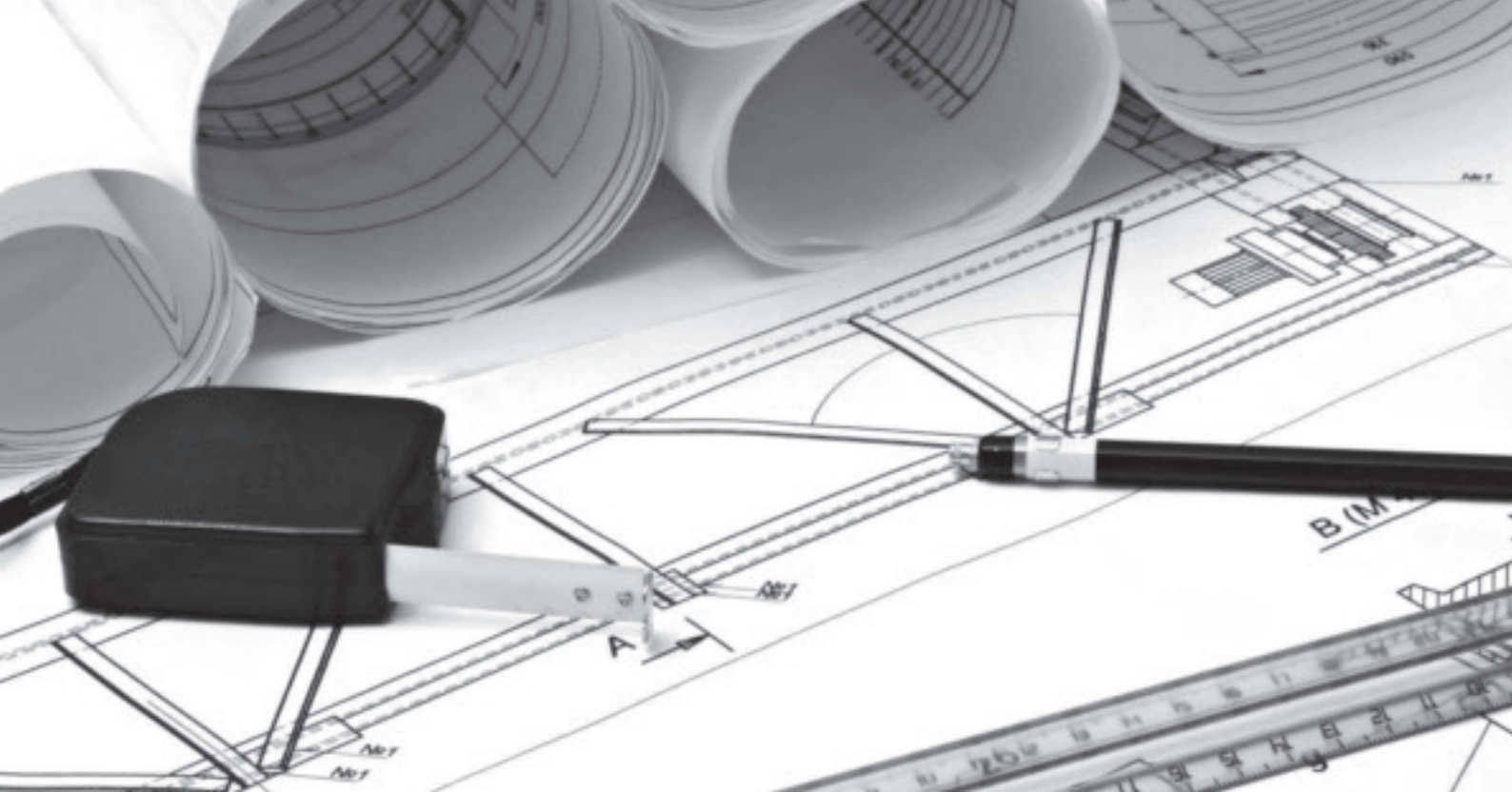

La caratteristica che contraddistingue ARTECO è la personalizzazione degli articoli secondo le esigenze del cliente. Questo è stato reso possibile grazie alla continua rimodernizzazione del design, e dalle nuove tecnologie e materiali che si rendono facilmente adattabili a ciascuna richiesta.

La caractéristique qui distingue ARTECO est la personnalisation des éléments selon les exigences du client. Ceci a été rendu possible grâce à la continue re-modernisation du Design, aux nouvelles technologies et aux matériaux qui sont facilement applicables à chaque demande.

The distinguishing feature of ARTECO is that it has always supplied genuinely customized products with original layouts and a refined selection of available finishes. This goal is achieved thanks to continuously updated design, technologies and materials for the most versatile solutions, which can be easily adapted and altered as required.

Сильной чертой Артеко является персонализация изделия в соответствии с требованиями заказчика. Это стало возможным благодаря постоянной модернизации дизайна, новых технологии и материалов, которые делают его легко адаптируемой к каждому запросу.

CUSTOMIZED
DESIGN



ARTICOLI IN CLASSE 1 IGNIFUGO Arteco

FIREPROOF ITEMS CLASS 1 - PRODUITS AVEC CLASSE 1 IGNIFUGÉ
FEUERFEST ARTIKEL KLASSE 1 - PRODUCTOS DE CLASE 1
IGNÍFUGO



ARMADI - CABINETS - ARMOIRE - SCHRANK - ARMARIO

SCOCCA, FRONTALI ED ANTE IN MELAMINICO NOBILITATO
STRUCTURE, DOORS AND FRONTS MELAMINE / STRUCTURE, FACADES ET PORTES EN MELAMINE
MELAMIN E1 KORPUS, FRONTEN UND TÜREN / ESTRUCTURA, FRONTALES Y PUERTAS MELAMINICO
SP 18 MM / TH 18 MM / EP 18 MM / D 18 MM / ES 18 MM

 BI	BIANCO IGNIFUGO/ WHITE FIREPROOF / BLANC IGNIFUGÉ / WEISS FEUERFEST / BLANCO IGNÍFUGO
 NI	NERO IGNIFUGO/ BLACK FIREPROOF / NOIR IGNIFUGÉ / SCHWARZ FEUERFEST / NEGRO IGNÍFUGO

SCRIVANIE - DESK - BUREAU - SCHREIBTISCH - ESCRITORIO

PIANO IN MELAMINICO NOBILITATO
TOP MELAMINE / PLATEAU EN MELAMINE
PLATTEN MELAMIN / PLANES MELAMINICO
SP 18/25 MM / TH 18/25 MM / EP 18/25 MM / D 18/25 MM / ES 18/25 MM

 BI	BIANCO IGNIFUGO/ WHITE FIREPROOF / BLANC IGNIFUGÉ / WEISS FEUERFEST / BLANCO IGNÍFUGO
 NI	NERO IGNIFUGO/ BLACK FIREPROOF / NOIR IGNIFUGÉ / SCHWARZ FEUERFEST / NEGRO IGNÍFUGO

DISPONIBILE SU RICHIESTA
AVAILABLE ON REQUEST / DISPONIBLE SUR
DEMANDE
AUF ANFRAGE LIEFERBAR / DISPONIBLE A PETICIÓN

Non ci sono quantitativi minimi per la produzione
There are no minimum quantities for production - Il n'y a pas des quantités minimales pour la production
Es gibt keine Mindestmengen für die Produktion - No haya cantidades mínimas de producción

RECEPTION PROGRAM IS MADE UP FROM ELEMENTS WITH GLASS AND LED LIGHTS WHICH ALLOW DIFFERENT CONFIGURATIONS OF FURNITURE IN ACCORDANCE WITH THE REQUIREMENTS OF SPACE. THE QUALITY, ACCURACY AND FINISHING MATERIALS, SATISFY ALL REQUIREMENTS OF THE OPERATORS.

IL PROGRAMMA RECEPTION FORMATO DA ELEMENTI CON VETRO E LUCI LED PERMETTE DIFFERENTI CONFIGURAZIONI D'ARREDO A SECONDA DELLE ESIGENZE DI SPAZIALITA'. LA QUALITA', L'ACCURATEZZA E LE FINITURE DEI MATERIALI IMPIEGATI, SODDISFANO TUTTE LE ESIGENZE DEGLI OPERATORI.





I riflessi del cristallo, uniti alla corposità della luce a led, creano atmosfere suggestive nell'area di accoglienza.

Reflections of glass, combined with fullness of led light, create suggestive atmospheres in the reception area.







L'unione degli elementi a 45° esalta linee minimaliste e autentiche evidenziando l'emozione dei materiali.

45° joint elements enhances minimalist and authentic lines, highlighting the emotion of materials.





La completezza nella configurazione dei vari elementi, permette di creare soluzioni ad hoc per ogni esigenza di accoglienza.

Entirity's configuration of various elements allows customized creations of solutions for every kind of hospitality.





La divisione degli spazi di lavoro permette maggior privacy all'interno dell'area reception.

Division of work space allows greater privacy in the reception area.

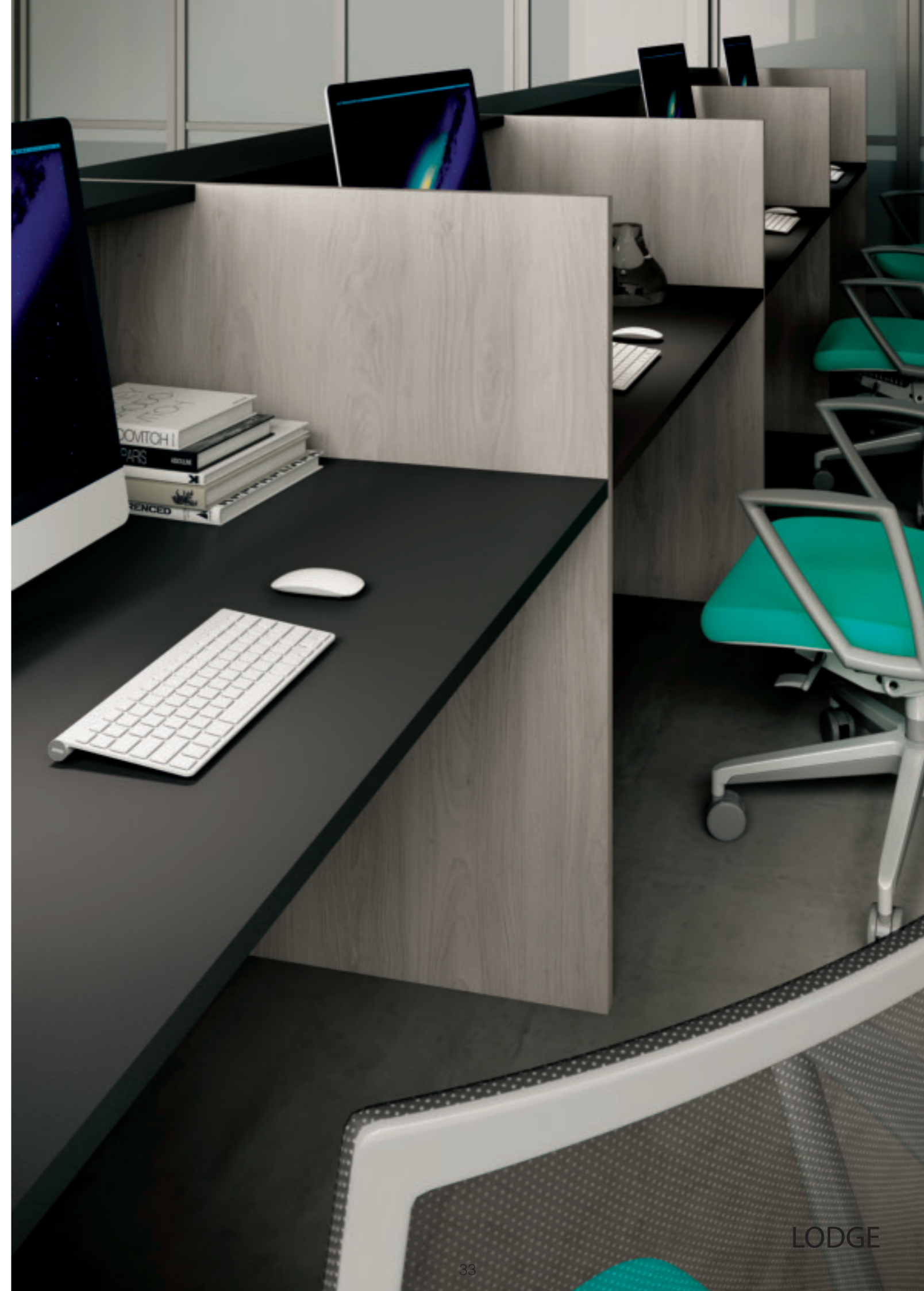

FINITURA NOBILITATO
FINISHING MELAMINE M



CRISTALLO
GLASS / VERRE / KRISTALLGLAS / CRISTAL

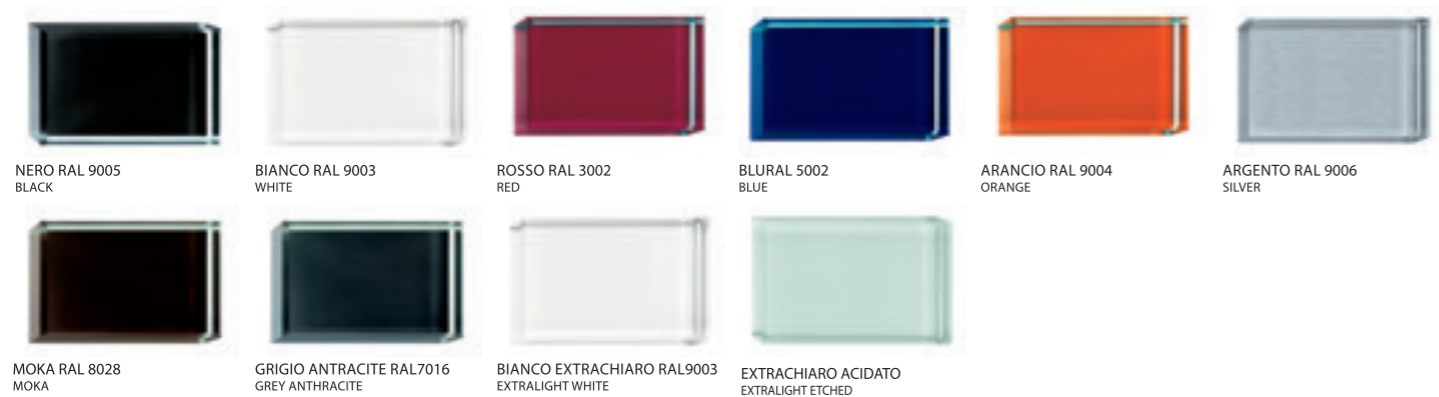

Frontale bancone lineare
Straight front module / Façade linéaire
Einzelwand freistehend / Pared simple independiente



100	30	113
120	30	113
140	30	113
160	30	113
180	30	113



100	30	113
120	30	113
140	30	113
160	30	113
180	30	113

Frontale bancone lato dx/frontale 1 lato a 45°
Right/front module with 1 side 45° / Façade droite/frontal avec 1 coté 45°
Einzelwand freistehend / Pared simple independiente



113,2	30	113
133,2	30	113
153,2	30	113
173,2	30	113
193,2	30	113



113,2	30	113
133,2	30	113
153,2	30	113
173,2	30	113
193,2	30	113

Frontale bancone lato sx/frontale 1 lato a 45°
Left/front module with 1 side 45° / Façade gauche/frontal avec 1 coté 45°
Einzelwand freistehend / Pared simple independiente



113,2	30	113
133,2	30	113
153,2	30	113
173,2	30	113
193,2	30	113



113,2	30	113
133,2	30	113
153,2	30	113
173,2	30	113
193,2	30	113

Piano per bancone zona disabili
Desk top for disabled / Plateau pour PMR
Einzelwand freistehend / Pared simple independiente

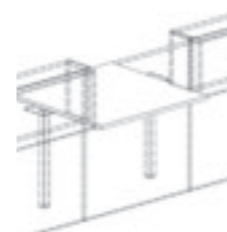

100	100	2,5
120	100	2,5

NOISE REDUCTION

IL PROGRAMMA NOISE REDUCTION PERMETTE LA DIVISIONE DEGLI SPAZI DI LAVORO CON ELEMENTI FONOASSORBENTI CHE NE ESALTANO LE QUALITÀ TECNICHE ED ESTETICHE.

NOISE REDUCTION PROGRAM ALLOWS DIVISION OF WORK SPACES WITH SOUND-ABSORBING ELEMENTS, WHICH ENHANCE THEIR TECHNICAL AND AESTHETIC QUALITIES.









PARETE NOISE REDUCTION

Telaio / Frame:
alluminio verniciato / painted aluminum

Tessuto / Fabric:
ignifugo / fire proof
sfoderabile / removable
lavabile / washable

Pannello isolante / Noise-absorbing partition:
anallergico / anallergic
ecologico / ecological
riciclabile / recyclable

Fire proof

- UNI EN 1350-1 B52 do
- UNI 9177 Classe 1

Fabric Mirage by PugIRG

Composition 100% Polyester FR - (Tr Cs)

Weight gr./mtl. 460 ± 10%

Abrasion (Martindale) UNI EN ISO 12497:2000 100.000 turns ± 20%

Fire proof

- Italia - Classe 1
- Germania - B1 DIN 4102
- Francia - M1
- Austria - B1 OENORM B3825 - Q1 OENORM 3800 Part. 1
- BS 5852 Crib 5 using a CM Foam 35 kg/cu.m
- EN 1021 Part.1-2 using a CM Foam 35 kg/cu.m
- USA Calif. Bull. 117 June 2013
- EN 13501 - 1^{1,2} : B-s1, d0
- EN 13773 Burning Behaviour: class 1
- EN ISO 6940/6941
- Svizzera - Fire Protection Classification: 5.3
- Francia - NF D 60-013:2006 AM18

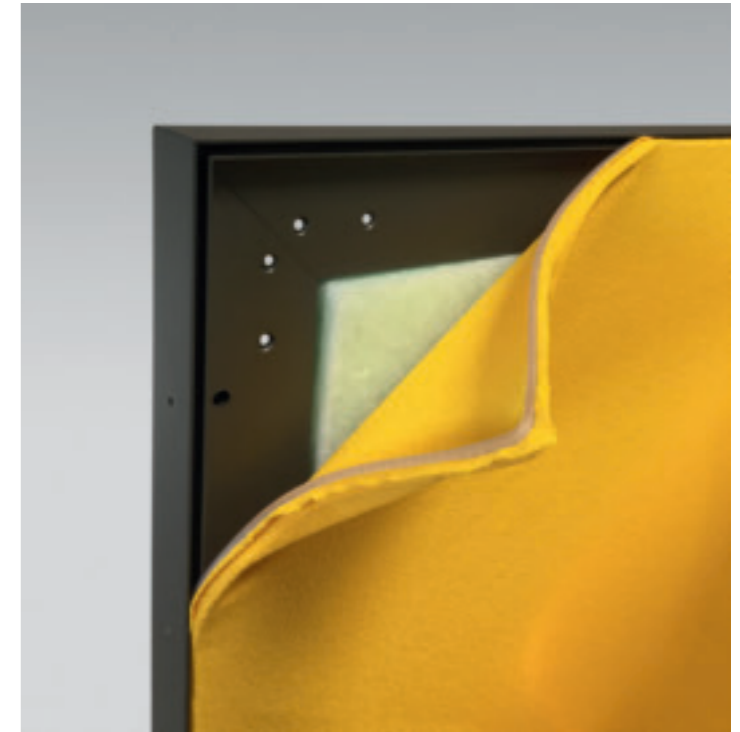

Pannello isolante

Pannelli in fibra poliestere ecologico, ricavati dal riciclo di plastiche PET e a loro volta riciclabili dopo l'utilizzo, esenti da qualsiasi sostanza allergica o dannosa alla salute, inattaccabili da muffe, umidità, roditori ed insetti, e privi di qualsiasi sostanza e trattamento chimico e privo di resine e/o collanti in genere

Noise-absorbing partition

Noise-absorbing panel made of ecological polyester coming from recycling of pet plastics recyclable in turn after use, free of any kind of allergic or health-dangerous substance, mood/humidity-proof and rodents/insects-proof free of any kind of substance or chemical treatment, resin and glue.

Internal material

Polyester fiber thickness 40 mm density 40 kg/m³

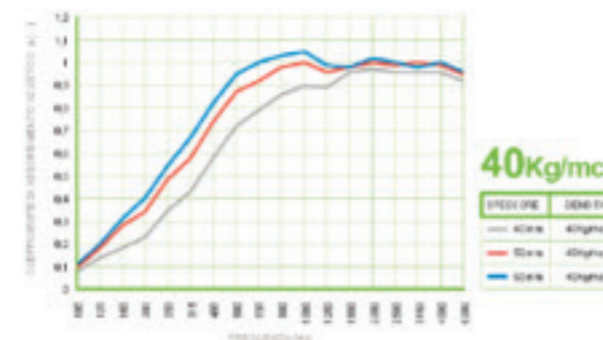



NOISE REDUCTION





NOISE REDUCTION







STRUTTURA ALLUMINIO

STRUCTURE ALUMINIUM / STRUCTURE ALUMINIUM / STRUKTUR ELOXIERT / ESTRUCTURA ALUMINIO



VERNICIATO NERO RAL 9005
PAINTED BLACK

VERNICIATO BIANCO RAL 9003
PAINTED WHITE

GRIGIO ALLUMINIO RAL9006
GREY ALUMINIUM

TESSUTO

FABRIC / ECRAN/ BILDSCHIRM/ PANTALLA



629 GRIGIO
GREY / GRIS / GRAU / GRIS

625 GRIGIO SCURO
GREY / GRIS / GRAU / GRIS

651 NERO
BLACK / NOIR / SCHWARZ / NEGRO

386 BLU
BLUE / BLEU / BLAU / AZUL

378 AVIO / BLUE AVIO
BLEU AVIO / BLAU AVIO / AZUL AVIO

425 VERDE
GREEN / VERTE / GRUN / VERDE

53 GIALLO
YELLOW / JAUNE / GELB / AMARILLO

120 ARANCIO / ORANGE
ORANGE / ORANGE / ANARANJADO

236 ROSSO
RED / ROUGE / ROT / ROJO

175 PRUGNA
PLUM / PRUNE / PFLAUME / CIRUELA

532 BEIGE
BEIGE / BEIGE / BEIGE / BEIGE

534 MARRONE
BROWN / MARRON / BRAUN / MARRON

PIANO SCRIVANIA NOBILITATO M1

DESK TOP MELAMINE M1



BIANCO
WHITE

GRIGIO
GREY

PIANO SCRIVANIA NOBILITATO M2

DESK TOP MELAMINE M2



NOCE CANALETTO
CANALETTO WALNUT

ROVERE
OAK



L	SP	H	L	SP	H
60	3,5	120	60	3,5	160
70	3,5	120	70	3,5	160
80	3,5	120	80	3,5	160
90	3,5	120	90	3,5	160
100	3,5	120	100	3,5	160

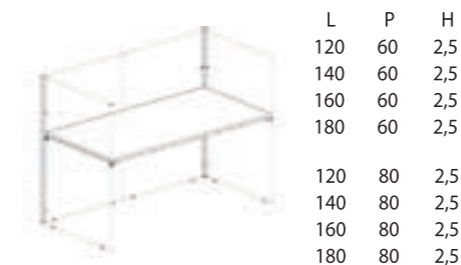

L	P	H
120	60	2,5
140	60	2,5
160	60	2,5
180	60	2,5
120	80	2,5
140	80	2,5
160	80	2,5
180	80	2,5



L	P	H
140	70	2,5
160	70	2,5

NOISE REDUCTION

TAVOLI ELEVABILI ELETTRICAMENTE PER UNA NUOVA
INTERPRETAZIONE ERGONOMICA DELL' AMBIENTE E DEL
SISTEMA DI LAVORO.

ELECTRICALLY ELEVATING DESKS FOR A NEW ERGONOMIC
INTERPRETATION OF ENVIROMENT OF WORK SYSTEM.















CANALIZZAZIONE CENTRALE CON COPERCHIO ASPORTABILE, PREDISPOSTA CON FORI PER PASSAGGIO CAVI E FISSAGGIO VERTEBRE.

CENTRAL PASSAGE CABLE WITH REMOVABLE LID, WITH HOLES FOR CABLE UP ROUTING.



PANNELLI REMOVIBILI PER PASSAGGIO CAVI

REMOVABLE PANELS FOR WIRING SYSTEM

STRUTTURA ALLUMINIO

STRUCTURE ALUMINIUM / STRUCTURE ALUMINIUM / STRUKTUR ELOXIERT / ESTRUCTURA ALUMINIO



VERNICIATO NERO RAL 9005
PAINTED BLACK

VERNICIATO BIANCO RAL 9003
PAINTED WHITE

GRIGIO ALLUMINIO RAL9006
GREY ALUMINIUM

PIANO SCRIVANIA NOBILITATO M1

DESK TOP MELAMINE M1



BIANCO
WHITE

GRIGIO
GREY

PIANO SCRIVANIA NOBILITATO M2

DESK TOP MELAMINE M2



ROVERE GRIGIO
GREY OAK

NOCE SBIANCATO
BLEACHED WALNUT

NOCE CANALETTO
CANALETTO WALNUT

ROVERE
OAK

NERO
BLACK

TESSUTO

FABRIC / ECRAN/ BILDSCHIRM/ PANTALLA



629 GRIGIO
GREY / GRIS / GRAU / GRIS

625 GRIGIO SCURO
GREY / GRIS / GRAU / GRIS

651 NERO
BLACK / NOIR / SCHWARZ / NEGRO

386 BLU
BLUE / BLEU / BLAU / AZUL

378 AVIO / BLUE AVIO
BLEU AVIO / BLAU AVIO / AZUL AVIO

425 VERDE
GREEN / VERTE / GRUN / VERDE

53 GIALLO
YELLOW / JAUNE / GELB / AMARILLO

120 ARANCIO / ORANGE
ORANGE / ORANGE / ANARANJADO

236 ROSSO
RED / ROUGE / ROT / ROJO

175 PRUGNA
PLUM / PRUNE / PFLAUME / CIRUELA

532 BEIGE
BEIGE / BEIGE / BEIGE / BEIGE

534 MARRONE
BROWN / MARRON / BRAUN / MARRON

GRAFICI

GRAPHS / GRAPHIQUES / GRAPHS / GRAFICOS



120 70 65/125 120 80 65/125 120 90 65/125
140 70 65/125 140 80 65/125 140 90 65/125
160 70 65/125 160 80 65/125 160 90 65/125
180 70 65/125 180 80 65/125 180 90 65/125
200 70 65/125 200 80 65/125 200 90 65/125



120 170 65/125
140 170 65/125
160 170 65/125
180 170 65/125
200 170 65/125

FENIX NTM®

Riparabilità termica dei micrograffi superficiali
Thermal healing of superficial microscratches
Réparation thermique des micro-rayures superficielles
Thermische Bearbeitung von oberflächlichen Kratzern
Reparabilidad térmica de microarañazos superficiales

Morbidezza al tatto
Soft touch
Toucher soyeux
Weicher Touch
Suave al tacto

Resistenza al calore secco
Resistance to dry eat
Résistance à la chaleur sèche
Resistent gegen trockene Hitze
Resistencia al calor seco

Bassa riflessione della luce, superficie estremamente opaca
Low light reflectivity, extremely matt surface
Faible réflectivité, surface extrêmement mate
Geringe Lichtreflexion, extrem matte Oberfläche
Reflectancia mínima de la luz, superficie extremadamente mate

Anti-impronta
Anti-fingerprint
Aucune trace de doigts
Keine Fingerabdrücke
Anti-huella digital

Resistenza ai graffi e all'abrasione
Resistance to scratches and abrasion
Résistance aux rayures et à l'abrasion
Resisten gegen Kratzer und Abrieb
Resistencia a los arañazos y a la abrasion

Alta attività di abbattimento della carica batterica
Enhanced anti-bacterial properties
Propriétés antibactériennes renforcées
Verbesserte antibakterielle Eigenschaften
Propiedad anti-bacterias reforzada



BIANCO KOS 0032
WHITE KOS 0032 / BLANC KOS 0032
WEISS KOS 0032/ BLANCO KOS 0032



NERO INGO 0720
BLACK INGO 0720/ NOIR INGO 0720
SCHWARZ INGO 0720/ NEGRO INGO 0720



GRIGIO LONDRA 0718
GREY LONDRA 0718/ GRIS LONDRA 0718
GRAU LONDRA 0718 / GRIS LONDRA 0718

TAVOLI MULTIFUNZIONALI DOTATI DI PIANO RIBALTABILE
FACILMENTE MANOVRABILI.

MULTIFUNCTIONAL TABLES EQUIPPED OF FOLDING TABLE
EASLY MANOEUVRABLE.











STRUTTURA METALLO

METAL FRAME / STRUCTURE METAL / METAL STRUKTUR / ESTRUCTURA METAL



VERNICIATO BIANCO RAL 9003
PAINTED WHITE



GRIGIO ALLUMINIO RAL9006
GREY ALUMINIUM

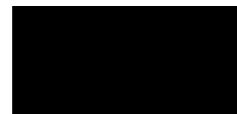

VERNICIATO NERO RAL 9005
PAINTED BLACK

PIANO SCRIVANIA NOBILITATO M1

DESK TOP MELAMINE M1



BIANCO
WHITE



GRIGIO
GREY

PIANO SCRIVANIA NOBILITATO M2

DESKTOP MELAMINE M2

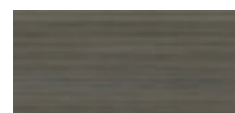

ROVERE GRIGIO
GREY OAK



NOCE SBIANCATO
BLEACHED WALNUT

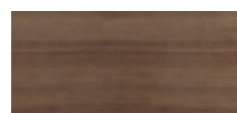

NOCE CANALETTO
CANALETTO WALNUT



ROVERE
OAK



NERO
BLACK

GRAFICI

GRAPHS / GRAPHIQUES / GRAPHS / GRAFICOS



L	P	H	L	P	H	L	P	H
120	60	74	120	70	74	120	80	74
140	60	74	140	70	74	140	80	74
160	60	74	160	70	74	160	80	74
180	60	74	180	70	74	180	80	74



TOP	L	SP	H
(120)	80	1,8	30
(140)	100	1,8	30
(160)	120	1,8	30
(180)	140	1,8	30

FENIX NTM®



Riparabilità termica dei micrograffi superficiali
Thermal healing of superficial microscratches
Réparation thermique des micro-rayures superficielles
Thermische Bearbeitung von oberflächlichen Kratzern
Reparabilidad térmica de microarañazos superficiales



Morbidezza al tatto
Soft touch
Toucher soyeux
Weicher Touch
Suave al tacto



Resistenza al calore secco
Resistance to dry heat
Résistance à la chaleur sèche
Resistent gegen trockene Hitze
Resistencia al calor seco



Bassa riflessione della luce, superficie estremamente opaca
Low light reflectivity, extremely matt surface
Faible réflectivité, surface extrêmement mate
Geringe Lichtreflexion, extrem matte Oberfläche
Reflexancia mínima de la luz, superficie extremadamente mate



Anti-impronta
Anti-fingerprint
Aucune trace de doigts
Keine Fingerabdrücke
Anti-huella digital



Resistenza ai graffi e all'abrasione
Resistance to scratches and abrasion
Résistance aux rayures et à l'abrasion
Resistent gegen Kratzer und Abrieb
Resistencia a los arañazos y a la abrasión



Alta attività di abbattimento della carica batterica
Enhanced anti-bacterial properties
Propriétés antibactériennes renforcées
Verbesserte antibakterielle Eigenschaften
Propiedad anti-bacterias reforzada



BIANCO KOS 0032
WHITE KOS 0032 / BLANC KOS 0032
WEISS KOS 0032/ BLANCO KOS 0032



NERO INGO 0720
BLACK INGO 0720/ NOIR INGO 0720
SCHWARZ INGO 0720/ NEGRO INGO 0720



GRIGIO LONDRA 0718
GREY LONDRA 0718/ GRIS LONDRA 0718
GRAU LONDRA 0718 / GRIS LONDRA 0718

H-TABLE

SISTEMA DI TAVOLI H.110 POLIFUNZIONALI IDEALI PER UN LAVORO TEMPORANEO O MEETING CHE FAVORISCONO IL CAMBIO DI POSTURA .

MULTI-PURPOSE TABLES SYSTEM H.110, IDEAL FOR A TEMPORARY WORK OR MEETING, WHICH FAVORISTS CHANGE OF POSTURE.







STRUTTURA METALLO

METAL FRAME / STRUCTURE METAL / METAL STRUKTUR / ESTRUCTURA METAL



VERNICIATO BIANCO RAL 9003
PAINTED WHITE

GRIGIO ALLUMINIO RAL9006
GREY ALUMINIUM

VERNICIATO NERO RAL 9005
PAINTED BLACK

PIANO SCRIVANIA NOBILITATO M1 DESK TOP MELAMINE M1



BIANCO
WHITE

GRIGIO
GREY

PIANO SCRIVANIA NOBILITATO M2 DESK TOP MELAMINE M2

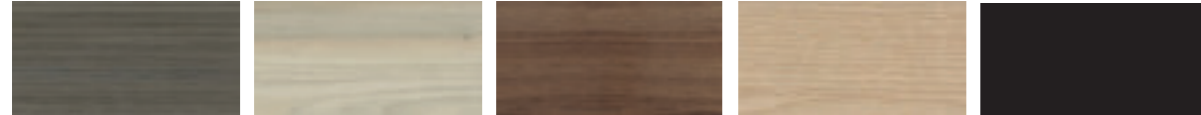

ROVERE GRIGIO
GREY OAK

NOCE SBIANCATO
BLEACHED WALNUT

NOCE CANALETTO
CANALETTO WALNUT

ROVERE
OAK

NERO
BLACK

FENIX NTM®

Riparabilità termica dei micrograffi superficiali
Thermal healing of superficial microscratches
Réparation thermique des micro-rayures superficielles
Thermische Bearbeitung von oberflächlichen Kratzern
Reparabilidad térmica de microarañazos superficiales

Morbidezza al tatto
Soft touch
Toucher soyeux
Weicher Touch
Suave al tacto

Resistenza al calore secco
Resistance to dry heat
Résistance à la chaleur sèche
Resistent gegen trockene Hitze
Resistencia al calor seco

Bassa riflessione della luce, superficie estremamente opaca
Low light reflectivity, extremely matt surface
Faible réflectivité, surface extrêmement mate
Geringe Lichtreflexion, extrem matte Oberfläche
Reflectancia mínima de la luz, superficie extremadamente mate

Anti-impronta
Anti-fingerprint
Aucune trace de doigts
Keine Fingerabdrücke
Anti-huella digital

Resistenza ai graffi e all'abrasione
Resistance to scratches and abrasion
Résistance aux rayures et à l'abrasion
Resisten gegen Kratzer und Abrieb
Resistencia a los arañazos y a la abrasion

Alta attività di abbattimento della carica batterica
Enhanced anti-bacterial properties
Propriétés antibactériennes renforcées
Verbesserte antibakterielle Eigenschaften
Propiedad anti-bacterias reforzada



BIANCO KOS 0032
WHITE KOS 0032 / BLANC KOS 0032
WEISS KOS 0032/ BLANCO KOS 0032



NERO INGO 0720
BLACK INGO 0720/ NOIR INGO 0720
SCHWARZ INGO 0720/ NEGRO INGO 0720



GRIGIO LONDRA 0718
GREY LONDRA 0718/ GRIS LONDRA 0718
GRAU LONDRA 0718 / GRIS LONDRA 0718

GRAFICI

GRAPHS / GRAPHIQUES / GRAPHS / GRAFICOS



60x60x110 H 60x80x110 H 60x100x110 H
80x60x110 H 80x80x110 H 80x100x110 H
100x60x110 H 100x80x110 H 100x100x110 H
120x60x110 H 120x80x110 H 120x100x110 H
140x60x110 H 140x80x110 H 140x100x110 H
160x60x110 H 160x80x110 H 160x100x110 H
180x60x110 H 180x80x110 H 180x100x110 H
200x60x110 H 200x80x110 H 200x100x110 H



240x60x110 H 240x80x110 H 240x100x110 H
280x60x110 H 280x80x110 H 280x100x110 H
320x60x110 H 320x80x110 H 320x100x110 H
360x60x110 H 360x80x110 H 360x100x110 H
400x60x110 H 400x80x110 H 400x100x110 H



360x60x110 H 360x80x110 H 360x100x110 H
420x60x110 H 420x80x110 H 420x100x110 H
480x60x110 H 480x80x110 H 480x100x110 H
540x60x110 H 540x80x110 H 540x100x110 H
600x60x110 H 600x80x110 H 600x100x110 H

Design innovativo per rispondere alle richieste di postazioni operative multifunzionali dalle varie composizioni , manager office moderni ed efficienti con soluzioni per un mercato globale ed integrato.

Innovative design for responding to requests of the various multifunctional compositions of workstations, office manager with modern and efficient solutions for a global and integrated market.



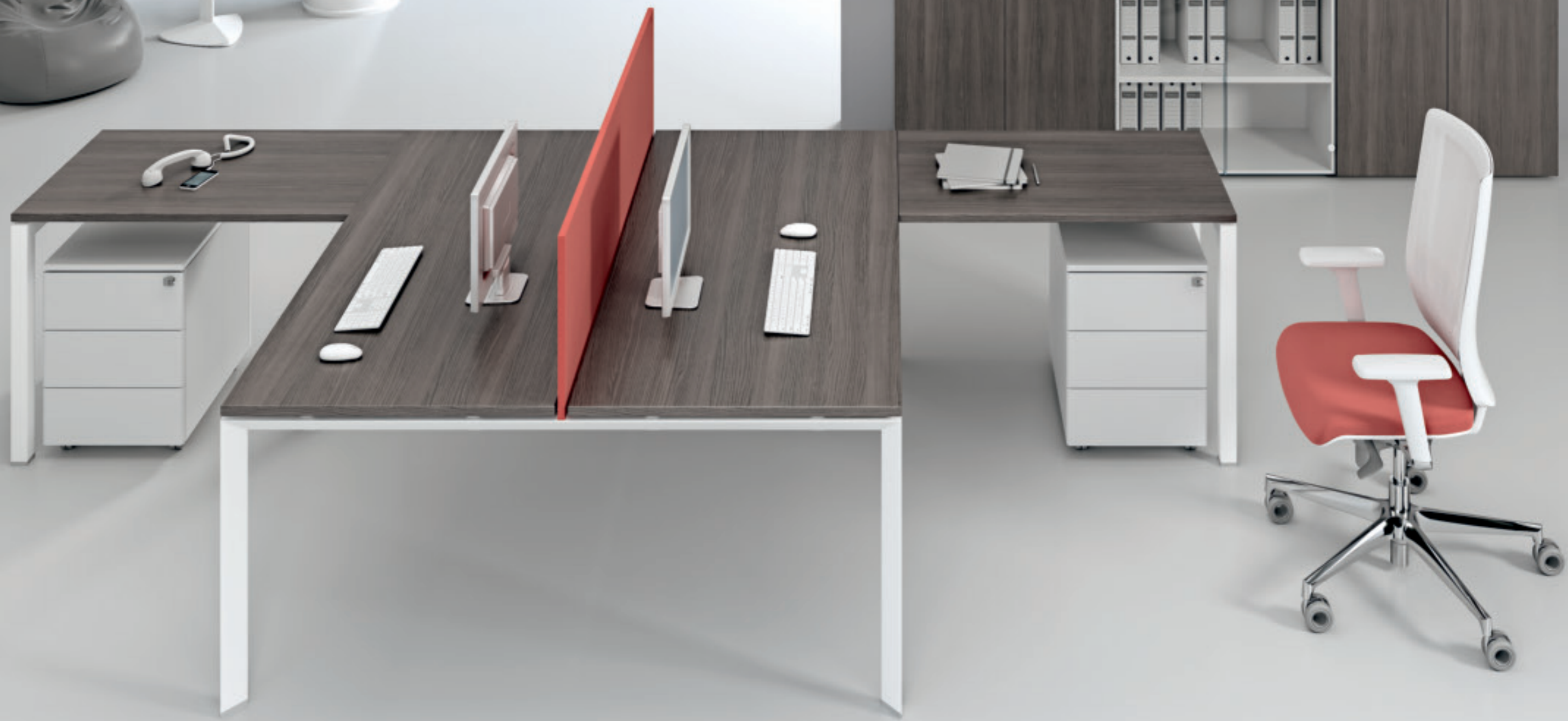





Il sistema Galaxy prevede elementi modulari che permettono un'ampia aggregabilità nelle molteplici tipologie di lavoro.

Galaxy system provides modular elements that allow aggregation in a wide variety of types of work.







Top access con sportello a chiusura ammortizzata e cablaggio integrato.

Top access with soft closing and integrate pwer socket.













STRUTTURA METALLO

METAL FRAME / STRUCTURE METAL / METAL STRUKTUR / ESTRUCTURA METAL



VERNICIATO BIANCO RAL 9003 PAINTED WHITE
GRIGIO ALLUMINIO RAL9006 GREY ALUMINIUM

PIANO NOBILITATO M2

TOP MELAMINE M2

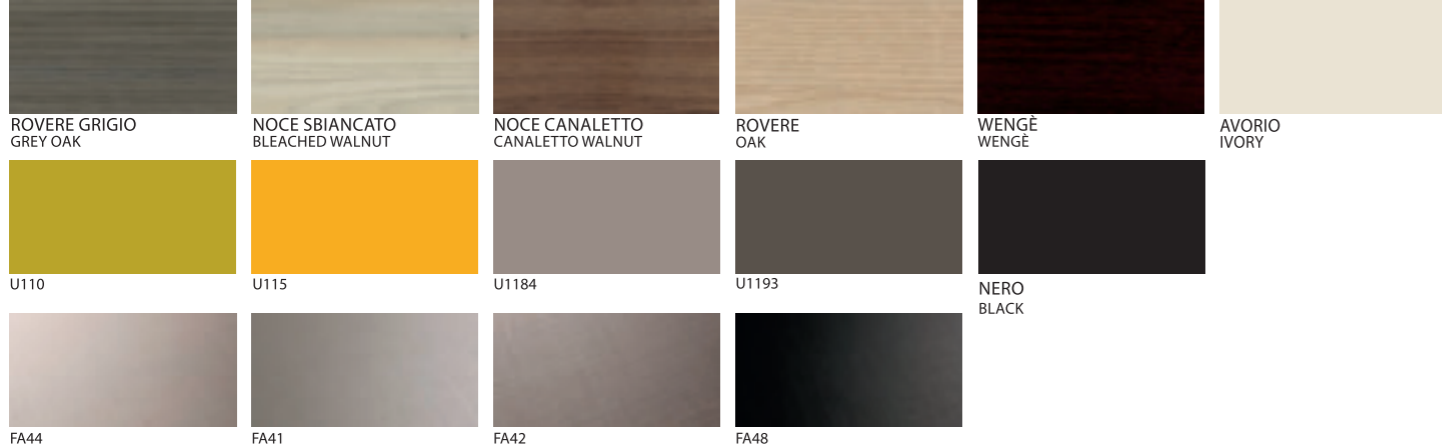

ROVERE GRIGIO GREY OAK
NOCE SBIANCATO BLEACHED WALNUT
NOCE CANALETTO CANALETTO WALNUT
ROVERE OAK
WENGÈ WENGÈ
AVORIO IVORY
U110 U115 U1184 U1193
NERO BLACK
FA44 FA41 FA42 FA48

CRISTALLO

GLASS / VERRE / KRISTALLGLAS / CRISTAL



NERO RAL 9005 BLACK
BIANCO RAL 9003 WHITE
ROSSO RAL 3002 RED
BLURAL 5002 BLUE
ARANCIO RAL 9004 ORANGE
ARGENTO RAL 9006 SILVER
MOKA RAL 8028 MOKA
GRIGIO ANTRACITE RAL7016 GREY ANTHRACITE
BIANCO EXTRACHIARO RAL9003 EXTRALIGHT WHITE

TESSUTO

FABRIC / ECRAN/ BILDSCHIRM/ PANTALLA



629 GRIGIO GREY / GRIS / GRAU / GRIS
625 GRIGIO SCURO GREY / GRIS / GRAU / GRIS
651 NERO BLACK / NOIR / SCHWARZ / NEGRO
386 BLU BLUE / BLEU / BLAU / AZUL
378 AVIO / BLUE AVIO BLEU AVIO / BLAU AVIO / AZUL AVIO
425 VERDE GREEN / VERTE / GRUN / VERDE
53 GIALLO YELLOW / JAUNE / GELB / AMARILLO
120 ARANCIO / ORANGE ORANGE / ORANGE / ANARANJADO
236 ROSSO RED / ROUGE / ROT / ROJO
175 PRUGNA PLUM / PRUNE / PFLAUME / CIRUELA
532 BEIGE BEIGE / BEIGE / BEIGE / BEIGE
534 MARRONE BROWN / MARRON / BRAUN / MARRON

PIANO NOBILITATO M1

TOP MELAMINE M1



BIANCO WHITE
GRIGIO GREY

FENIX NTM®

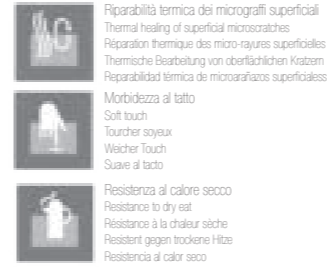

Riparabilità termica dei micrograffi superficiali
Thermal healing of superficial microscratches
Réparation thermique des micro-rayures superficielles
Thermische Bearbeitung von oberflächlichen Kratzern
Reparabilidad térmica de microarañazos superficiales

Morbidezza al tatto
Soft touch
Toucher soyeux
Weicher Touch
Suave al tacto

Resistenza al calore secco
Resistance to dry heat
Résistance à la chaleur sèche
Resistent gegen trockene Hitze
Resistencia al calor seco



Bassa riflessione della luce, superficie estremamente opaca
Low light reflectivity, extremely matt surface
Faible réflectivité, surface extrêmement mate
Geringe Lichtreflexion, extrem matte Oberfläche
Reflexión mínima de la luz, superficie extremadamente mate

Anti-impronta
Anti-fingerprint
Aucune trace de doigts
Keine Fingerabdrücke
Anti-huella digital

Resistenza ai graffi e all'abrasione
Resistance to scratches and abrasion
Résistance aux rayures et à l'abrasion
Resistent gegen Kratzer und Abrieb
Resistencia a los arañazos y a la abrasion

Alta attività di abbattimento della carica batterica
Enhanced anti-bacterial properties
Propriétés antibactériennes renforcées
Verbesserte antibakterielle Eigenschaften
Propiedad anti-bacterias reforzada



BIANCO KOS 0032
WHITE KOS 0032 / BLANC KOS 0032
WEISS KOS 0032/ BLANCO KOS 0032

NERO INGO 0720
BLACK INGO 0720/ NOIR INGO 0720
SCHWARZ INGO 0720/ NEGRO INGO 0720

GRIGIO LONDRA 0718
GREY LONDRA 0718/ GRIS LONDRA 0718
GRAU LONDRA 0718 / GRIS LONDRA 0718

GRAFICI
GRAPHS / GRAPHIQUES / GRAPHS / GRAFICOS



120X80X74 H
140X80X74 H
160X80X74 H
180X80X74 H
200X80X74 H

180X90X74 H
200X90X74 H
220X90X74 H
240X90X74 H

100X60X74 H

100X60X74 H

140X180X74 H
160X180X74 H
180X180X74 H
200X180X74 H

180X190X74 H
200X190X74 H
220X190X74 H
240X190X74 H



240X80X74 H
280X80X74 H
320X80X74 H
360X80X74 H
400X80X74 H

360X80X74 H
420X80X74 H
480X80X74 H
540X80X74 H
600X80X74 H

480X80X74 H
560X80X74 H
640X80X74 H
720X80X74 H
800X80X74 H

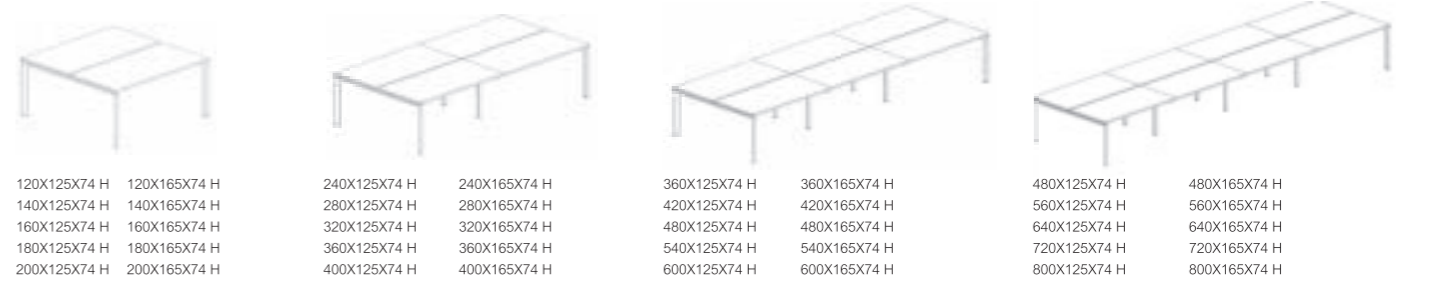

120X125X74 H
140X125X74 H
160X125X74 H
180X125X74 H
200X125X74 H

120X165X74 H
140X165X74 H
160X165X74 H
180X165X74 H
200X165X74 H

240X125X74 H
280X125X74 H
320X125X74 H
360X125X74 H
400X125X74 H

240X165X74 H
280X165X74 H
320X165X74 H
360X165X74 H
400X165X74 H

360X125X74 H
420X125X74 H
480X125X74 H
540X125X74 H
600X125X74 H

360X165X74 H
420X165X74 H
480X165X74 H
540X165X74 H
600X165X74 H

480X125X74 H
560X125X74 H
640X125X74 H
720X125X74 H
800X125X74 H

480X165X74 H
560X165X74 H
640X165X74 H
720X165X74 H
800X165X74 H



80X80X74 H
90X90X74 H
120X125X74 H
160X165X74 H

200X125X74 H
220X125X74 H
240X125X74 H

240X125X74 H
280X125X74 H
320X125X74 H
360X125X74 H
400X125X74 H

240X165X74 H
280X165X74 H
320X165X74 H
360X165X74 H
400X165X74 H

360X125X74 H
420X125X74 H
480X125X74 H
540X125X74 H
600X125X74 H

360X165X74 H
420X165X74 H
480X165X74 H
540X165X74 H
600X165X74 H



160X66X61,5 H
190X66X61,5 H

PROGRAMMA DI ARREDI CARATTERIZZATO DA TAVOLI
E COMPLEMENTI FUNZIONALI IN UN UNICO SISTEMA
COSTRUTTIVO.
VETRO, LEGNO E CUIO SI ALTERNANO SUI PIANI DI
LAVORO IN UN PERFETTO EQUILIBRIO ESTETICO.

FURNISHING PROGRAM CHARACTERIZED FROM
TABLES AND FUNCTIONAL ACCESSORIES IN A SINGLE
CONSTRUCTIVE SYSTEM.
GLASS, WOOD AND LEATHER ALTERNATE ON WORKING
TOP IN A PERFECT AESTHETIC PROPORTION.





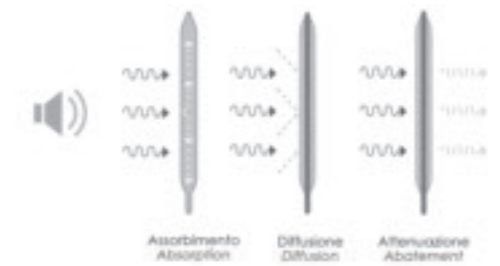
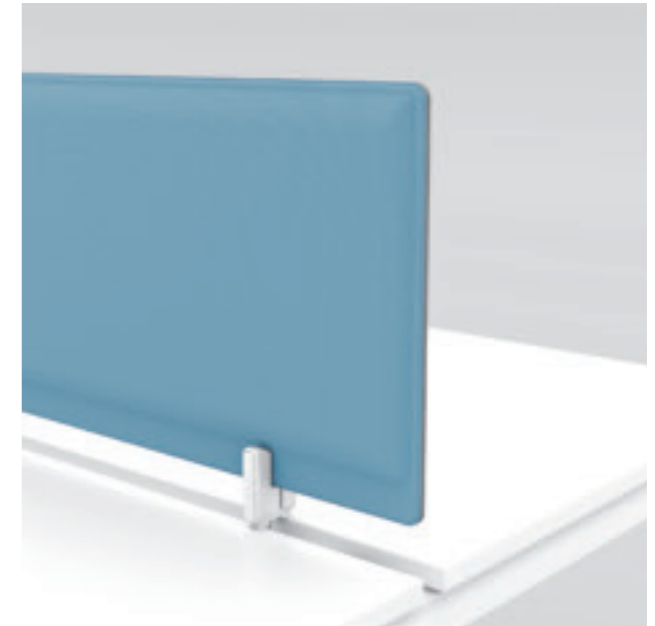

Pannello certificato secondo normativa UNI EN ISO 354
Certified panel according to regulation UNI EN ISO 11654

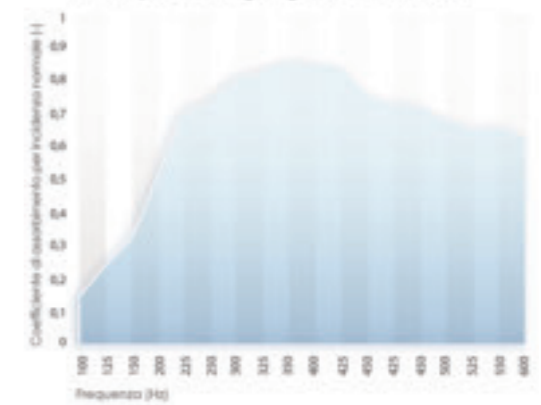









SLIDE

LED CL



STRUTTURA METALLO

METAL FRAME / STRUCTURE METAL / METAL STRUKTUR / ESTRUCTURA METAL

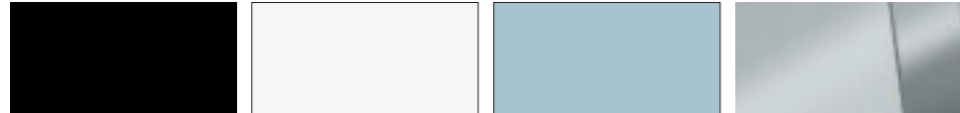

VERNICIATO NERO RAL 9005 PAINTED BLACK
 VERNICIATO BIANCO RAL 9003 PAINTED WHITE
 GRIGIO ALLUMINIO RAL9006 GREY ALUMINIUM
 CROMATO CHROME

ANTE, TOP, PIANO E FIANCHI DI FINITURA NOBILITATO M1

DOORS, TOP AND FINISHING SIDE MELAMINE M1



BIANCO WHITE
 GRIGIO GREY

ANTE, TOP, PIANO E FIANCHI DI FINITURA NOBILITATO M2

DOORS, TOP AND FINISHING SIDE MELAMINE M2



ROVERE GRIGIO GREY OAK
 NOCE SBIANCATO BLEACHED WALNUT
 NOCE CANALETTO CANALETTO WALNUT
 ROVERE OAK
 WENGÈ WENGÈ
 AVORIO IVORY



U110
 U115
 U1184
 U1193
 NERO BLACK



FA44
 FA41
 FA42
 FA48

PIANO CRISTALLO

GLASS TOP / PLATEAU VERRE / KRISTALLGLAS BRETT / PLAN CRISTAL

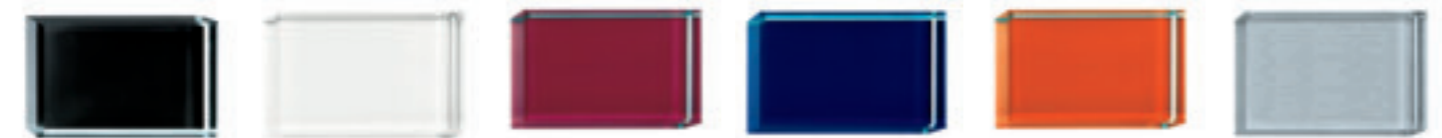

NERO RAL 9005 BLACK
 BIANCO RAL 9003 WHITE
 ROSSO RAL 3002 RED
 BLURAL 5002 BLUE
 ARANCIO RAL 9004 ORANGE
 ARGENTO RAL 9006 SILVER



MOKA RAL 8028 MOKA
 BIANCO EXTRACHIAIRO RAL9003 EXTRALIGHT WHITE
 GRIGIO ANTRACITE RAL7016 GREY ANTHRACITE

METACRILATO

METHACRYLATE / METHACRYLATE / METACRYLAT / METACRILATO



OPALINO OPAL
 VERDE MELA APPLE GREEN
 ARANCIO ORANGE
 AZZURRO BLUE

TESSUTO

FABRIC / ECRAN/ BILDSCHIRM/ PANTALLA



629 GRIGIO GREY / GRIS / GRAU / GRIS
 625 GRIGIO SCURO GREY / GRIS / GRAU / GRIS
 651 NERO BLACK / NOIR / SCHWARZ / NEGRO
 386 BLU BLUE / BLEU / BLAU / AZUL
 378 AVIO / BLUE AVIO BLEU AVIO / BLAU AVIO / AZUL AVIO
 425 VERDE GREEN / VERTE / GRUN / VERDE



53 GIALLO YELLOW / JAUNE / GELB / AMARILLO
 120 ARANCIO / ORANGE ORANGE / ORANGE / ANARANJADO
 236 ROSSO RED / ROUGE / ROT / ROJO
 175 PRUGNA PLUM / PRUNE / PFLAUME / CIRUELA
 532 BEIGE BEIGE / BEIGE / BEIGE / BEIGE
 534 MARRONE BROWN / MARRON / BRAUN / MARRON

FENIX NTM®

Riparabilità termica dei micrografi superficiali
 Thermal healing of superficial microscratches
 Réparation thermique des micro-rayures superficielles
 Thermische Bearbeitung von oberflächlichen Kratzern
 Reparabilidad térmica de microarañazos superficiales

Morbidezza al tatto
 Soft touch
 Toucher soyeux
 Weicher Touch
 Suave al tacto

Resistenza al calore secco
 Resistance to dry heat
 Résistance à la chaleur sèche
 Resistenz gegen trockene Hitze
 Resistencia al calor seco

Bassa riflessione della luce, superficie estremamente opaca
 Low light reflectivity, extremely matt surface
 Faible réflectivité, surface extrêmement mate
 Geringe Lichtreflexion, extrem matte Oberfläche
 Reflektividad mínima de la luz, superficie extremadamente mate

Anti-impronta
 Anti-fingerprint
 Aucune trace de doigts
 Keine Fingerabdrücke
 Anti-huella digital

Resistenza ai graffi e all'abrasione
 Resistance to scratches and abrasion
 Résistance aux rayures et à l'abrasion
 Resisten gegen Kratzer und Abrieb
 Resistencia a los arañazos y a la abrasión

Alta attività di abbattimento della carica batterica
 Enhanced anti-bacterial properties
 Propriétés antibactériennes renforcées
 Verbesserte antibakterielle Eigenschaften
 Propiedad anti-bacterias reforzada



BIANCO KOS 0032
 WHITE KOS 0032 / BLANC KOS 0032
 WEISS KOS 0032 / BLANCO KOS 0032



NERO INGO 0720
 BLACK INGO 0720/ NOIR INGO 0720
 SCHWARZ INGO 0720/ NEGRO INGO 0720



GRIGIO LONDRA 0718
 GREY LONDRA 0718/ GRIS LONDRA 0718
 GRAU LONDRA 0718 / GRIS LONDRA 0718

GRAFICI

GRAPHS / GRAPHIQUES / GRAPHS / GRAFICOS

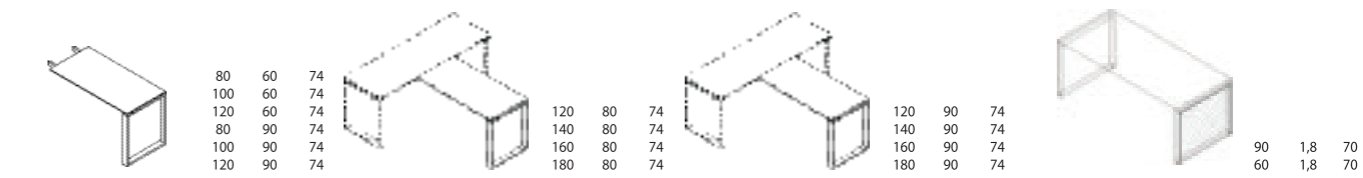
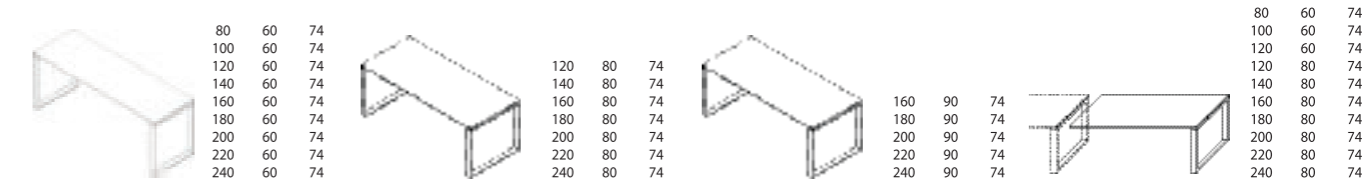

LED CL

SISTEMA INTEGRATO DAL CONCEPT DINAMICO E VERSATILE CHE SI ESPRIME IN LINEE FLUIDE E LEGGERE COINVOLGENDO TUTTI I LIVELLI DELL'AMBIENTE DI LAVORO: OPEN SPACE, WORKSTATION, EXECUTIVE E MEETING.

INTEGRATED SYSTEM FROM DINAMIC AND VERSATILE CONCEPT THAT EXPRESS ITSELF WITH FLUID AND LIGHT LINES, INVOLVING ALL LEVELS OF WORK AMBIANCE: OPEN SPACES, WORKSTATIONS, EXECUTIVES AND MEETINGS



SPAZI INDIVIDUALI
INDIVIDUAL SPACES

SPAZI CONDIVISI
SHARED SPACES











SLIDE

LED



WORKSTATION

LED





VERTICAL FILES

LED













MEETING

LED





STRUTTURA METALLO

METAL FRAME / STRUCTURE METAL / METAL STRUKTUR / ESTRUCTURA METAL



VERNICIATO NERO RAL 9005 PAINTED BLACK
VERNICIATO BIANCO RAL 9003 PAINTED WHITE
GRIGIO ALLUMINIO RAL9006 GREY ALUMINIUM
CROMATO CHROME

ANTE, TOP, PIANO E FIANCHI DI FINITURA NOBILITATO M1 DOORS, TOP AND FINISHING SIDE MELAMINE M



BIANCO WHITE
GRIGIO GREY

ANTE, TOP, PIANO E FIANCHI DI FINITURA NOBILITATO M2 DOORS, TOP AND FINISHING SIDE MELAMINE M2



ROVERE GRIGIO GREY OAK
NOCE SBIANCATO BLEACHED WALNUT
NOCE CANALETTO CANALETTO WALNUT
ROVERE OAK
WENGÈ WENGÈ
AVORIO IVORY



U110
U115
U1184
U1193
NERO BLACK



FA44
FA41
FA42
FA48

PIANO CRISTALLO

GLASS TOP / PLATEAU VERRE / KRISTALLGLAS BRETT / PLAN CRISTAL



NERO RAL 9005 BLACK
BIANCO RAL 9003 WHITE
ROSSO RAL 3002 RED
BLURAL 5002 BLUE
ARANCIO RAL 9004 ORANGE
ARGENTO RAL 9006 SILVER



MOKA RAL 8028 MOKA
BIANCO EXTRACHIARIO RAL9003 EXTRALIGHT WHITE
GRIGIO ANTRACITE RAL7016 GREY ANTHRACITE

METACRILATO

METHACRYLATE / METHACRYLATE / METACRYLAT / METACRILATO



OPALINO OPAL
VERDE MELA APPLE GREEN
ARANCIO ORANGE
AZZURRO BLUE

TESSUTO

FABRIC / ECRAN/ BILDSCHIRM/ PANTALLA



629 GRIGIO GREY / GRIS / GRAU / GRIS
625 GRIGIO SCURO GREY / GRIS / GRAU / GRIS
651 NERO BLACK / NOIR / SCHWARZ / NEGRO
386 BLU BLUE / BLEU / BLAU / AZUL
378 AVIO / BLUE AVIO BLEU AVIO / BLAU AVIO / AZUL AVIO
425 VERDE GREEN / VERTE / GRUN / VERDE



53 GIALLO YELLOW / JAUNE / GELB / AMARILLO
120 ARANCIO / ORANGE ORANGE / ORANGE / ANARANJADO
236 ROSSO RED / ROUGE / ROT / ROJO
175 PRUGNA PLUM / PRUNE / PFLAUME / CIRUELA
532 BEIGE BEIGE / BEIGE / BEIGE
534 MARRONE BROWN / MARRON / BRAUN / MARRON

FENIX NTM®



Riparabilità termica dei micrograffi superficiali
Thermal healing of superficial microscratches
Réparation thermique des micro-rayures superficielles
Thermische Bearbeitung von oberflächlichen Kratzern
Reparabilidad térmica de microarañazos superficiales



Morbidezza al tatto
Soft touch
Toucher soyeux
Weicher Touch
Suave al tacto



Resistenza al calore secco
Resistance to dry heat
Résistance à la chaleur sèche
Resistent gegen trockene Hitze
Resistencia al calor seco



Bassa riflessione della luce, superficie estremamente opaca
Low light reflectivity, extremely matt surface
Faible réflectivité, surface extrêmement mate
Geringe Lichtreflexion, extrem matte Oberfläche
Reflectancia mínima de la luz, superficie extremadamente mate



Anti-impronta
Anti-fingerprint
Aucune trace de doigts
Keine Fingerabdrucke
Anti-huella digital



Resistenza ai graffi e all'abrasione
Resistance to scratches and abrasion
Résistance aux rayures et à l'abrasion
Resisten gegen Kratzer und Abrieb
Resistencia a los arañazos y a la abrasion



Alta attività di abbattimento della carica batterica
Enhanced anti-bacterial properties
Propriétés antibactériennes renforcées
Verbesserte antibakterielle Eigenschaften
Propiedad anti-bacterias reforzada



BIANCO KOS 0032
WHITE KOS 0032 / BLANC KOS 0032
WEISS KOS 0032/ BLANCO KOS 0032



NERO INGO 0720
BLACK INGO 0720/ NOIR INGO 0720
SCHWARZ INGO 0720/ NEGRO INGO 0720



GRIGIO LONDRA 0718
GREY LONDRA 0718/ GRIS LONDRA 0718
GRAU LONDRA 0718 / GRIS LONDRA 0718

GRAFICI

GRAPHS / GRAPHIQUES / GRAPHS / GRAFICOS

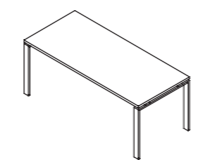

80 60 74
100 60 74
120 60 74
80 80 74
140 80 74
160 80 74
180 80 74
200 80 74

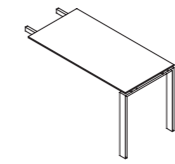

80 60 74
100 60 74
120 60 74
80 80 74
100 80 74
120 80 74

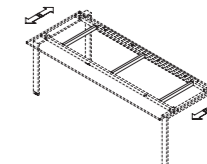

80 80 74
120 80 74
140 80 74
160 80 74
180 80 74
200 80 74

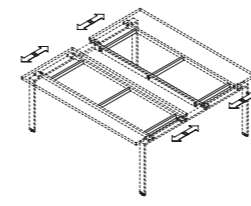

80 125 165 74
100 125 165 74
120 125 165 74
140 125 165 74
160 125 165 74
180 125 165 74
200 125 165 74

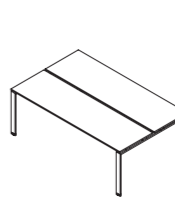

80 125 165 74
100 125 165 74
120 125 165 74
140 125 165 74
160 125 165 74
180 125 165 74
200 125 165 74

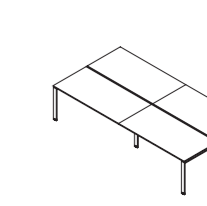

160 125 165
200 125 165
240 125 165
280 125 165
320 125 165
360 125 165
400 125 165

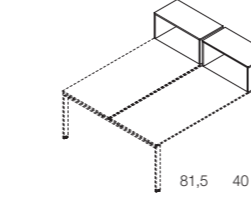

81,5 40 40

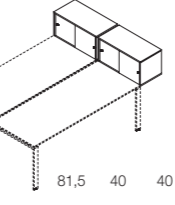

81,5 40 40

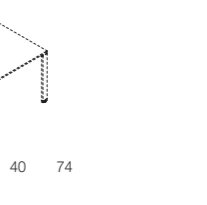

80 40 74



163 40 74

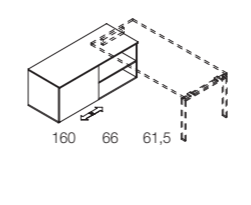

160 66 61,5

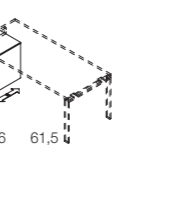

160 66 61,5

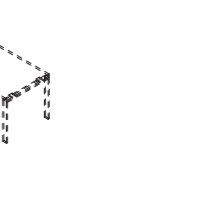

160 68 61,5

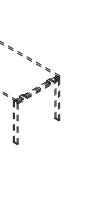

190 66 61,5

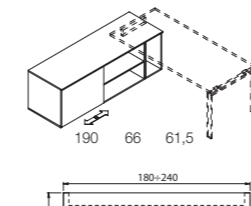

190 66 61,5

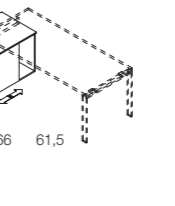

190 66 61,5

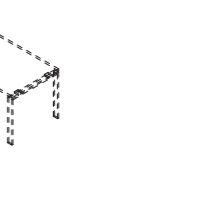

220 68 61,5



180 240
200 90 74
220 90 74
240 90 74

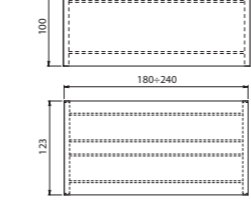

180 240
180 125 74
200 125 74
220 125 74
240 125 74

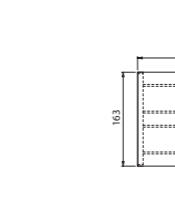

240 480
240 165 74
280 165 74
320 165 74
360 165 74
400 165 74
440 165 74
480 165 74

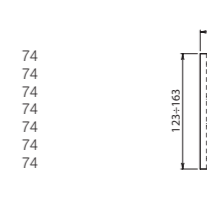

120 163
120 125 74
160 165 74

Linee Essenziali, ricercatezza di particolari, design innovativo per rispondere alle richieste di postazioni operative multifunzionali dalle varie composizioni , manager office moderni ed efficienti con soluzioni per un mercato globale ed integrato.

Essential lines, refined details, innovative design for responding to requests of the various multifunctional compositions of workstations, office manager with modern and efficient solutions for a global and integrated market.

U-FORM EVO













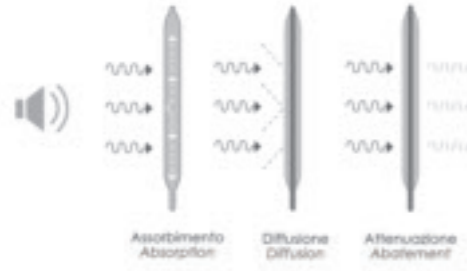
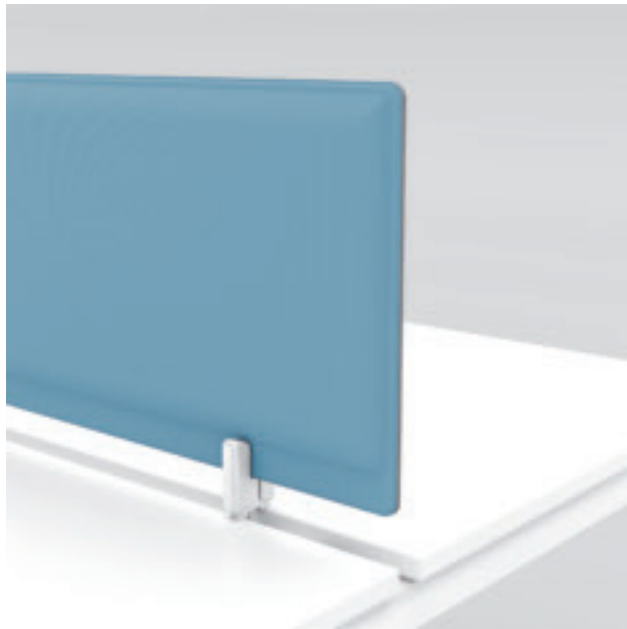

Pannello certificato secondo normativa UNI EN ISO 354
Certified panel according to regulation UNI EN ISO 11654

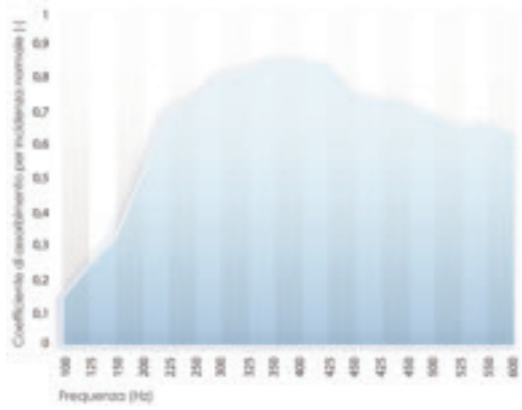

U-FORM EVO



U-FORM EVO













STRUTTURA METALLO

METAL FRAME / STRUCTURE METAL / METAL STRUKTUR / ESTRUCTURA METAL



VERNICIATO BIANCO RAL 9003
PAINTED WHITE

GRIGIO ALLUMINIO RAL9006
GREY ALUMINIUM

ANTE, TOP, PIANO E FIANCHI DI FINITURA NOBILITATO M1

DOORS, TOP AND FINISHING SIDE MELAMINE M1



BIANCO
WHITE

GRIGIO
GREY

ANTE, TOP, PIANO E FIANCHI DI FINITURA NOBILITATO M2

DOORS, TOP AND FINISHING SIDE MELAMINE M2



ROVERE GRIGIO
GREY OAK

NOCE SBIANCATO
BLEACHED WALNUT

NOCE CANALETTO
CANALETTO WALNUT

ROVERE
OAK

WENGÉ
WENGÉ

AVORIO
IVORY



U110

U115

U1184

U1193

NERO
BLACK



FA44

FA41

FA42

FA48

TESSUTO

FABRIC / ECRAN/ BILDSCHIRM/ PANTALLA



629 GRIGIO
GREY / GRIS / GRAU / GRIS

625 GRIGIO SCURO
GREY / GRIS / GRAU / GRIS

651 NERO
BLACK / NOIR / SCHWARZ / NEGRO

386 BLU
BLUE / BLEU / BLAU / AZUL

378 AVIO / BLUE AVIO
BLEU AVIO / BLAU AVIO / AZUL AVIO

425 VERDE
GREEN / VERTE / GRUN / VERDE



53 GIALLO
YELLOW / JAUNE / GELB / AMARILLO

120 ARANCIO / ORANGE
ORANGE / ORANGE / ANARANJADO

236 ROSSO
RED / ROUGE / ROT / ROJO

175 PRUGNA
PLUM / PRUNE / PFLAUME / CIRUELA

532 BEIGE
BEIGE / BEIGE / BEIGE / BEIGE

534 MARRONE
BROWN / MARRON / BRAUN / MARRON

FENIX NTM®

Riparabilità termica dei micrograffi superficiali
Thermal healing of superficial microscratches
Réparation thermique des micro-rayures superficielles
Thermische Bearbeitung von oberflächlichen Kratzern
Reparabilidad térmica de microarañazos superficiales

Morbidezza al tatto
Soft touch
Toucher soyeux
Weicher Touch
Suave al tacto

Resistenza al calore secco
Resistance to dry eat
Résistance à la chaleur sèche
Resistent gegen trockene Hitze
Resistencia al calor seco

Bassa riflessione della luce, superficie estremamente opaca
Low light reflectivity, extremely matt surface
Faible réflectivité, surface extrêmement mate
Geringe Lichtreflexion, extrem matte Oberfläche
Reflectancia mínima de la luz, superficie extremadamente mate

Anti-impronta
Anti-fingerprint
Aucune trace de doigts
Keine Fingerabdrücke
Anti-huella digital

Resistenza ai graffi e all'abrasione
Resistance to scratches and abrasion
Résistance aux rayures et à l'abrasion
Resisten gegen Kratzer und Abrieb
Resistencia a los arañazos y a la abrasion

Alta attività di abbattimento della carica batterica
Enhanced anti-bacterial properties
Propriétés antibactériennes renforcées
Verbesserte antibakterielle Eigenschaften
Propiedad anti-bacterias reforzada



BIANCO KOS 0032
WHITE KOS 0032 / BLANC KOS 0032
WEISS KOS 0032/ BLANCO KOS 0032



NERO INGO 0720
BLACK INGO 0720/ NOIR INGO 0720
SCHWARZ INGO 0720/ NEGRO INGO 0720



GRIGIO LONDRA 0718
GREY LONDRA 0718/ GRIS LONDRA 0718
GRAU LONDRA 0718 / GRIS LONDRA 0718

GRAFICI
GRAPHS / GRAPHIQUES / GRAPHS / GRAFICOS

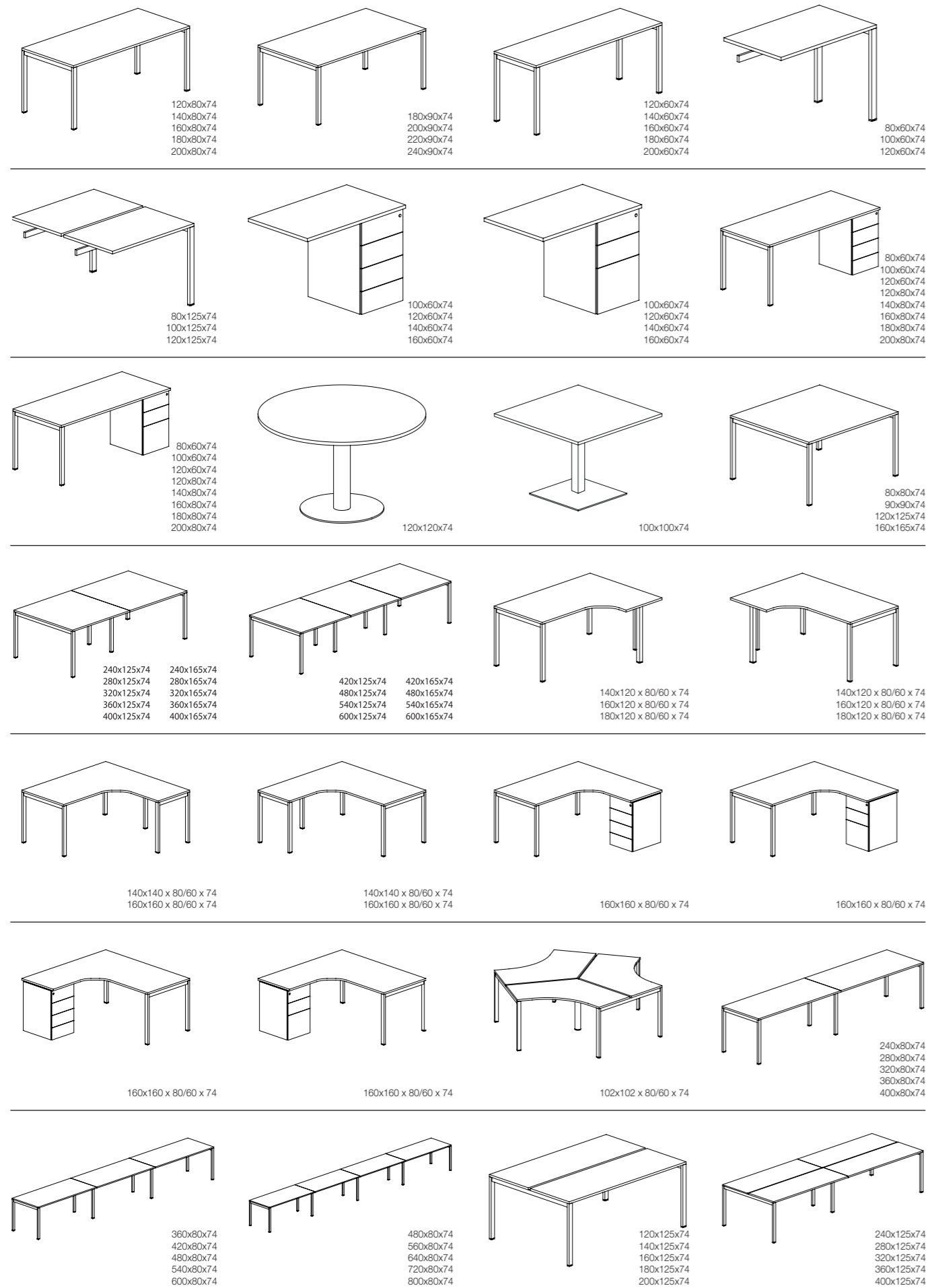

GRAFICI
GRAPHS / GRAPHIQUES / GRAPHS / GRAFICOS

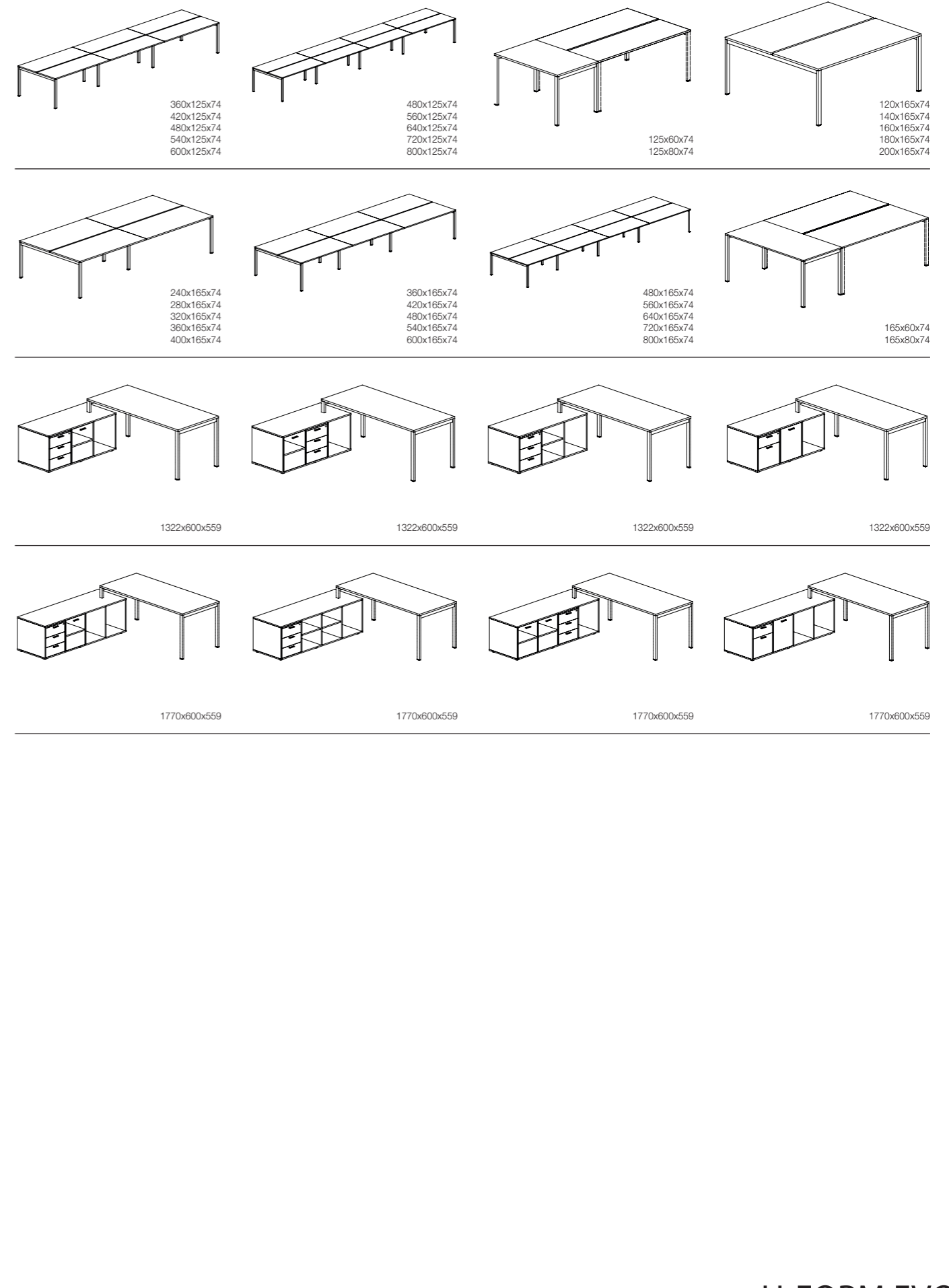

Linee Essenziali, ricercatezza di particolari, design innovativo per rispondere alle richieste di postazioni operative multifunzionali dalle varie composizioni , manager office moderni ed efficienti con soluzioni per un mercato globale ed integrato.

Essential lines, refined details, innovative design for responding to requests of the various multifunctional compositions of workstations, office manager with modern and efficient solutions for a global and integrated market.







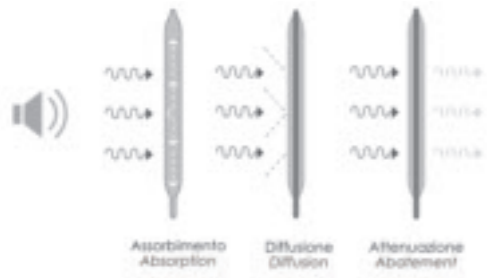
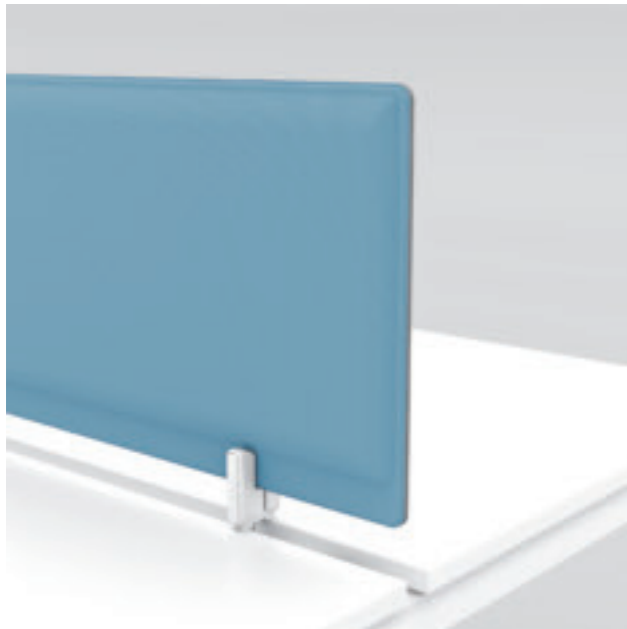

Pannello certificato secondo normativa UNI EN ISO 354
Certified panel according to regulation UNI EN ISO 11654

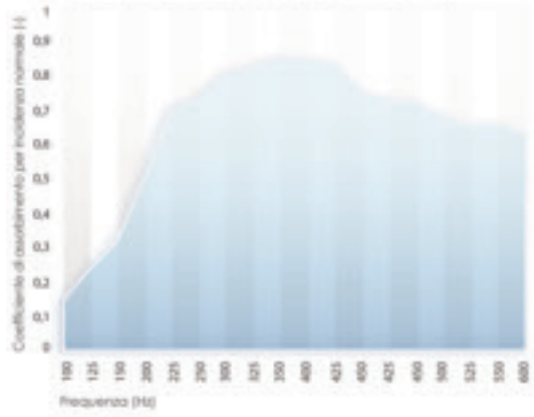













STRUTTURA METALLO

METAL FRAME / STRUCTURE METAL / METAL STRUKTUR / ESTRUCTURA METAL



VERNICIATO BIANCO RAL 9003
PAINTED WHITE

GRIGIO ALLUMINIO RAL9006
GREY ALUMINIUM

ANTE, TOP, PIANO E FIANCHI DI FINITURA NOBILITATO M1

DOORS, TOP AND FINISHING SIDE MELAMINE M1



BIANCO
WHITE

GRIGIO
GREY

ANTE, TOP, PIANO E FIANCHI DI FINITURA NOBILITATO M2

DOORS, TOP AND FINISHING SIDE MELAMINE M2



ROVERE GRIGIO
GREY OAK

NOCE SBIANCATO
BLEACHED WALNUT

NOCE CANALETTO
CANALETTO WALNUT

ROVERE
OAK

WENGÈ
WENGÈ

AVORIO
IVORY



U110

U115

U1184

U1193

NERO
BLACK



FA44

FA41

FA42

FA48

TESSUTO

FABRIC / ECRAN/ BILDSCHIRM/ PANTALLA



629 GRIGIO
GREY / GRIS / GRAU / GRIS

625 GRIGIO SCURO
GREY / GRIS / GRAU / GRIS

651 NERO
BLACK / NOIR / SCHWARZ / NEGRO

386 BLU
BLUE / BLEU / BLAU / AZUL

378 AVIO / BLUE AVIO
BLEU AVIO / BLAU AVIO / AZUL AVIO

425 VERDE
GREEN / VERTE / GRUN / VERDE



53 GIALLO
YELLOW / JAUNE / GELB / AMARILLO

120 ARANCIO / ORANGE
ORANGE / ORANGE / ANARANJADO

236 ROSSO
RED / ROUGE / ROT / ROJO

175 PRUGNA
PLUM / PRUNE / PFLAUME / CIRUELA

532 BEIGE
BEIGE / BEIGE / BEIGE / BEIGE

534 MARRONE
BROWN / MARRON / BRAUN / MARRON

FENIX NTM®

 Riparabilità termica dei micrograffi superficiali
Thermal healing of superficial microscratches
Réparation thermique des micro-rayures superficielles
Thermische Bearbeitung von oberflächlichen Kratzern
Reparabilidad térmica de microarañazos superficiales

 Morbidezza al tatto
Soft touch
Toucher soyeux
Weicher Touch
Suave al tacto

 Resistenza al calore secco
Resistance to dry eat
Résistance à la chaleur sèche
Resistent gegen trockene Hitze
Resistencia al calor seco

 Bassa riflessione della luce, superficie estremamente opaca
Low light reflectivity, extremely matt surface
Faible réflectivité, surface extrêmement mate
Geringe Lichtreflexion, extrem matte Oberfläche
Reflectancia mínima de la luz, superficie extremadamente mate

 Anti-impronta
Anti-fingerprint
Aucune trace de doigts
Keine Fingerabdrücke
Anti-huella digital

 Resistenza ai graffi e all'abrasione
Resistance to scratches and abrasion
Résistance aux rayures et à l'abrasion
Resisten gegen Kratzer und Abrieb
Resistencia a los arañazos y a la abrasión

 Alta attività di abbattimento della carica batterica
Enhanced anti-bacterial properties
Propriétés antibactériennes renforcées
Verbesserte antibakterielle Eigenschaften
Propiedad anti-bacterias reforzada



BIANCO KOS 0032
WHITE KOS 0032 / BLANC KOS 0032
WEISS KOS 0032/ BLANCO KOS 0032



NERO INGO 0720
BLACK INGO 0720/ NOIR INGO 0720
SCHWARZ INGO 0720/ NEGRO INGO 0720



GRIGIO LONDRA 0718
GREY LONDRA 0718/ GRIS LONDRA 0718
GRAU LONDRA 0718 / GRIS LONDRA 0718

GRAFICI
GRAPHS / GRAPHIQUES / GRAPHS / GRAFICOS

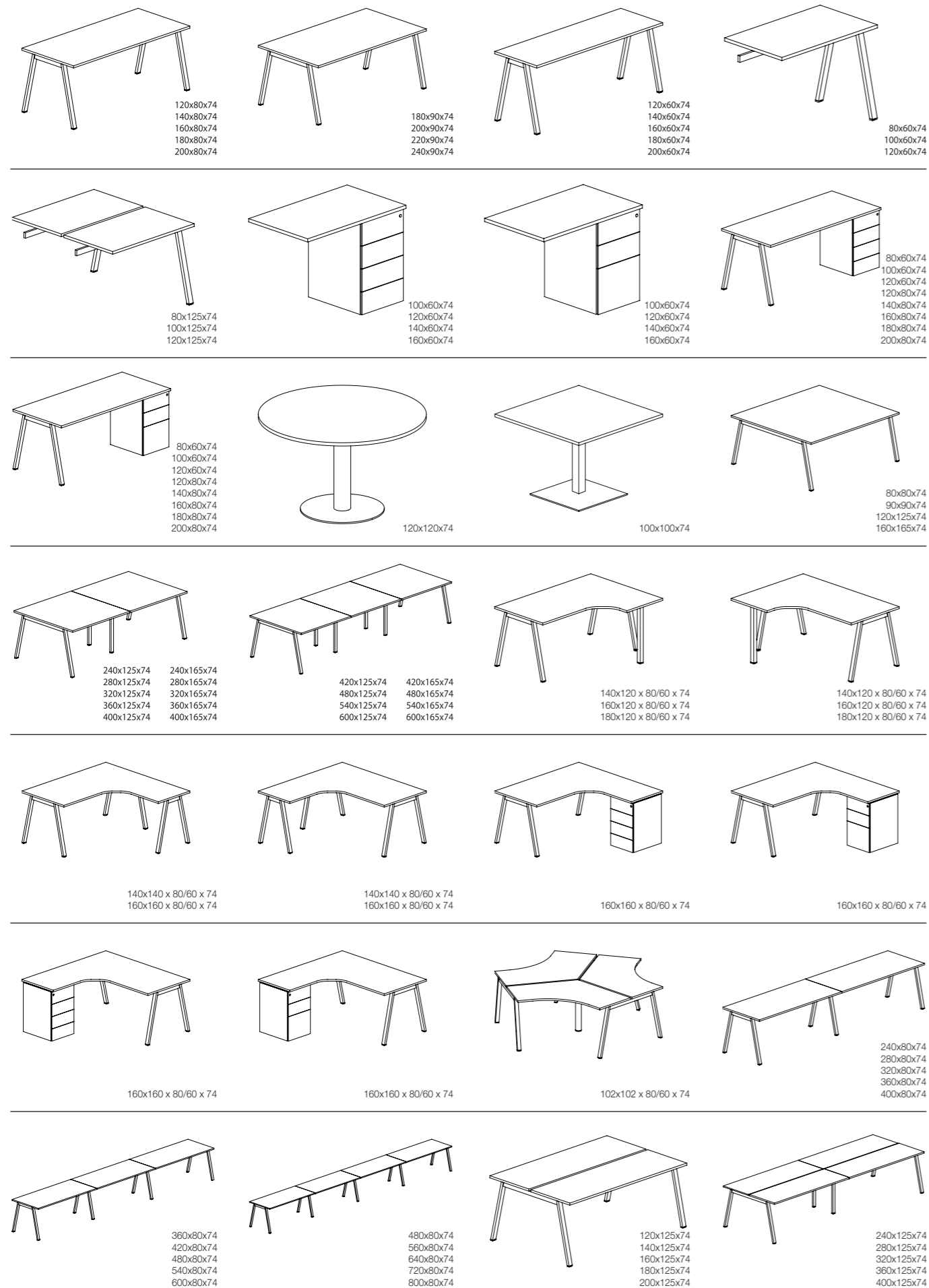

GRAFICI
GRAPHS / GRAPHIQUES / GRAPHS / GRAFICOS

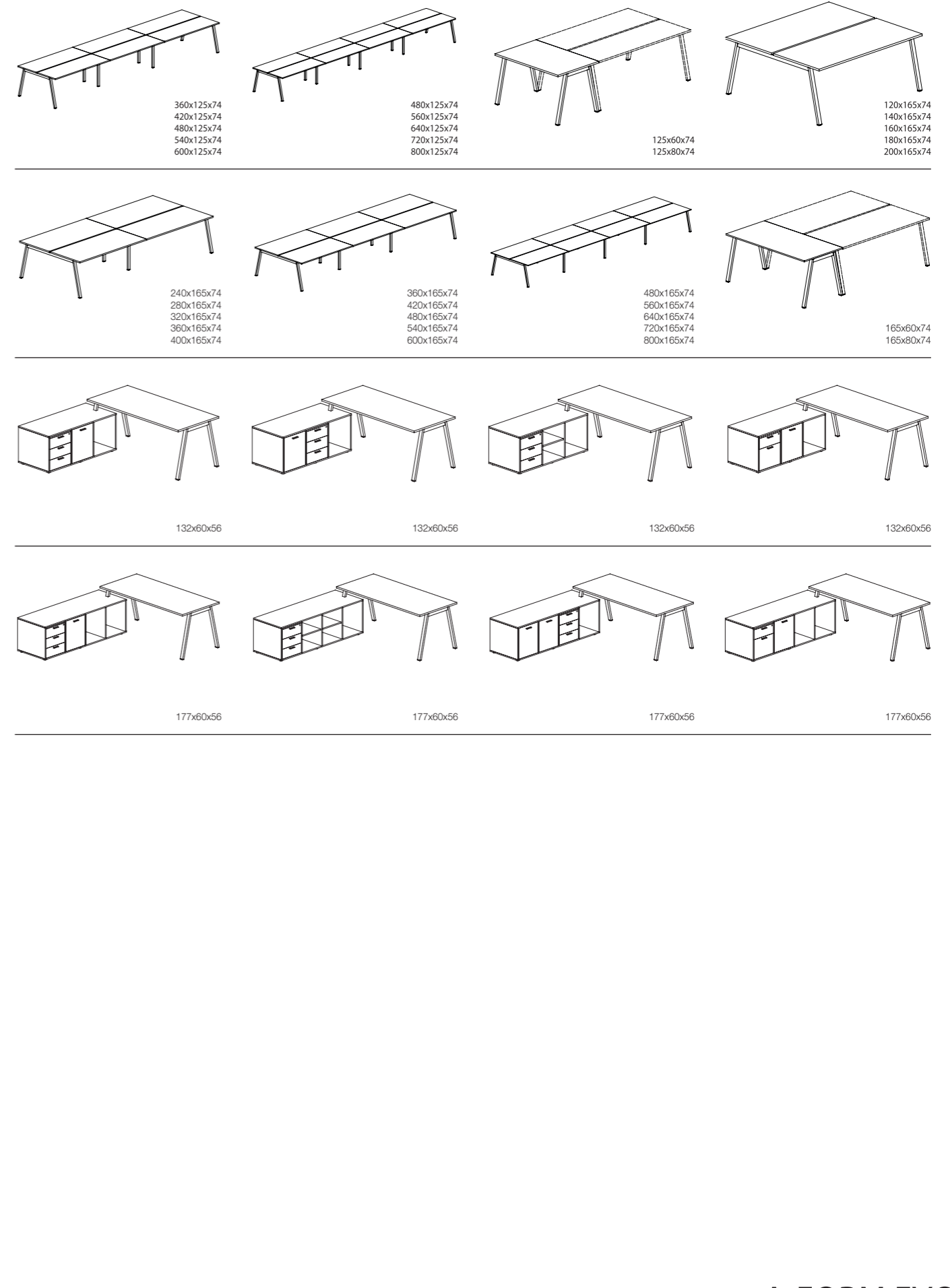

TAB È UN SISTEMA INTEGRATO PER L'ARREDAMENTO DI UFFICI OPERATIVI CHE È STATO PROGETTATO NELL'OTTICA DI UN LARGO IMPIEGO, PENSANDO ALLA GRANDE FUNZIONALITÀ UNITA SEMPRE ALLA NECESSARIA GRADEVOLEZZA ESTETICA: L'INSIEME DELLE SUE CARATTERISTICHE PRINCIPALI LO CLASSIFICANO NATURALMENTE IN UNA POSIZIONE DI ESTREMA FLESSIBILITÀ E CONFIGURAZIONE PERSONALIZZATA. GRAZIE AI PROPRI ELEMENTI COORDINABILI E MODULARI, TAB È ADATTO A RISOLVERE QUALSIASI ESIGENZA DI SPAZIO.

TUTTE LE FINITURE DI NOBILITATO SP. 25 MM SONO AD ALTA RESISTENZA CONTRO I GRAFFI E L'USURA.

LE SCRIVANIE DEL SISTEMA TAB SONO DOTATE DI TRAVI TELESCOPICHE PASSACAVI CHE PERMETTONO DI OTTENERE UN OTTIMO RISULTATO ESTETICO E FUNZIONALE.

LE GAMBE METALLICHE SONO ISPEZIONABILI GRAZIE AD UN CARTER ESTERNO FACILMENTE RIMOVIBILE; LE SCRIVANIE SONO ANCHE ELEVABILI IN ALTEZZA (68/82 CM), RENDENDO PIÙ RAZIONALE E MENO FATICOLO IL LAVORO DEGLI OPERATORI.

TAB IS AN INTEGRATED SYSTEM FOR THE FURNISHING OF OPERATING OFFICES THAT WAS DESIGNED WITH A VIEW TO A LARGE EMPLOYMENT, THINKING OF THE GREAT FUNCTIONALITY COMBINED WITH ATTRACTIVE APPEARANCE ALWAYS NECESSARY.

THANKS TO ITS MODULAR AND COORDINATE ELEMENTS, TAB IS SUITABLE TO SOLVE ANY REQUIREMENT OF SPACE.

ALL MELAMINE FINISHES OF 30 MM TH. HAVE HIGH RESISTANCE AGAINST SCRATCHES AND WEAR.

TAB DESKS SYSTEM ARE FURNISHED WITH TELESCOPIC PASSAGE-CABLES BEAMS WHICH COULD ACHIEVE A GOOD AESTHETIC AND FUNCTIONAL RESULT.

THE METALLIC LEGS COULD BE INSPECTED THROUGH AN OUTER CASING EASILY REMOVABLE; ALL DESKS ARE ADJUSTABLE HEIGHT (68/82 CM), MAKING THE WORK OF OPERATORS MORE FUNCTIONAL AND LESS HARD.













STRUTTURA METALLO

METAL FRAME / STRUCTURE METAL / METAL STRUKTUR / ESTRUCTURA METAL

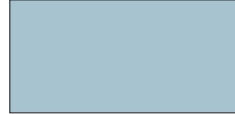

GRIGIO ALLUMINIO RAL9006
GREY ALUMINIUM

PIANO SCRIVANIA NOBILITATO M1

DESK TOP MELAMINE M1



BIANCO
WHITE



GRIGIO
GREY

PIANO NOBILITATO M2

TOP MELAMINE M2

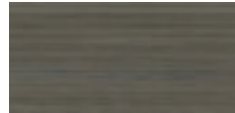

ROVERE GRIGIO
GREY OAK



NOCE SBIANCATO
BLEACHED WALNUT

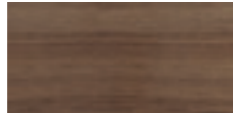

NOCE CANALETTO
CANALETTO WALNUT



ROVERE
OAK



WENGÈ
WENGÈ

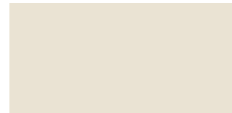

AVORIO
IVORY



NERO
BLACK

TESSUTO

FABRIC / ECRAN/ BILDSCHIRM/ PANTALLA



629 GRIGIO
GREY / GRIS / GRAU / GRIS

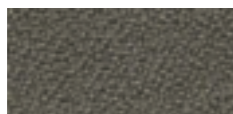

625 GRIGIO SCURO
GREY / GRIS / GRAU / GRIS



651 NERO
BLACK / NOIR / SCHWARZ / NEGRO



386 BLU
BLUE / BLEU / BLAU / AZUL



378 AVIO / BLUE AVIO
BLEU AVIO / BLAU AVIO / AZUL AVIO



425 VERDE
GREEN / VERTE / GRUN / VERDE



53 GIALLO
YELLOW / JAUNE / GELB / AMARILLO



120 ARANCIO / ORANGE
ORANGE / ORANGE / ANARANJADO



236 ROSSO
RED / ROUGE / ROT / ROJO



175 PRUGNA
PLUM / PRUNE / PFLAUME / CIRUELA



532 BEIGE
BEIGE / BEIGE / BEIGE / BEIGE



534 MARRONE
BROWN / MARRON / BRAUN / MARRON

FENIX NTM®



Riparabilità termica dei micrograffi superficiali
Thermal healing of superficial microscratches
Réparation thermique des micro-rayures superficielles
Thermische Bearbeitung von oberflächlichen Kratzern
Reparabilidad térmica de microarañazos superficiales



Morbidezza al tatto
Soft touch
Toucher soyeux
Weicher Touch
Suave al tacto



Resistenza al calore secco
Resistance to dry heat
Résistance à la chaleur sèche
Resistent gegen trockene Hitze
Resistencia al calor seco



Bassa riflessione della luce, superficie estremamente opaca
Low light reflectivity, extremely matt surface
Faible réflectivité, surface extrêmement mate
Geringe Lichtreflexion, extrem matte Oberfläche
Reflexion mínima de la luz, superficie extremadamente mate



Anti-impronta
Anti-fingerprint
Aucune trace de doigts
Keine Fingerabdrücke
Anti-huella digital



Resistenza ai graffi e all'abrasione
Resistance to scratches and abrasion
Résistance aux rayures et à l'abrasion
Resisten gegen Kratzer und Abrieb
Resistencia a los arañazos y a la abrasión



Alta attività di abbattimento della carica batterica
Enhanced anti-bacterial properties
Propriétés antibactériennes renforcées
Verbesserte antibakterielle Eigenschaften
Propiedad anti-bacterias reforzada



BIANCO KOS 0032
WHITE KOS 0032 / BLANC KOS 0032
WEISS KOS 0032/ BLANCO KOS 0032



NERO INGO 0720
BLACK INGO 0720/ NOIR INGO 0720
SCHWARZ INGO 0720/ NEGRO INGO 0720



GRIGIO LONDRA 0718
GREY LONDRA 0718/ GRIS LONDRA 0718
GRAU LONDRA 0718 / GRIS LONDRA 0718

GRAFICI

GRAPHS / GRAPHIQUES / GRAPHS / GRAFICOS

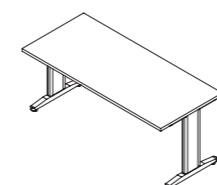

120x80x74
140x80x74
160x80x74
180x80x74
200x80x74

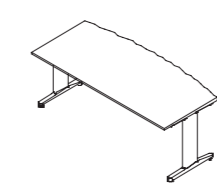

180x80/90x74
200x80/90x74

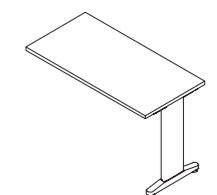

80x60x74
100x60x74
120x60x74

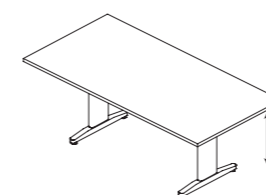

200x100x74
240x100x74

TAVOLO RIUNIONI

FINITURE E FORME DIVERSE CARATTERIZZATE DA UNA VASTA MODULARITÀ PER ARREDARE QUALSIASI SPAZIO MEETING.

FINISHES AND DIFFERENT SHAPES CHARACTERIZED BY A VAST MODULARITY TO FURNISH ANY MEETING SPACE.











FINITURE E COLORI

FINISHINGS AND COLORS / FINITIONS ET COULEURS / OBERFLACHE UND FARBEN / ACABADOS Y COLORES

STRUTTURA METALLO

METAL FRAME / STRUCTURE METAL / METALL STRUKTUR / ESTRUCTURA METAL



VERNICIATO BIANCO RAL 9003
PAINTED WHITE



GRIGIO ALLUMINIO RAL 9006
GREY ALUMINIUM

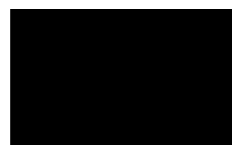

VERNICIATO NERO RAL 9005
PAINTED BLACK



CROMATO
CHROME

PIANO NOBILITATO M1

TOP MELAMINE M1

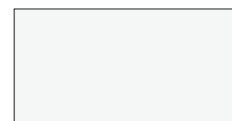

BIANCO
WHITE



GRIGIO
GREY

PIANO NOBILITATO M2

TOP MELAMINE M2



ROVERE GRIGIO
GREY OAK



NOCE SBIANCATO
BLEACHED WALNUT



NOCE CANALETTO
CANALETTO WALNUT



ROVERE
OAK



WENGÈ
WENGÈ

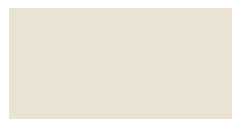

AVORIO
IVORY



NERO
BLACK

CRISTALLO

GLASS / VERRE / KRISTALLGLAS / CRISTAL



NERO RAL 9005
BLACK



BIANCO RAL 9003
WHITE



ROSSO RAL 3002
RED



BLURAL 5002
BLUE



ARANCIO RAL 9004
ORANGE



ARGENTO RAL 9006
SILVER



MOKA RAL 8028
MOKA



GRIGIO ANTRACITE RAL7016
GREY ANTHRACITE



ACIDATO
ETCHED



BIANCO EXTRACHIARO RAL9003
EXTRALIGHT WHITE

GRAFICI

GRAPHS / GRAPHIQUES / GRAPHS / GRAFICOS



100x100x74



ø 100x74
ø 120x74



ø 100x74
ø 120x74



240x110x74



240x80/110x74



240x110x74



200x100x74
240x110x74



350x80/110x74



350x110x74



350x110x74

TAVOLI MULTITASKING ADATTI AD AREE LOUNGE E BREAK
 GRAZIE ALLE DUE ALTEZZE H.50 E H.110.

MULTITASKING TABLES SUITABLE FOR LOUNGE AND BREAK
 AREAS THANKS TO THE 2 HEIGHTS 50 AND 110 CM.











FINITURE E COLORI

FINISHINGS AND COLORS / FINITIONS ET COULEURS / OBERFLACHE UND FARBEN / ACABADOS Y COLORES

STRUTTURA METALLO

METAL FRAME / STRUCTURE METAL / METALL STRUKTUR / ESTRUCTURA METAL



VERNICIATO BIANCO RAL 9003
PAINTED WHITE



GRIGIO ALLUMINIO RAL 9006
GREY ALUMINIUM

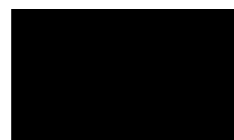

VERNICIATO NERO RAL 9005
PAINTED BLACK

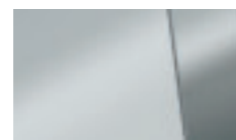

CROMATO
CHROME

PIANO NOBILITATO M1

TOP MELAMINE M1



BIANCO
WHITE



GRIGIO
GREY

PIANO NOBILITATO M2

TOP MELAMINE M2



ROVERE GRIGIO
GREY OAK



NOCE SBIANCATO
BLEACHED WALNUT



NOCE CANALETTO
CANALETTO WALNUT



ROVERE
OAK



WENGÈ
WENGÈ

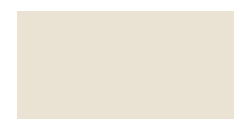

AVORIO
IVORY



NERO
BLACK

GRAFICI

GRAPHS / GRAPHIQUES / GRAPHS / GRAFICOS



Ø 50x50 H
Ø 60x50 H
Ø 70x50 H



Ø 60x110 H
Ø 70x110 H
Ø 80x110 H
Ø 100x110 H



140x80x110 H
160x80x110 H

FENIX NTM®



Riparabilità termica dei micrograffi superficiali
Thermal healing of superficial microscratches
Réparation thermique des micro-rayures superficielles
Thermische Bearbeitung von oberflächlichen Kratzern
Reparabilidad térmica de microarañazos superficiales



Morbidezza al tatto
Soft touch
Toucher soyeux
Weicher Touch
Suave al tacto



Resistenza al calore secco
Resistance to dry heat
Résistance à la chaleur sèche
Resistent gegen trockene Hitze
Resistencia al calor seco



Bassa riflessione della luce, superficie estremamente opaca
Low light reflectivity, extremely matt surface
Faible réflectivité, surface extrêmement mate
Geringe Lichtreflexion, extrem matte Oberfläche
Reflectancia mínima de la luz, superficie extremadamente mate



Anti-impronta
Anti-fingerprint
Aucune trace de doigts
Keine Fingerabdrücke
Anti-huella digital



Resistenza ai graffi e all'abrasione
Resistance to scratches and abrasion
Résistance aux rayures et à l'abrasion
Resisten gegen Kratzer und Abrieb
Resistencia a los arañazos y a la abrasion



Alta attività di abbattimento della carica batterica
Enhanced anti-bacterial properties
Propriétés antibactériennes renforcées
Verbesserte antibakterielle Eigenschaften
Propiedad anti-bacterias reforzada



BIANCO KOS 0032
WHITE KOS 0032 / BLANC KOS 0032
WEISS KOS 0032/ BLANCO KOS 0032



NERO INGO 0720
BLACK INGO 0720/ NOIR INGO 0720
SCHWARZ INGO 0720/ NEGRO INGO 0720



GRIGIO LONDRA 0718
GREY LONDRA 0718/ GRIS LONDRA 0718
GRAU LONDRA 0718 / GRIS LONDRA 0718

MODULI CONTENITIVI DESTINATI ALLA CUSTODIA DI OGGETTI E DOCUMENTI PERSONALI CARATTERIZZATI DA UNA MOLTEPLICE MODULARITÀ E UNA VASTA GAMMA DI FINITURE. DISPONIBILI CON DIVERSE TIPOLOGIE DI SERRATURE AL FINE DI GARANTIRE LA PRIVACY.

CONTAINMENT MODULES FOR STORAGE PERSONAL OBJECTS AND DOCUMENTS CHARACTERIZED BY A MULTIPLE MODULARITY AND WIDE RANGE OF FINISHES. AVAILABLE WITH DIFFERENT TYPES OF LOCKS IN ORDER TO GUARANTEE PRIVACY.





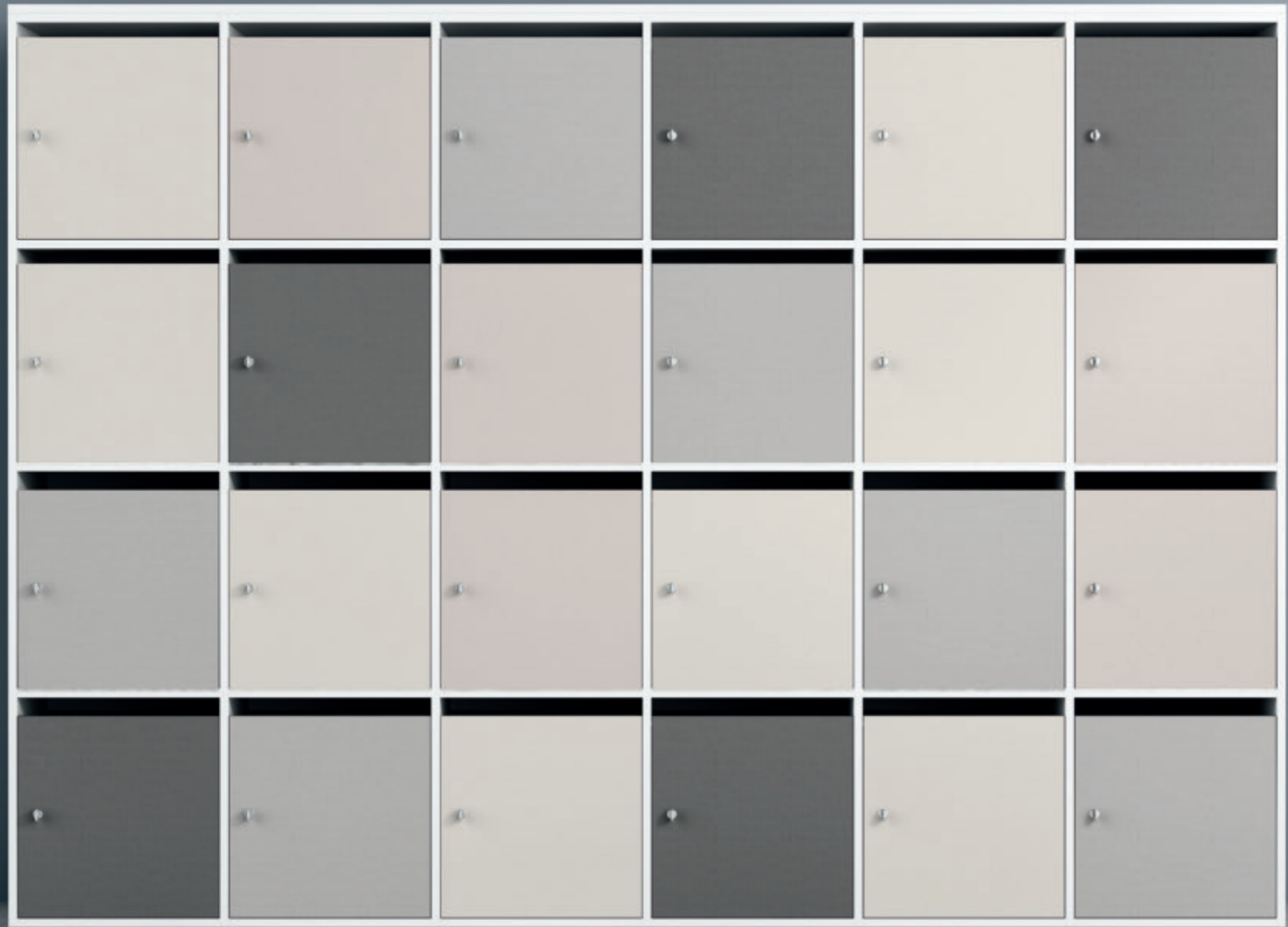

RECEPTION

IL PROGRAMMA RECEPTION FORMATO DA ELEMENTI CURVI E LINEARI PERMETTE DIFFERENTI CONFIGURAZIONI D'ARREDO A SECONDA DELLE ESIGENZE DI SPAZIALITÀ. LA QUALITÀ, L'ACCURATEZZA E LE FINITURE DEI MATERIALI IMPIEGATI, SODDISFANO TUTTE LE ESIGENZE DEGLI OPERATORI.

RECEPTION PROGRAM IS MADE UP FROM LINEAR AND CURVED ELEMENTS WHICH ALLOW DIFFERENT CONFIGURATIONS OF FURNITURE IN ACCORDANCE WITH THE REQUIREMENTS OF SPACE. THE QUALITY, ACCURACY AND FINISHING MATERIALS, SATISFY ALL REQUIREMENTS OF THE OPERATORS.









PIANO NOBILITATO M1

TOP MELAMINE M1



BIANCO
WHITE

GRIGIO
GREY

PIANO NOBILITATO M2

TOP MELAMINE M2



ROVERE GRIGIO
GREY OAK

NOCE SBIANCATO
BLEACHED WALNUT

NOCE CANALETTO
CANALETTO WALNUT

ROVERE
OAK

WENGÈ
WENGÈ



U110

U115

U1184

U1193

NERO
BLACK

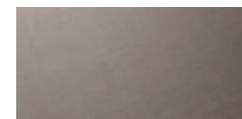

FA44

FA41

FA42

FA48

LACCATO OPACO LISCIO

LACQUERED OPAQUE SMOOTH / LAQUÉ OPAQUE LISSE / OPAKE LACKIERT / LACADO



9005 NERO
BLACK

4056 ARANCIO
ORANGE

0222 BLU OCEANO
OCEAN BLUE

1019 TORTORA
TURTLEDOVE

0259 GRIGIO GRAFITE
GRAPHITE GREY

6023 ROSSO
RED

0220 AZZURRO RODI
RODI BLUE



4057 VERDE MELA
APPLE GREEN

0244 GRIGIO
METALLIZZATO
METALLIC GREY

0164 ROSSO
RUBINO
RUBY RED

0139 GIALLO
CROMO
CHROME YELLOW

0197 VERDE PAMPA
PAMPAS GREEN

3097 AZZURRO CIELO
SKY BLUE

GRAFICI

GRAPHS / GRAPHIQUES / GRAPHS / GRAFICOS

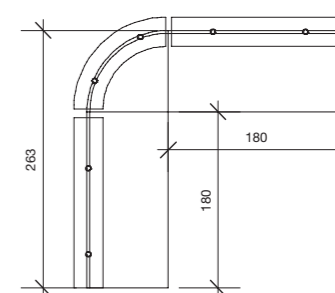
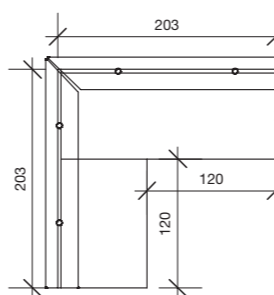
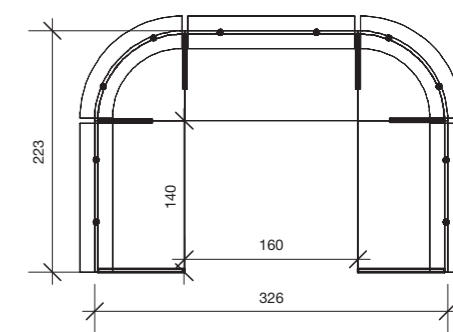
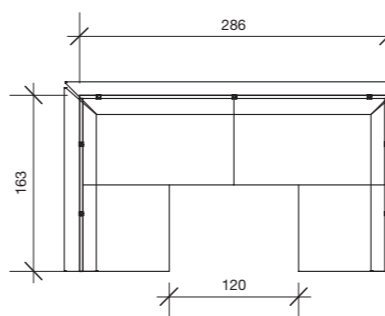
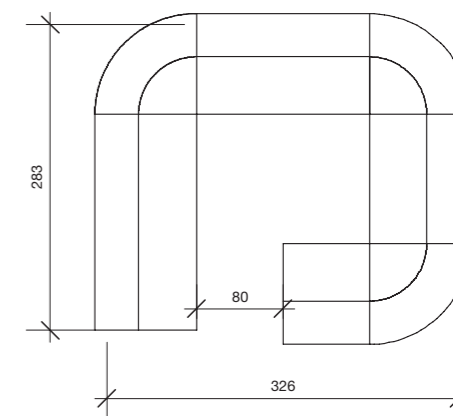
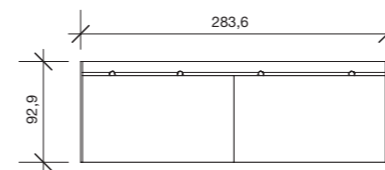

CASSETTIERE MELAMINICO
MELAMINE PEDESTALS



CASSETTIERE

CASSETTIERE METALLO
METAL PEDESTALS



CHARACTERIZING AESTHETICS AND VERSATILITY FOR TOMO SYSTEM, A SYSTEM OF MODULES AVAILABLE IN DIFFERENT OPTIONS, PENING A WORLD OF OPPORTUNITY AND POSSIBILITY OF USES.

ESTETICA E VERSATILITA CARATTERIZZANTI PER TOMO SYSTEM, UN SISTEMA DI MODULI DISPONIBILI IN NUMEROSE VARIANTI, APRENDO UN MONDO DI POSSIBILITA' E POSSIBILITA' D'USO.













FINITURE E COLORI

FINISHINGS AND COLORS / FINITIONS ET COULEURS / OBERFLACHE UND FARBEN / ACABADOS Y COLORES

STRUTTURA

FRAME / STRUCTURE / STRUKTUR / ESTRUCTURA



BIANCO
WHITE

GRIGIO
GRAY

NERO
BLACK

ANTE, TOP, PIANO E FIANCHI DI FINITURA NOBILITATO M1

DOORS, TOP AND FINISHING SIDE MELAMINE M1 / PORTES, TOP ET COTÉS DE FINITION MELAMINE M1

TÜREN, TOP UND ABSCHLUSSFLANKS MELAMINE M1 / PUERTAS, PLANO Y COSTADO DE CIERRE MELAMINE M1



BIANCO
WHITE

GRIGIO
GREY

ANTE, TOP, PIANO E FIANCHI DI FINITURA NOBILITATO M2

DOORS, TOP AND FINISHING SIDE MELAMINE M2 / PORTES, TOP ET COTÉS DE FINITION MELAMINE M2

TÜREN, TOP UND ABSCHLUSSFLANKS MELAMINE M2 / PUERTAS, PLANO Y COSTADO DE CIERRE MELAMINE M2

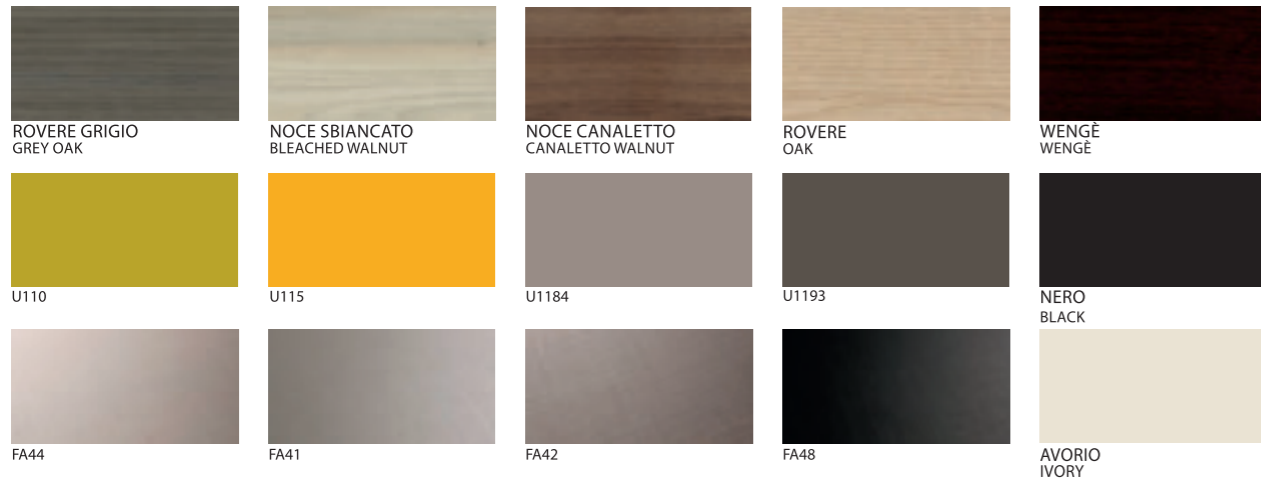

ROVERE GRIGIO
GREY OAK

NOCE SBIANCATO
BLEACHED WALNUT

NOCE CANALETTO
CANALETTO WALNUT

ROVERE
OAK

WENGÈ
WENGÈ

U110

U115

U1184

U1193

NERO
BLACK

FA44

FA41

FA42

FA48

AVORIO
IVORY

FENIX NTM®

Bassa riflessione della luce, superficie estremamente opaca
Low light reflectivity, extremely matt surface
Faible réflectivité, surface extrêmement mate
Geringe Lichtreflexion, extrem matte Oberfläche
Reflectancia mínima de la luz, superficie extremadamente mate

Anti-impronta
Anti-fingerprint
Aucune trace de doigts
Keine Fingerabdrücke
Anti-huella digital

Resistenza ai graffi e all'abrasione
Resistance to scratches and abrasion
Résistance aux rayures et à l'abrasion
Resisten gegen Kratzer und Abrieb
Resistencia a los arañazos y a la abrasion

Alta attività di abbattimento della carica batterica
Enhanced anti-bacterial properties
Propriétés antibactériennes renforcées
Verbesserte antibakterielle Eigenschaften
Propiedad anti-bacterias reforzada

Riparabilità termica dei micrografi superficiali
Thermal healing of superficial microscratches
Réparation thermique des micro-rayures superficielles
Thermische Bearbeitung von oberflächlichen Kratzern
Reparabilidad térmica de microarañazos superficiales

Morbidità al tatto
Soft touch
Toucher soyeux
Weicher Touch
Suave al tacto

Resistenza al calore secco
Resistance to dry heat
Résistance à la chaleur sèche
Resistent gegen trockene Hitze
Resistencia al calor seco

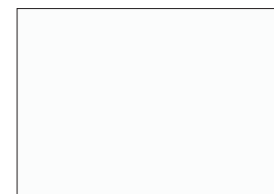

BIANCO KOS 0032
WHITE KOS 0032 / BLANC KOS 0032
WEISS KOS 0032 / BLANCO KOS 0032



NERO INGO 0720
BLACK INGO 0720/ NOIR INGO 0720
SCHWARZ INGO 0720/ NEGRO INGO 0720



GRIGIO LONDRA 0718
GREY LONDRA 0718/ GRIS LONDRA 0718
GRAU LONDRA 0718 / GRIS LONDRA 0718

FINITURE E COLORI

FINISHINGS AND COLORS / FINITIONS ET COULEURS / OBERFLACHE UND FARBEN / ACABADOS Y COLORES

ANTA ESSENZA

VENEER DOOR, PORTE BOIS, TUEREN HOLZ, PORTA MADERA



ACERO
MAPLE

FAGGIO
BEECH

ROVERE SBIANCATO
BLEACHED OAK

WENGÈ
WENGÈ

NOCE AMERICANO
AMERICAN WALNUT

ROVERE SMOKED
SMOKED OAK

LACCATO OPACO LISCIO

LACQUERED OPAQUE SMOOTH / LAQUÉ OPAQUE LISSE / OPAKE LACKIERT / LACADO



9005 NERO
9005 BLACK

4056 ARANCIO
4056 ORANGE

0222 BLU OCEANO
0222 OCEAN BLUE

1019 TORTORA
1019 TURTLEDOVE

0259 GRIGIO GRAFITE
GRAPHITE GRAY

6023 ROSSO
6023 RED



0220 AZZURRO RODI
0220 RODI BLUE



4057 VERDE MELA
4057 APPLE GREEN



0244 GRIGIO ALLUMINIO
0244 ALUMINUM GRAY



0164 ROSSO RUBINO
0164 RUBY RED



0139 GIALLO CROMO
0139 CHROME YELLOW



0197 VERDE PAMPA
0197 PAMPAS GREEN



4063 MARRONE
4063 BROWN

TUTTI GLI ARMADI SONO AGGREGABILI E SOVRAPPONIBILI, CON MODULARITÀ IN LARGHEZZA: CM 90 E CM 45. SI COMPONGONO COSÌ BEN SEI ALTEZZE, CON LA POSSIBILITÀ, SFRUTTANDO I DUE MODULI IN LARGHEZZA, DI RAGGIUNGERE CON PRECISIONE LA MISURA PIÙ IDONEA ALLA PARETE.

ALL THE CABINETS ARE AFFILIATABLE AND SUPERPOSABLE, WITH MODULARITY IN WIDTH: CM 90 AND CM 45. SIX HEIGHTS ARE MADE UP VERY THEREFORE, WITH THE POSSIBILITY, TAKING ADVANTAGE OF THE TWO MODULES IN WIDTH, TO CATCH UP WITH PRECISION THE MORE SUITABLE MEASURE TO THE WALL.





h. 81

h. 119

h. 158

h. 196

h. 235

h. 268







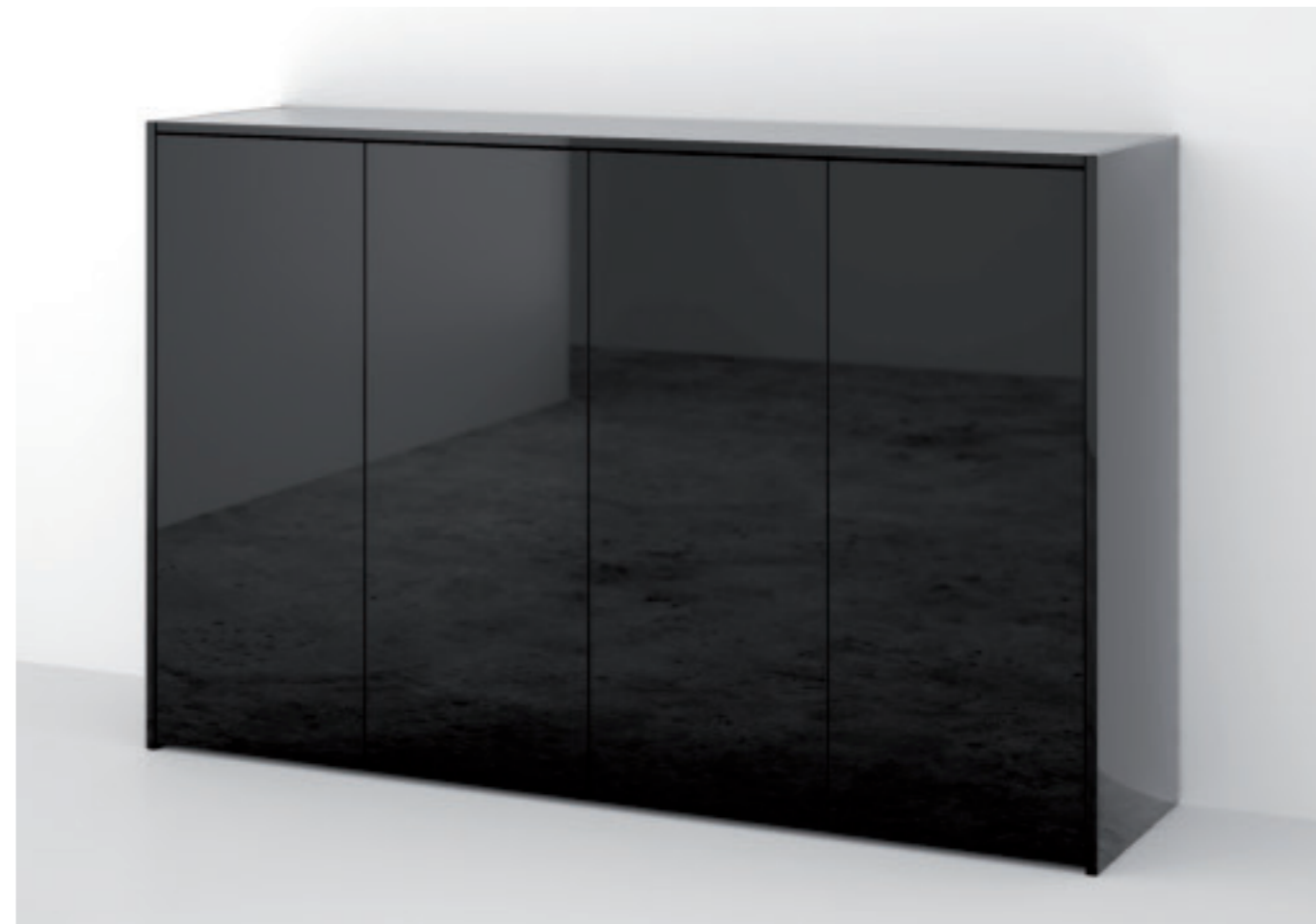



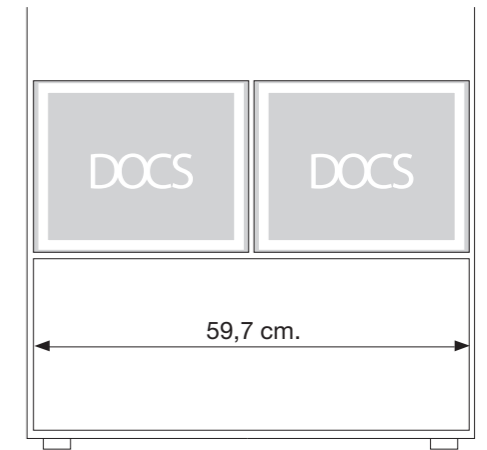
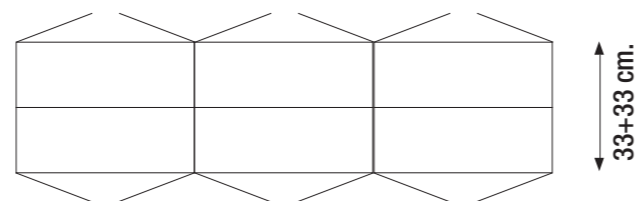

PROFONDITÀ
33 10 ARMADI 4 SCRIVANIE
 10 CABINETS 4 DESKS

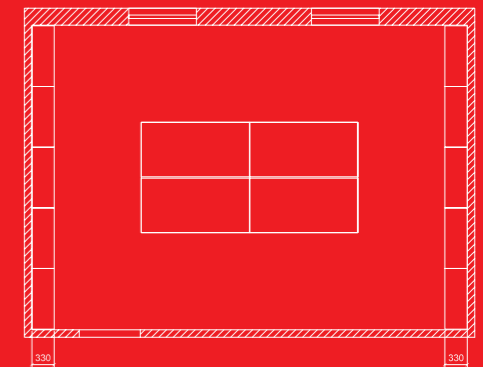

PROFONDITÀ
63 5 ARMADI 6 SCRIVANIE
 5 CABINETS 6 DESKS

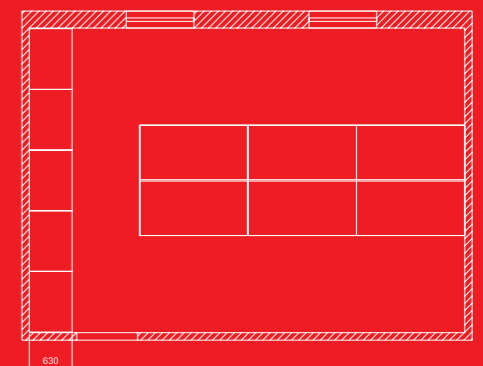





FINITURE E COLORI

FINISHINGS AND COLORS / FINITIONS ET COULEURS / OBERFLACHE UND FARBEN / ACABADOS Y COLORES

STRUTTURA E ANTE NOBILITATO M1

STRUCTURE AND DOORS MELAMINE M1 / STRUCTURE, PORTES MELAMINE M1
KORPUSSE, TÜREN MELAMINE M1 / ESTRUCTURA, PUERTAS MELAMINE M1



BIANCO
WHITE

GRIGIO
GREY

ANTE TOP E FIANCHI DI FINITURA NOBILITATO M2

DOORS, TOP AND FINISHING SIDE MELAMINE M2 / PORTES, TOP ET COTÉS DE FINITION MELAMINE M2
TÜREN, TOP UND ABSCHLUSSFLANKS MELAMINE M2 / PUERTAS, PLANO Y COSTADO DE CIERRE MELAMINE M2

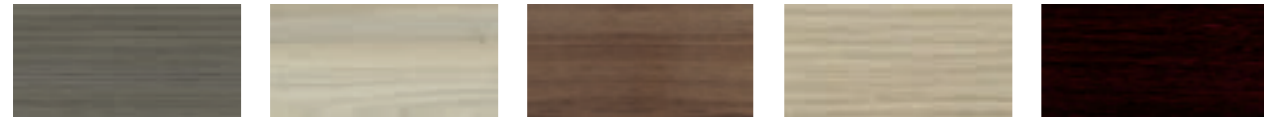

ROVERE GRIGIO
GREY OAK

NOCE SBIANCATO
BLEACHED WALNUT

NOCE CANALETTO
CANALETTO WALNUT

ROVERE
OAK

WENGÈ
WENGÉ



U110

U115



U1184

U1193



NERO
BLACK

AVORIO
IVORY



FA44

FA41

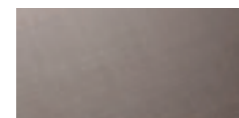

FA42

FA48

STRUTTURA E ANTE NOBILITATO M3

STRUCTURE AND DOORS MELAMINE M3 / STRUCTURE, PORTES MELAMINE M3
KORPUSSE, TÜREN MELAMINE M3 / ESTRUCTURA, PUERTAS MELAMINE M3

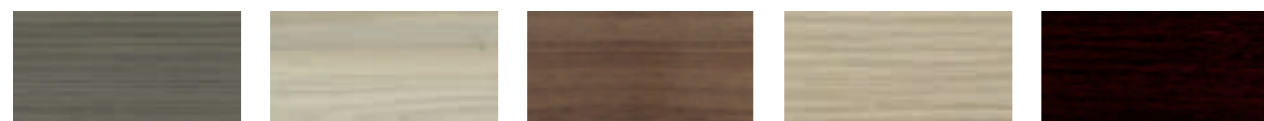

ROVERE GRIGIO
GREY OAK

NOCE SBIANCATO
BLEACHED WALNUT

NOCE CANALETTO
CANALETTO WALNUT

ROVERE
OAK

WENGÈ
WENGÉ



U110

U115



U1184

U1193



NERO
BLACK

AVORIO
IVORY



FA44

FA41



FA42

FA48

ANTA ESSENZA

WOOD DOOR / PORTES EN BOIS / TÜREN HOLZBRETT / PORTE MADERA



ACERO
MAPLE

FAGGIO
BEECH

ROVERE SBIANCATO
BLEACHED OAK

WENGÈ
WENGÉ

NOCE AMERICANO
AMERICAN WALNUT

ROVERE SMOKED
SMOKED OAK

LACCATO OPACO LISCIO

LACQUERED OPAQUE SMOOTH / LAQUÉ OPAQUE LISSE / OPAKE LACKIERT / LACADO



9005 NERO
9005 BLACK

4056 ARANCIO
4056 ORANGE

0222 BLU OCEANO
0222 OCEAN BLUE

1019 TORTORA
1019 TURTLEDOVE

0259 GRIGIO GRAFITE
GRAPHITE GRAY

6023 ROSSO
6023 RED



0220 AZZURRO RODI
0220 RODI BLUE

4057 VERDE MELA
4057 APPLE GREEN

0244 GRIGIO ALLUMINIO
0244 ALUMINUM GRAY

0164 ROSSO RUBINO
0164 RUBY RED

0139 GIALLO CROMO
0139 CHROME YELLOW

0197 VERDE PAMPA
0197 PAMPAS GREEN

4063 MARRONE
4063 BROWN

LACCATO LUCIDO

GLOSSY LACQUERED / LAQUE BRILIANT / GLANZLACK / LACADO PULIDO



RAL 9003 BIANCO
WHITE / BLANC
WEISS / BLANCO

RAL 9001 AVORIO
IVORY / IVOIRE
IVORY / MARFIL

RAL 1019 TORTORA
TURTLEDOVE / TOURTERELLE
TURTELTAUBE / TORTOLA

RAL 8019 MARRONE
BROWN / MARRON
BRAUN / MARRON

RAL 9005 NERO
BLACK / NOIR
SCHWARZ / NEGRO

RAL 3002 ROSSO
RED / ROUGE
ROT / ROJO

CUOIO

LEATHER / CUIR / LEDER / CUERO



BIANCO
WHITE / BLANC
WEISS / BLANCO

NATURALE
NATURAL / NATUREL
NATURALENT / NATURAL

TABACCO
TOBACCO / TABAC
TABAK / TABACO

ARANCIO
ORANGE / ORANGE
ORANGE / ANARANJADO



ROSSO BULGARO
BULGARIAN RED / ROUGE BULGARE /
BULGARISCHE ROT / ROJA BULGARA



GRIGIO
GREY / GRIS
GRAU / GRIS



TESTA DI MORO
DARK BROWN / BRUN
DUNKEL BRAUN / OSCURO

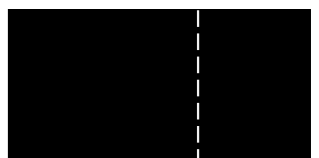

NERO
BLACK / NOIR
SCHWARZ / NEGRO

FENIX NTM®

Riparabilità termica dei micrografi superficiali
Thermal healing of superficial microscratches
Réparation thermique des micro-rayures superficielles
Thermische Bearbeitung von oberflächlichen Kratzern
Reparabilidad térmica de microarañazos superficiales

Morbidezza al tatto
Soft touch
Toucher soyeux
Weicher Touch
Suave al tacto

Resistenza al calore secco
Resistance to dry eat
Résistance à la chaleur sèche
Resistent gegen trockene Hitze
Resistencia al calor seco

Bassa riflessione della luce, superficie estremamente opaca
Low light reflectivity, extremely matt surface
Faible réflectivité, surface extrêmement mate
Geringe Lichtreflexion, extrem matte Oberfläche
Reflectancia mínima de la luz, superficie extremadamente mate

Anti-impronta
Anti-fingerprint
Aucune trace de doigts
Keine Fingerabdrücke
Anti-huella digital

Resistenza ai graffi e all'abrasione
Resistance to scratches and abrasion
Résistance aux rayures et à l'abrasion
Resisten gegen Kratzer und Abrieb
Resistencia a los arañazos y a la abrasion

Alta attività di abbattimento della carica batterica
Enhanced anti-bacterial properties
Propriétés antibactériennes renforcées
Verbesserte antibakterielle Eigenschaften
Propiedad anti-bacterias reforzada



BIANCO KOS 0032
WHITE KOS 0032 / BLANC KOS 0032
WEISS KOS 0032 / BLANCO KOS 0032



NERO INGO 0720
BLACK INGO 0720 / NOIR INGO 0720
SCHWARZ INGO 0720 / NEGRO INGO 0720



GRIGIO LONDRA 0718
GREY LONDRA 0718 / GRIS LONDRA 0718
GRAU LONDRA 0718 / GRIS LONDRA 0718

PROGRAMMA MODULARE DI CONTENITORI AD ANTE SCORREVOLI CONTRADDISTINTO DA NUMEROSE ALTEZZE E DA DUE PROFONDITÀ, DAL DESIGN ESSENZIALE, MATERIALI SELEZIONATI E ACCURATO STUDIO DEI PARTICOLARI.

MODULAR PROGRAMME OF SLIDING CABINETS CHARACTERIZED BY DIFFERENT HEIGHTS AND 2 DEPTHS, WITH PITHY DESIGN, REALIZED WITH WELL-SELECTED MATERIALS AND ACCURATE REGARD OF DETAILS.













FINITURE E COLORI

FINISHINGS AND COLORS / FINITIONS ET COULEURS / OBERFLACHE UND FARBEN / ACABADOS Y COLORES

STRUTTURA E ANTE NOBILITATO M1

STRUCTURE AND DOORS MELAMINE M1 / STRUCTURE, PORTES MELAMINE M1
KORPUSSE, TÜREN MELAMINE M1 / ESTRUCTURA, PUERTAS MELAMINE M1

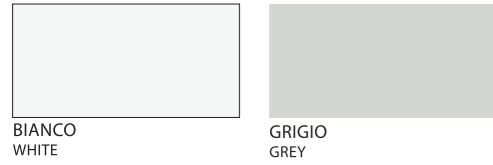

ANTE TOP E FIANCHI DI FINITURA NOBILITATO M2

DOORS, TOP AND FINISHING SIDE MELAMINE M2 / PORTES, TOP ET COTÉS DE FINITION MELAMINE M2
TÜREN, TOP UND ABSCHLUSSFLANKS MELAMINE M2 / PUERTAS, PLANO Y COSTADO DE CIERRE MELAMINE M2



STRUTTURA E ANTE NOBILITATO M3

STRUCTURE AND DOORS MELAMINE M3 / STRUCTURE, PORTES MELAMINE M3
KORPUSSE, TÜREN MELAMINE M3 / ESTRUCTURA, PUERTAS MELAMINE M3

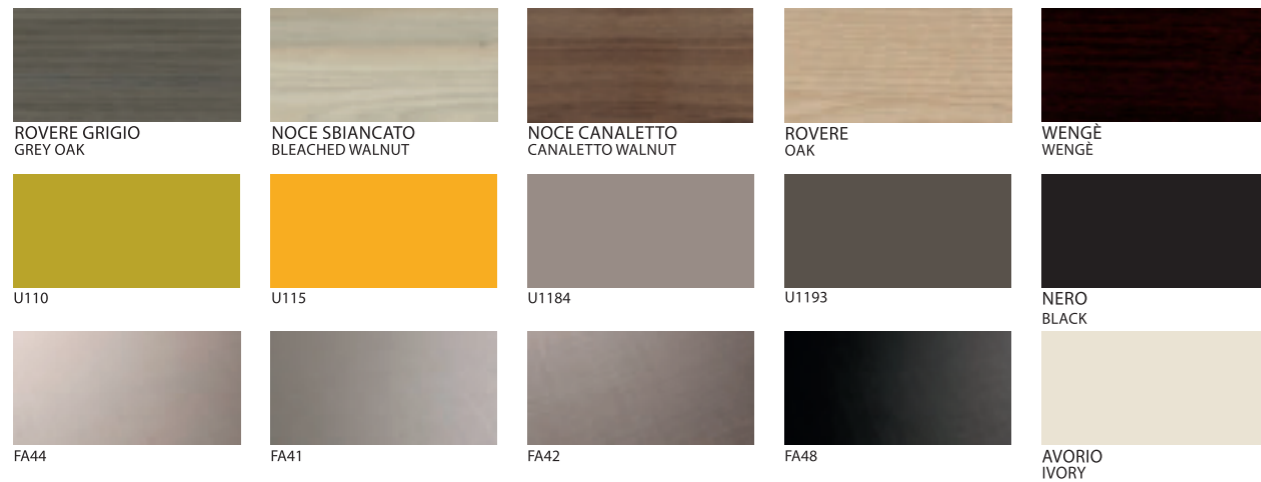

PIANO ESSENZA

WOOD TOP / PLATEAU BOIS / HOLZBRETT / PLAN MADERA

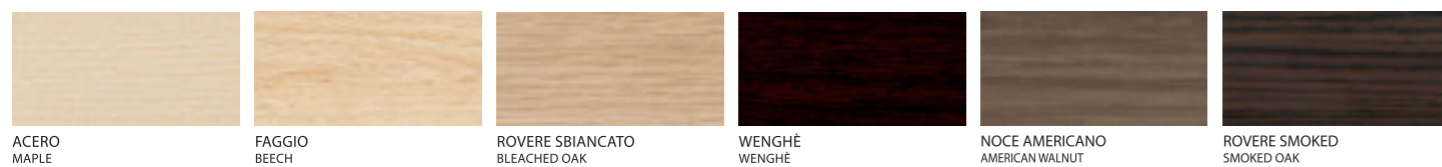

LACCATO OPACO LISCIO

LACQUERED OPAQUE SMOOTH / LAQUÉ OPAQUE LISSE / OPAKE LACKIERT / LACADO



LACCATO LUCIDO

GLOSSY LACQUERED / LAQUE BRILIANT / GLANZLACK / LACADO PULIDO



CUOIO

LEATHER / CUIR / LEDER / CUERO

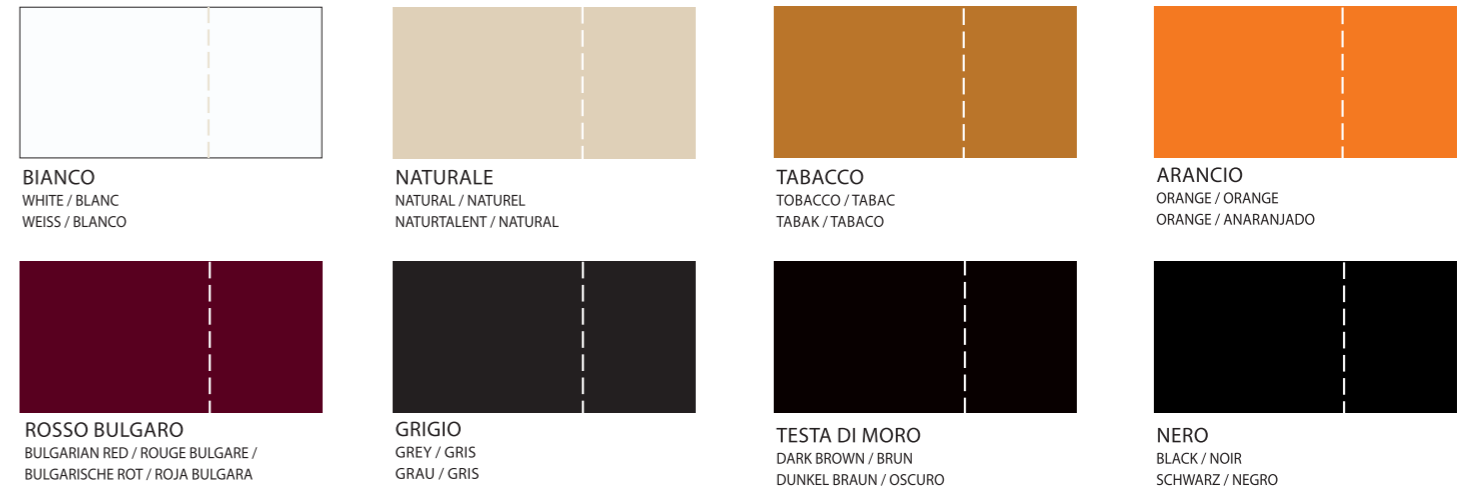

FENIX NTM[®]

- Riparabilità termica dei micrograffi superficiali
Thermal healing of superficial microscratches
Réparation thermique des micro-rayures superficielles
Thermische Bearbeitung von oberflächlichen Kratzern
Reparabilidad térmica de microarañazos superficiales
- Morbidezza al tatto
Soft touch
Toucher soyeux
Weicher Touch
Suave al tacto
- Resistenza al calore secco
Resistance to dry heat
Résistance à la chaleur sèche
Resistent gegen trockene Hitze
Resistencia al calor seco

- Bassa riflessione della luce, superficie estremamente opaca
Low light reflectivity, extremely matt surface
Faible réflectivité, surface extrêmement mate
Geringe Lichtreflexion, extrem matte Oberfläche
Reflectancia mínima de la luz, superficie extremadamente mate
- Anti-impronta
Anti-fingerprint
Aucune trace de doigts
Keine Fingerabdrücke
Anti-huella digital
- Resistenza ai graffi e all'abrasione
Resistance to scratches and abrasion
Résistance aux rayures et à l'abrasion
Resisten gegen Kratzer und Abrieb
Resistencia a los arañazos y a la abrasión
- Alta attività di abbattimento della carica batterica
Enhanced anti-bacterial properties
Propriétés antibactériennes renforcées
Verbesserte antibakterielle Eigenschaften
Propiedad anti-bacterias reforzada



BIANCO KOS 0032
WHITE KOS 0032 / BLANC KOS 0032
WEISS KOS 0032 / BLANCO KOS 0032

NERO INGO 0720
BLACK INGO 0720 / NOIR INGO 0720
SCHWARZ INGO 0720 / NEGRO INGO 0720

GRIGIO LONDRA 0718
GREY LONDRA 0718 / GRIS LONDRA 0718
GRAU LONDRA 0718 / GRIS LONDRA 0718

PROGRAMMA DI CONTENITORI SIA AD ANTE SCORREVOLI
CHE A BATTENTE ADATTO PER INSTALLAZIONI DI TESTA
ALLE SCRIVANIE SIA SINGOLE CHE BENCH.

PROGRAM OF STORAGE SLIDING AND HINGED DOORS
SUITABLE FOR HEAD INSTALLATION FOR SINGLE AND
BENCH DESK.





FINITURE E COLORI

FINISHINGS AND COLORS / FINITIONS ET COULEURS / OBERFLACHE UND FARBEN / ACABADOS Y COLORES

STRUTTURA E ANTE NOBILITATO M1

STRUCTURE AND DOORS MELAMINE M1 / STRUCTURE, PORTES MELAMINE M1

KORPUSSE, TÜREN MELAMINE M1 / ESTRUCTURA, PUERTAS MELAMINE M1



BIANCO
WHITE

GRIGIO
GREY

ANTE TOP E FIANCHI DI FINITURA NOBILITATO M2

DOORS, TOP AND FINISHING SIDE MELAMINE M2 / PORTES, TOP ET COTÉS DE FINITION MELAMINE M2

TÜREN, TOP UND ABSCHLUSSFLANKS MELAMINE M2 / PUERTAS, PLANO Y COSTADO DE CIERRE MELAMINE M2



ROVERE GRIGIO
GREY OAK

NOCE SBIANCATO
BLEACHED WALNUT

NOCE CANALETTO
CANALETTO WALNUT

ROVERE
OAK

WENGÉ
WENGÉ



U110



U115



U1184



U1193



NERO
BLACK



FA44



FA41



FA42



FA48

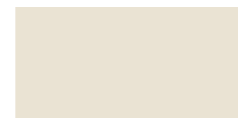

AVORIO
IVORY

STRUTTURA E ANTE NOBILITATO M3

STRUCTURE AND DOORS MELAMINE M3 / STRUCTURE, PORTES MELAMINE M3

KORPUSSE, TÜREN MELAMINE M3 / ESTRUCTURA, PUERTAS MELAMINE M3

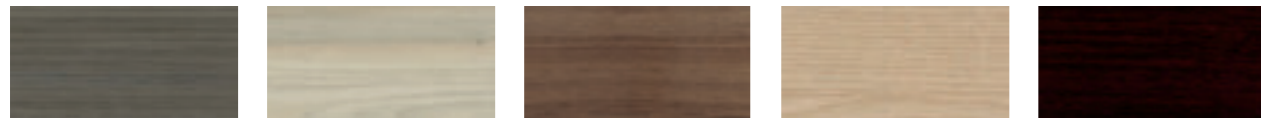

ROVERE GRIGIO
GREY OAK

NOCE SBIANCATO
BLEACHED WALNUT

NOCE CANALETTO
CANALETTO WALNUT

ROVERE
OAK

WENGÉ
WENGÉ



U110



U115



U1184



U1193



NERO
BLACK



FA44



FA41



FA42



FA48

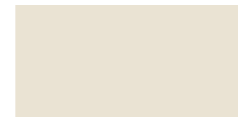

AVORIO
IVORY

FENIX NTM®

Riparabilità termica dei micrograffi superficiali
Thermal healing of superficial microscratches
Réparation thermique des micro-rayures superficielles
Thermische Bearbeitung von oberflächlichen Kratzern
Reparabilidad térmica de microarañazos superficiales

Morbidezza al tatto
Soft touch
Toucher soyeux
Weicher Touch
Suave al tacto

Resistenza al calore secco
Resistance to dry heat
Résistance à la chaleur sèche
Resistent gegen trockene Hitze
Resistencia al calor seco

Bassa riflessione della luce, superficie estremamente opaca
Low light reflectivity, extremely matt surface
Faible réflectivité, surface extrêmement mate
Geringe Lichtreflexion, extrem matte Oberfläche
Reflectancia mínima de la luz, superficie extremadamente mate

Anti-impronta
Anti-fingerprint
Aucune trace de doigts
Keine Fingerabdrücke
Anti-huella digital

Resistenza ai graffi e all'abrasione
Resistance to scratches and abrasion
Résistance aux rayures et à l'abrasion
Resistent gegen Kratzer und Abrieb
Resistencia a los arañazos y a la abrasion

Alta attività di abbattimento della carica batterica
Enhanced anti-bacterial properties
Propriétés antibactériennes renforcées
Verbesserte antibakterielle Eigenschaften
Propiedad anti-bacterias reforzada



BIANCO KOS 0032
WHITE KOS 0032 / BLANC KOS 0032
WEISS KOS 0032/ BLANCO KOS 0032



NERO INGO 0720
BLACK INGO 0720/ NOIR INGO 0720
SCHWARZ INGO 0720/ NEGRO INGO 0720



GRIGIO LONDRA 0718
GREY LONDRA 0718/ GRIS LONDRA 0718
GRAU LONDRA 0718 / GRIS LONDRA 0718





FINITURE E COLORI

FINISHINGS AND COLORS / FINITIONS ET COULEURS / OBERFLACHE UND FARBEN / ACABADOS Y COLORES

STRUTTURA NOBILITATO

STRUCTURE MELAMINE / STRUCTURE MELAMINE
KORPUSSE MELAMINE / ESTRUCTURA MELAMINE

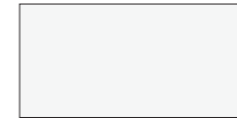

BIANCO
WHITE



NERO
BLACK

Arteco

To improve the technical and the qualitative characteristics of the production, Arteco reserves the right to make all the suitable modifications without previous notice.

Arteco, al fine di migliorare le caratteristiche tecniche e qualitative della sua produzione, si riserva di apportare, anche senza preavviso, tutte le modifiche che si rendessero necessarie.



