

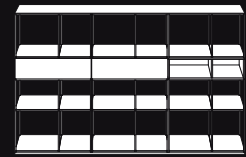

EXTENDO
DESIGN SOURCE

living systems



atelier

AT02 pg. 12
AT03 pg. 14
AT01 pg. 16
AT04 pg. 18
AT06 pg. 20
AT05 pg. 22

AT07 pg. 24
AT08 pg. 25

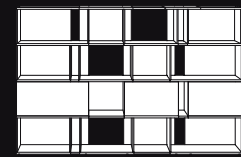

from>to

FT30 pg. 80
FT02 pg. 82
FT03 pg. 84
FT01 pg. 86
FT05A pg. 88
FT04 pg. 90



monolith

MN03 pg. 30
MN09 pg. 32
MN08 pg. 36
MN02C pg. 38
MN02B pg. 39
MN06A pg. 40

MN06B pg. 41
MN04 pg. 42
MN01 pg. 44
MN02A pg. 46
MN05 pg. 48

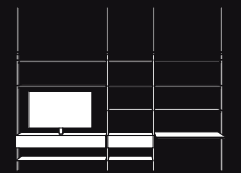

system

SY54 pg. 96
SY13 pg. 100
SY03 pg. 102
SY04 pg. 104
SY16 pg. 106
SY14 pg. 107

SY02 pg. 108
SY52 pg. 112
SY53 pg. 114

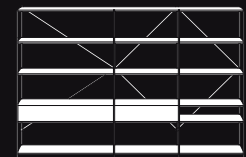

XY

XY30 pg. 54
XY31 pg. 58
XY29 pg. 60
XY28 pg. 64
XY02 pg. 66
XY10 pg. 68

XY08 pg. 69
XY09 pg. 70
XY03 pg. 72
XY15 pg. 74

tables and coffee tables



balance

BA08 pg. 120
BA02 pg. 122
BA03 pg. 123
BA01 pg. 124
BA04 pg. 126

BA06 pg. 128
BA05 pg. 130
BA07 pg. 132



spillo

SP24 pg. 136
SP21 pg. 138
SP05 pg. 140
SP20 pg. 141
SP25 pg. 142

SP03 pg. 144
SP19 pg. 145
SP22 pg. 146
SP04 pg. 148

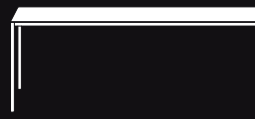

sintesi

ST01 pg. 154
ST02 pg. 156
ST06 pg. 158
ST03 pg. 162

ST04 pg. 166
ST05 pg. 167



T7

T701 pg. 170
T702 pg. 172



T8

T801 pg. 176
T803 pg. 178
T804 pg. 182
T802 pg. 184



IPE

IP01 pg. 188
IP03 pg. 190
IP02 pg. 192



danske T

DT01 pg. 196
DT02 pg. 198

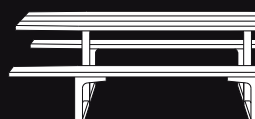

hammer

HA04 pg. 202
HA05 pg. 204
HA06 pg. 206

HA03 pg. 208
HA02 pg. 209



mr. hyde

MH28 pg. 212
MH29 pg. 214



spillo

SP26 pg. 150



déco

DE03 pg. 222
DE06 pg. 223
DE01 pg. 224
DE05 pg. 225

DE02 pg. 226
DE04 pg. 227



mr. hyde

MH01 pg. 216
MH07 pg. 217
MH02 pg. 218

seating



viking K

VK01 pg. 232



viking W

VK02 pg. 236



viking L

VK03 pg. 238



viking GL

VK04 pg. 240



danske C1

DC01 pg. 246



danske C2

DC02 pg. 248



danske C3

DC04 pg. 252
DC03 pg. 254

multimedia

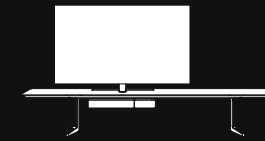

connect

CN01 pg. 260
CN02 pg. 264

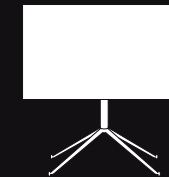

apollo

AP01 pg. 268

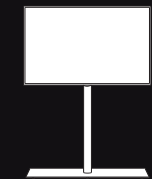

spin360

SN01 pg. 274

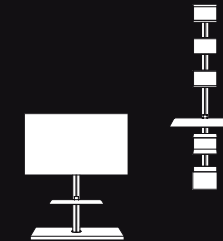

girogiro-system

SY55 pg. 280
SY20C pg. 282
SY23 pg. 284
SY18 pg. 286
SY17 pg. 287

walk in closet

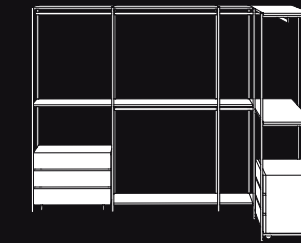

slide

SL01 pg. 294
SL04 pg. 298
SL03 pg. 302
SL02 pg. 304

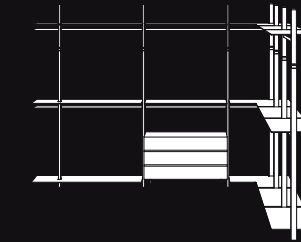

personal

PE01 pg. 310
PE02 pg. 314
PE03 pg. 318
PE04 pg. 322
PE05 pg. 324
PE06 pg. 326
PE07 pg. 328
PE08 pg. 332
PE09 pg. 334

living systems

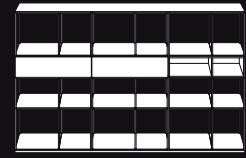

atelier

pg. 08

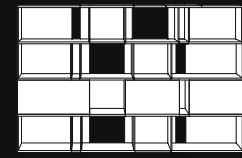

from>to

pg. 76



monolith

pg. 26

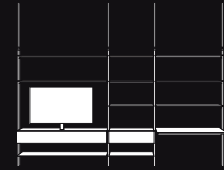

system

pg. 92

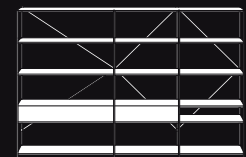

XY

pg. 50



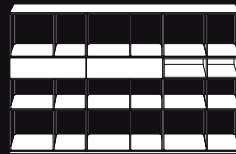

atelier

Atelier è configurabile utilizzando moduli in acciaio con sezione minima di 10x10mm e contenitori in legno con diverse tipologie di aperture. Telai e contenitori possono essere sovrapposti e affiancati a piacimento, posizionati su basi o sospesi a parete. Sono disponibili accessori da inserire all'interno dei telai e top in HPL o marmo.

Atelier can be configured using modular elements in steel with a minimum 10x10mm cross-section as well as wooden containers with several different types of openings. Both frames and containers can be stacked and placed side by side as desired, either installed onto support bases or wall-mounted. Accessories to be integrated into the HPL or marble frames and tops.

Atelier peut être configuré en utilisant des modules en acier avec une section minimum de 10x10 mm et des bacs en bois avec plusieurs typologies d'ouvertures. Châssis et bacs peuvent être superposés et associés à loisir, positionnés sur des bases ou suspendus au mur. Des accessoires sont disponibles pour l'insertion à l'intérieur des châssis et plateau en HPL ou marbre.

Bei der modularen Serie Atelier lassen sich Stahlmodule mit einer Mindeststärke von 10x10 mm mit Holzbehältern verschiedener Arten und Öffnungen kombinieren. Gestelle und Behälter können übereinander oder nebeneinander angeordnet, auf einen Unterbau gestellt oder an der Wand aufgehängt werden. Verschiedene Einsätze für die Gestelle sowie Abschlussplatten aus HPL oder Marmor als Zubehör erhältlich.

Atelier se puede configurar utilizando módulos de acero con sección mínima de 10x10mm, así como contenedores de madera con distintos tipos de aperturas. Bastidores y contenedores, pueden colocarse uno encima del otro o uno al lado del otro, según se prefiera, posicionados sobre bases o colgados en la pared. Están disponibles accesorios que se pueden introducir en el interior de los bastidores y encimeras de laminado de alta presión (HPL) o mármol.



materiali / materials

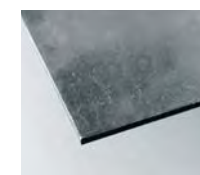

acciaio
steel
acier
Stahl
acero



HPL

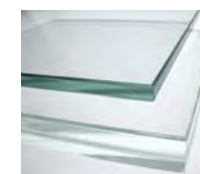

vetro
glass
verre
Glas
cristal

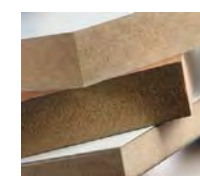

MDF
DM



Le materie prime che costituiscono il sistema atelier derivano da un processo di riutilizzo e sono a loro volta riciclabili.

The primary materials used in the system atelier are sourced from a reuse process, and are in turn recyclable.

Les matières premières qui composent le système atelier dérivent d'un processus de réutilisation et sont à leur tour recyclables.

Die Rohstoffe für das System atelier entstammen einem Wiederverwertungsprozess und sind Ihrerseits wiederum recyclebar.

Las materias primas que constituyen el sistema atelier proceden de un proceso de reutilización y son, a su vez, reciclables.



finiture / finishes

telaio / structure / châssis / Gestell / bastidor

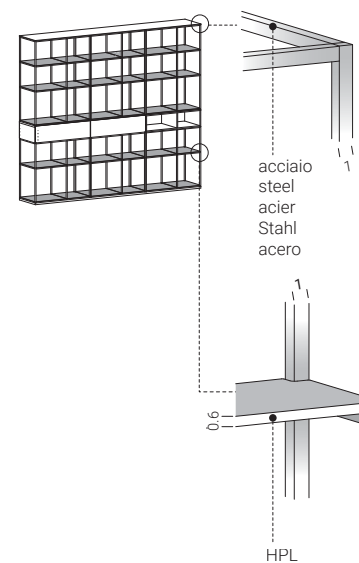

verniciatura a polveri
powder coating
peinture en poudres
Pulverlackierung
pintura en polvo

	C12 bianco white		C08 nero black
	C21 seta silk		C29 bronzo bronze
	C23 corda ecru		
	C30 ghisa cast-iron		
	C14 antracite anthracite		

laccato lacquered
laqué
lackiert
lacado

	Q05 bianco white		Q04 nero black
	Q16 seta silk		Q21 bronzo bronze
	Q17 corda ecru		
	Q20 ghisa cast-iron		
	Q14 antracite anthracite		

essenze woods bois Holzes maderas		Y37 rovere affumicato smoked oak
		Y38 rovere nero black oak

contenitori / cabinets / modules de rangement / Behälter / contenedores

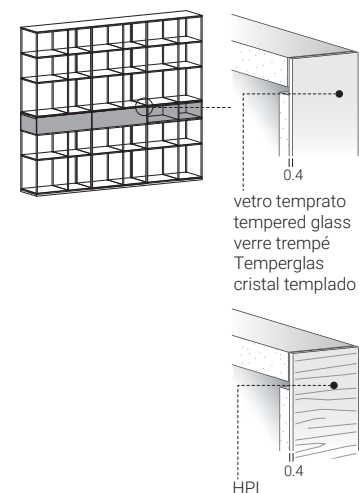

laccato lacquered
laqué
lackiert
lacado

	Q05 bianco white		Q04 nero black
	Q16 seta silk		Q21 bronzo bronze
	Q17 corda ecru		
	Q20 ghisa cast-iron		
	Q14 antracite anthracite		

essenze woods
bois
Holzes
maderas

	Y37 rovere affumicato smoked oak
	Y38 rovere nero black oak

dimensioni / dimensions

telaio / structure / châssis / Gestell / bastidor

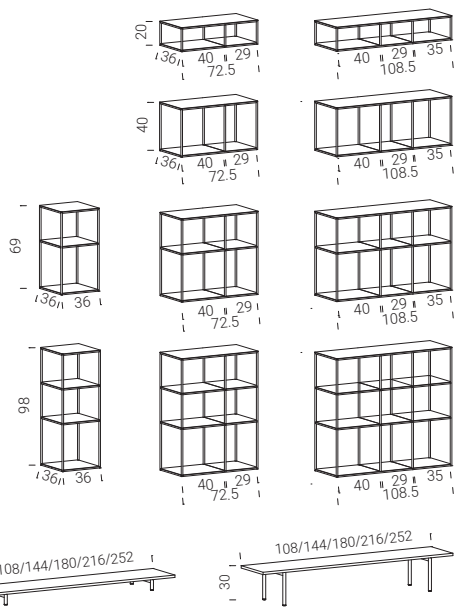

contenitori / cabinets / modules de rangement / Behälter / contenedores

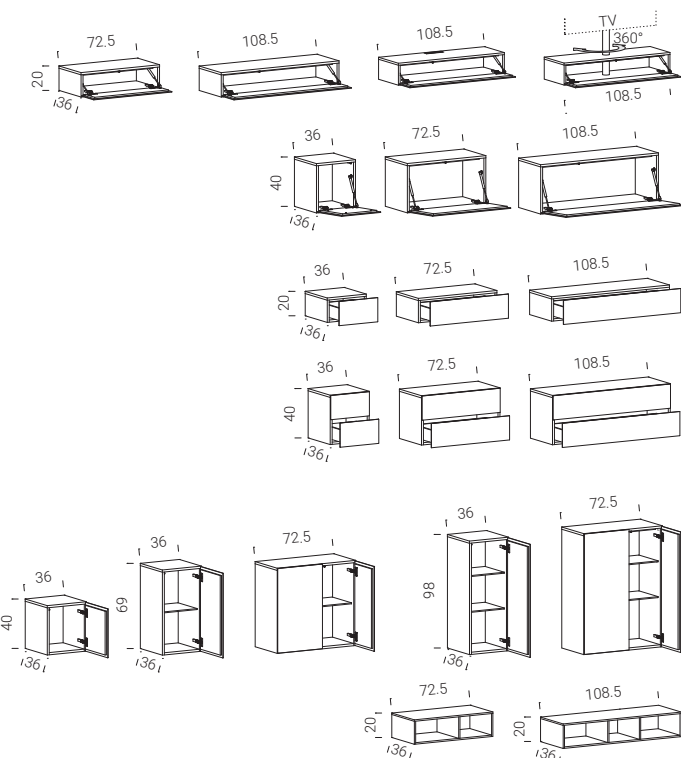

finiture / finishes

moduli interni / internal modules / modules internes / interne Module / módulos internos

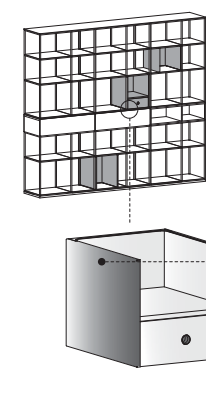

A verniciatura a polveri
powder coating
peinture en poudres
Pulverlackierung
pintura en polvo

	C12 bianco white		C08 nero black
	C21 seta silk		C29 bronzo bronze
	C23 corda ecru		
	C30 ghisa cast-iron		
	C14 antracite anthracite		
	C08 nero black		
	C29 bronzo bronze		

B laccato lacquered
laqué
lackiert
lacado

	Q05 bianco white		Q04 nero black
	Q16 seta silk		Q21 bronzo bronze
	Q17 corda ecru		
	Q20 ghisa cast-iron		
	Q14 antracite anthracite		
	Q04 nero black		
	Q21 bronzo bronze		

essenze woods bois Holzes maderas		Y37 rovere affumicato smoked oak
		Y38 rovere nero black oak

piano / top / plateau / platte / sobre

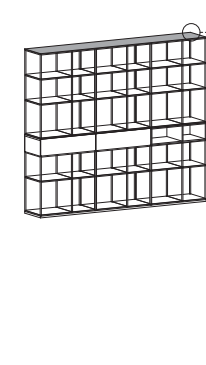

marmo/marble
marbre/Marmor
mármol

	Z01 bianco Carrara white Carrara		Z02 nero Marquiña black Marquiña
	L03 bianco white		
	L08 grigio Londra London grey		
	L06 nero black		

laccato lacquered
laqué
lackiert
lacado

	Q05 bianco white		Q16 seta silk
	Q17 corda ecru		Q20 ghisa cast-iron
	Q14 antracite anthracite		Q04 nero black
	Q21 bronzo bronze		

essenze woods
bois
Holzes
maderas

	Y37 rovere affumicato smoked oak
	Y38 rovere nero black oak

ripiani / shelves / étagères / Böden / estantes

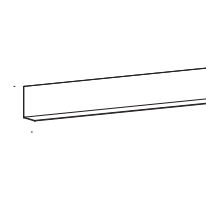

laccato lacquered
laqué
lackiert
lacado

	Q05 bianco white		Q16 seta silk
	Q17 corda ecru		Q20 ghisa cast-iron
	Q14 antracite anthracite		Q04 nero black
	Q21 bronzo bronze		

essenze woods
bois
Holzes
maderas

	Y36 rovere oak
	Y34 noce walnut
	Y37 rovere affumicato smoked oak
	Y38 rovere nero black oak

dimensioni / dimensions

moduli interni / internal modules / modules internes / interne Module / módulos internos

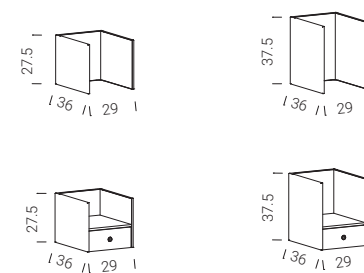

piano / top / plateau / platte / sobre

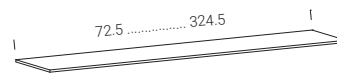

ripiani / shelves / étagères / Böden / estantes

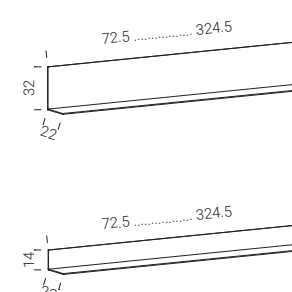

disponibili riduzioni a misura / tailor-made reduction available / disponibles réductions sur mesure
cm Verkleinerung nach Kundenwunsch / disponibles reducciones a medida



atelier
AT02

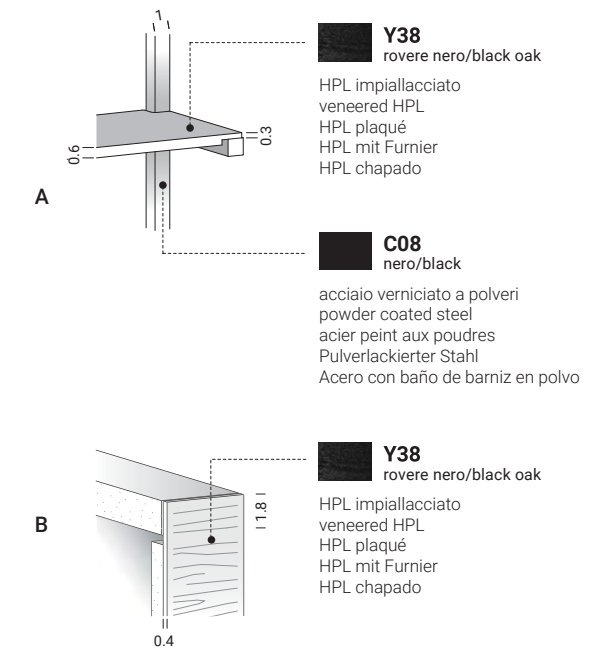
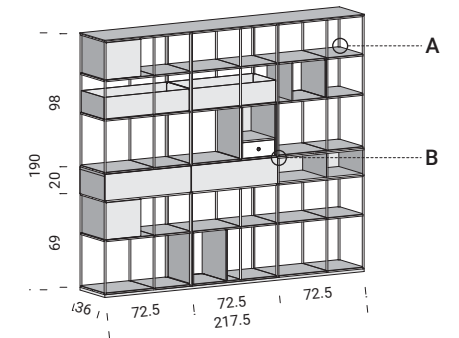

collection info
pg. 08



atelier
AT03

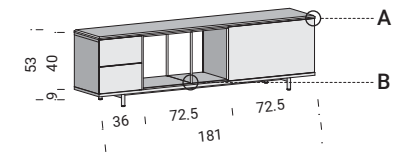

Z02
nero Marquiña/black Marquiña

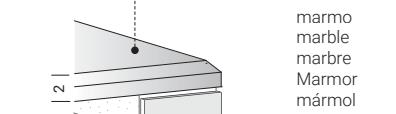

marmo
marble
marbre
Marmor
mármol

Q14
antracite/anthracite

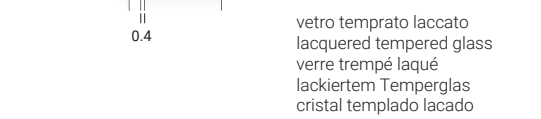

vetro temprato laccato
lacquered tempered glass
verre trempé laqué
lackiertem Temperglas
cristal templado lacado

Y37
rovere affumicato/smoked oak

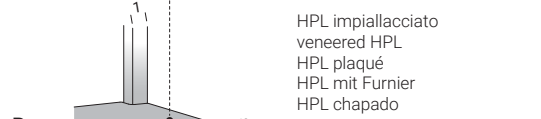

HPL impiallacciato
veneered HPL
HPL plaqué
HPL mit Furnier
HPL chapado

C14
antracite/anthracite

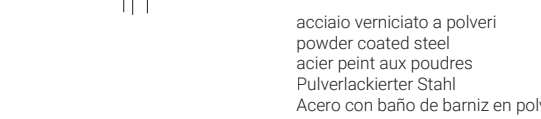

acciaio verniciato a polveri
powder coated steel
acier peint aux poudres
Pulverlackierter Stahl
Acero con baño de barniz en polvo

collection info
pg. 08



atelier
AT01

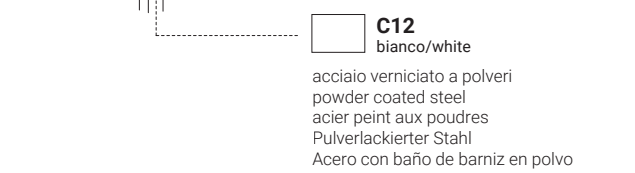
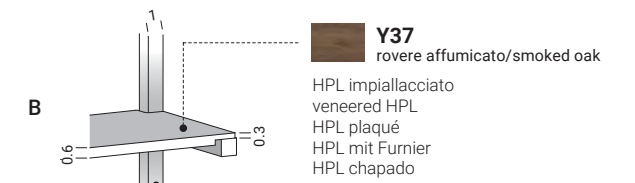
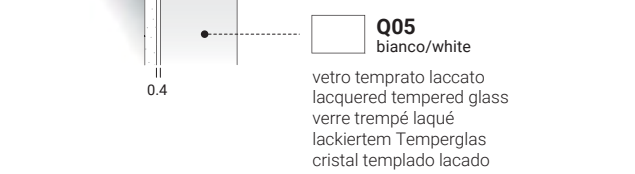
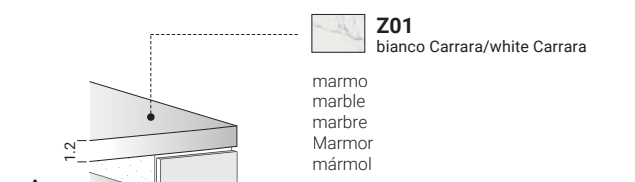
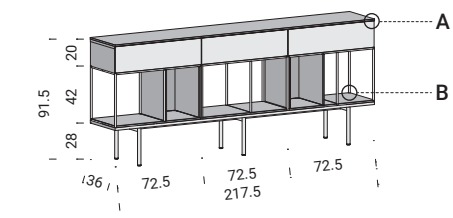

- Z01**
bianco Carrara/white Carrara
marmo
marble
marbre
Marmor
mármol
- Q05**
bianco/white
vetro temprato laccato
lacquered tempered glass
verre trempé laqué
lackiertem Temperglas
cristal templado lacado
- Y37**
rovere affumicato/smoked oak
HPL impiallacciato
veneered HPL
HPL plaqué
HPL mit Furnier
HPL chapado
- C12**
bianco/white
acciaio verniciato a polveri
powder coated steel
acier peint aux poudres
Pulverlackierter Stahl
Acero con baño de barniz en polvo

collection info
pg. 08



atelier
AT04

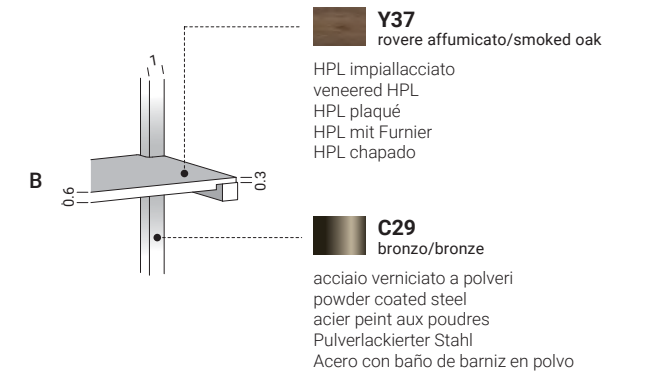
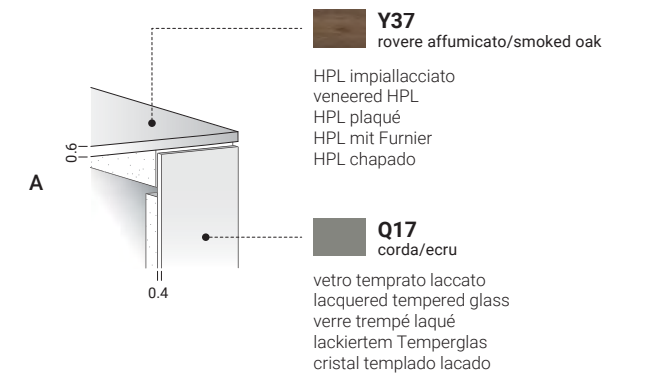
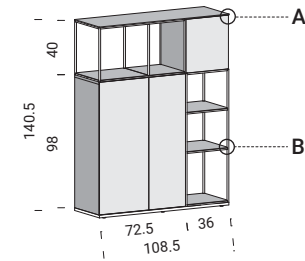

collection info
pg. 08



atelier
AT06

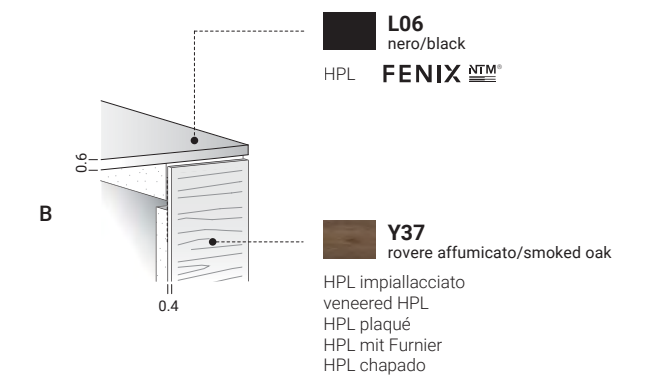
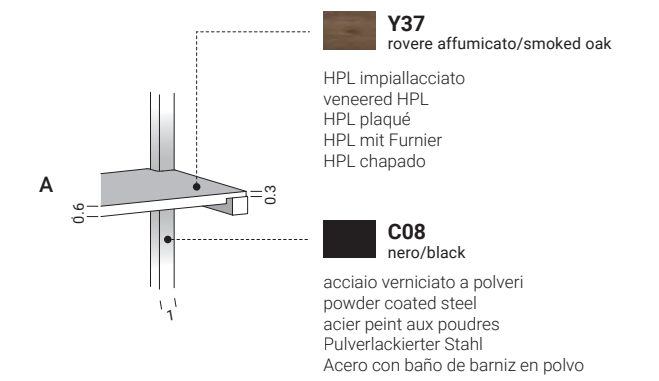
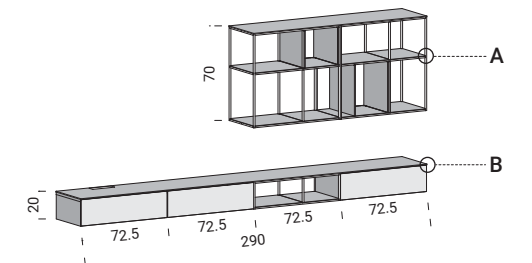

collection info
pg. 08



atelier
AT05

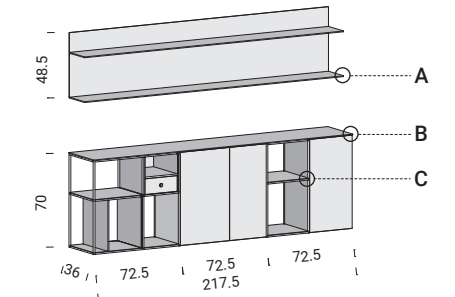

- A** 0.6
- Y37**
rovere affumicato/smoked oak
HPL impiallacciato
veneered HPL
HPL plaqué
HPL mit Furnier
HPL chapado
- B** 11.8 | 0.4
- Q14**
antracite/anthracite
vetro temprato laccato
lacquered tempered glass
verre trempé laqué
lackiertem Temperglas
cristal templado lacado
- C** 0.6 | 0.3
- Q14**
antracite/anthracite
HPL laccato
lacquered HPL
HPL laqué
HPL lackiert
HPL lacado
- C14**
antracite/anthracite
acciaio verniciato a polveri
powder coated steel
acier peint aux poudres
Pulverlackierter Stahl
Acero con baño de barniz en polvo

collection info
pg. 08



atelier
AT07

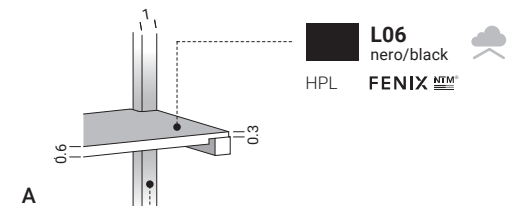
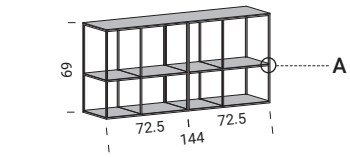

L06
nero/black

HPL **FENIX**

A

C08
nero/black

acciaio verniciato a polveri
powder coated steel
acier peint aux poudres
Pulverlackierter Stahl
Acero con baño de barniz en polvo

collection info
pg. 08



atelier
AT08

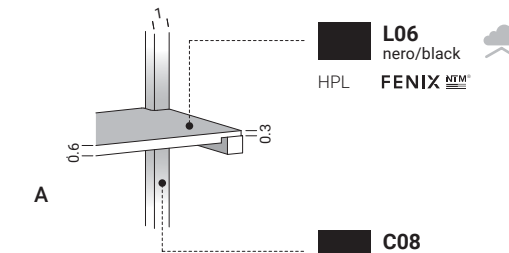
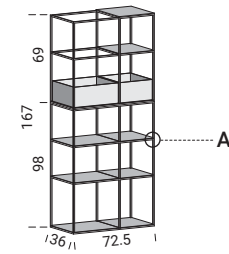

L06
nero/black

HPL **FENIX**

A

C08
nero/black

acciaio verniciato a polveri
powder coated steel
acier peint aux poudres
Pulverlackierter Stahl
Acero con baño de barniz en polvo

collection info
pg. 08



monolith

La scocca in alluminio estruso che costituisce l'ossatura portante di monolith, consente grande rigidità strutturale e una libera configurazione delle partizioni interne. Tale sistema costruttivo forma un insieme molto semplice da assemblare e riconfigurare, evitando di raddoppiare gli spessori dei fianchi al suo interno.

The frame in extruded aluminium forming the support structure of Monolith gives an extremely firm structure with free configuration of the inner partitions. This composition system forms a very simple set to assemble and re-configure, without doubling the thicknesses of its inner sides.

Le châssis en aluminium extrudé qui constitue l'ossature portante de monolith, permet une grande rigidité structurelle et une libre configuration des divisions internes. Ce système de construction forme un ensemble très simple à assembler et reconfigurer, en évitant de doubler les épaisseurs des côtés à l'intérieur.

Der Aufbau aus extrudiertem Aluminium, der das tragenden Gerüst des monolith darstellt, bietet eine bedeutende, strukturelle Steifheit und eine freie Konfiguration der Innenaufteilung. Dieses Konstruktionssystem bildet eine Einheit, die einfach zusammenzubauen und neu zu gestalten ist, wobei die Verdoppelung der Stärke der Seiten im Innenbereich vermieden wird.

El bastidor de aluminio extruido que constituye el armazón de soporte de Monolith permite una gran resistencia estructural y una libre configuración de las particiones interiores. Este sistema de construcción forma un conjunto muy fácil de montar y reconfigurar, evitando duplicar el espesor de los laterales en su interior.

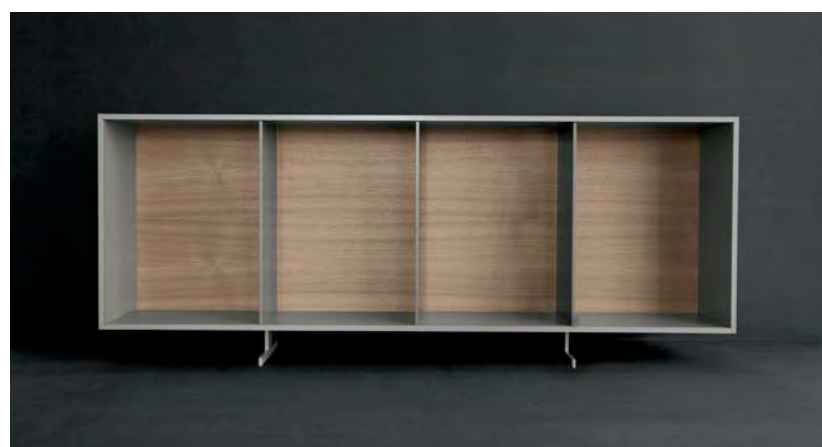
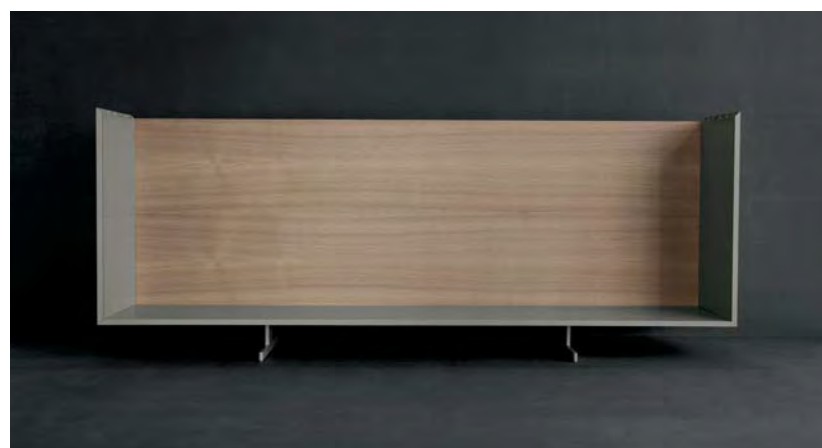

materiali / materials



alluminio
aluminium
Aluminium
aluminio

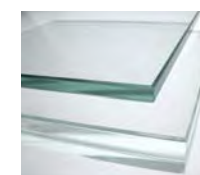

vetro
glass
verre
Glas
cristal



MDF
DM

Le materie prime che costituiscono il sistema monolith derivano da un processo di riutilizzo e sono a loro volta riciclabili.

The primary materials used in the system monolith are sourced from a reuse process, and are in turn recyclable.

Les matières premières qui composent le système monolith dérivent d'un processus de réutilisation et sont à leur tour recyclables.

Die Rohstoffe für das System monolith entstammen einem Wiederverwertungsprozess und sind ihrerseits wiederum recyclebar.

Las materias primas que constituyen el sistema monolith proceden de un proceso de reutilización y son, a su vez, reciclables.

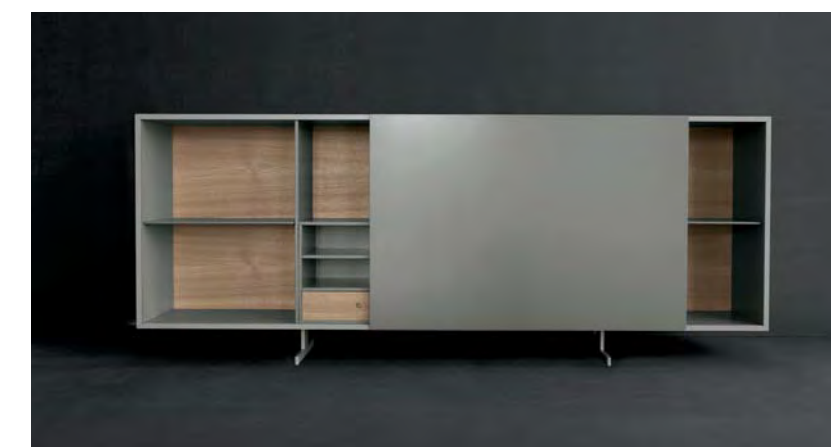
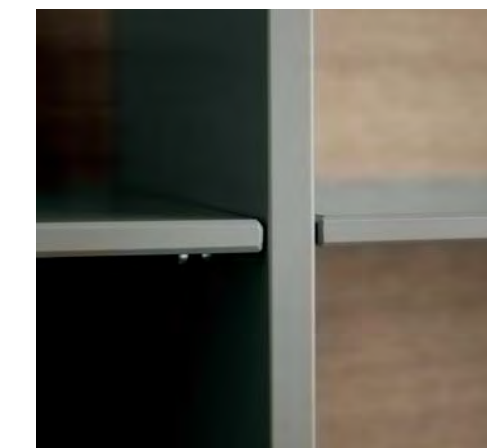

scoche / shells / cadres / Gehäuse / estructuras

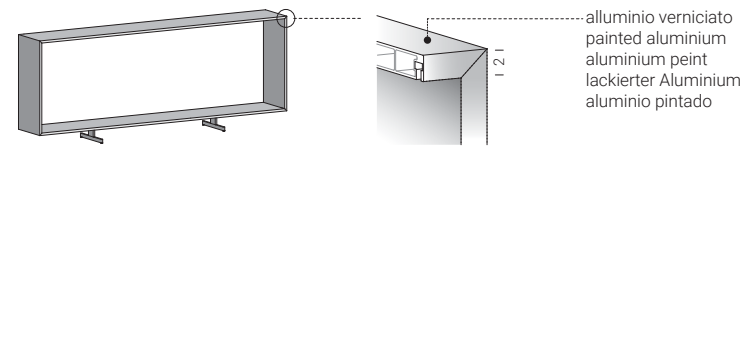

alluminio verniciato
painted aluminium
aluminium peint
lackierter Aluminium
aluminio pintado

- C12** bianco white
- C21** seta silk
- C23** corda ecru
- C30** ghisa cast-iron
- C14** antracite anthracite
- C08** nero black
- C29** bronzo bronze

fianchi interni / inner sides / côtés internes / Innenseiten / paredes interiores

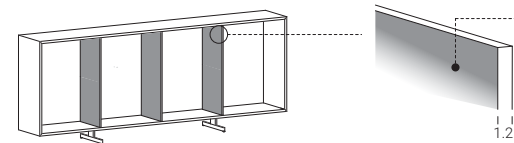

MDF laccato
lacquered MDF
MDF laqué
lackiertem MDF
DM lacado

- Q05** bianco white
- Q16** seta silk
- Q17** corda ecru
- Q20** ghisa cast-iron
- Q14** antracite anthracite
- Q04** nero black
- Q21** bronzo bronze

ripiani interni / inner shelving / étagères internes / Innenböden / estantes interiores

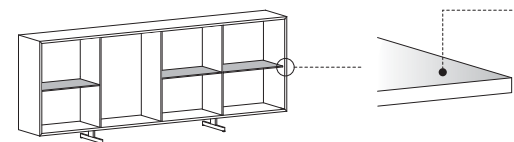

vetro laccato
lacquered glass
verre laqué
lackiertem Glas
cristal lacado

- V01** bianco white
- V15** seta silk
- V16** corda ecru
- V23** ghisa cast-iron
- V12** antracite anthracite
- V02** nero black
- V24** bronzo bronze
- V07** float
- V06** fumè smoked glass

schiene / backs / dos / Rückwände / traseras

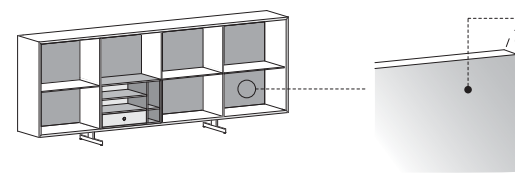

MDF laccato
lacquered MDF
MDF laqué
lackiertem MDF
DM lacado

- Q05** bianco white
- Q16** seta silk
- Q17** corda ecru
- Q20** ghisa cast-iron
- Q14** antracite anthracite
- Q04** nero black
- Q21** bronzo bronze

essenze
woods
bois
Holzes
maderas

- Y36** rovere oak
- Y35** noce walnut

frontali / doors fronts / faces des portes / Fronten der Türen / frontales de las puertas

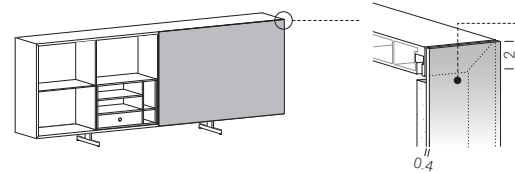

vetro laccato
lacquered glass
verre laqué
lackiertem Glas
cristal lacado

- V01** bianco white
- V15** seta silk
- V16** corda ecru
- V23** ghisa cast-iron
- V12** antracite anthracite
- V02** nero black
- V24** bronzo bronze
- V06** fumè smoked glass

top

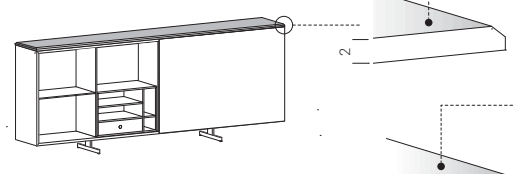

marmo
marble
marbre
Marmor
mármol

- Z01** bianco Carrara white Carrara
- Z02** nero Marquina black Marquina

HPL

- FENIX NTM** **L03** bianco white
- FENIX NTM** **L08** grigio Londra London grey
- FENIX NTM** **L06** nero black

essenze
woods
bois
Holzes
maderas

- Y36** rovere oak
- Y34** noce walnut
- Y37** rovere affumicato smoked oak
- Y39** frassino nero black ash

H1

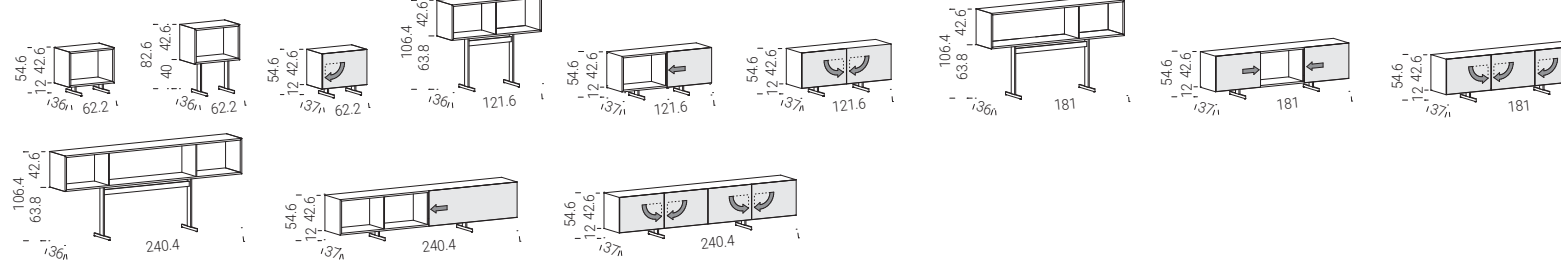

H2

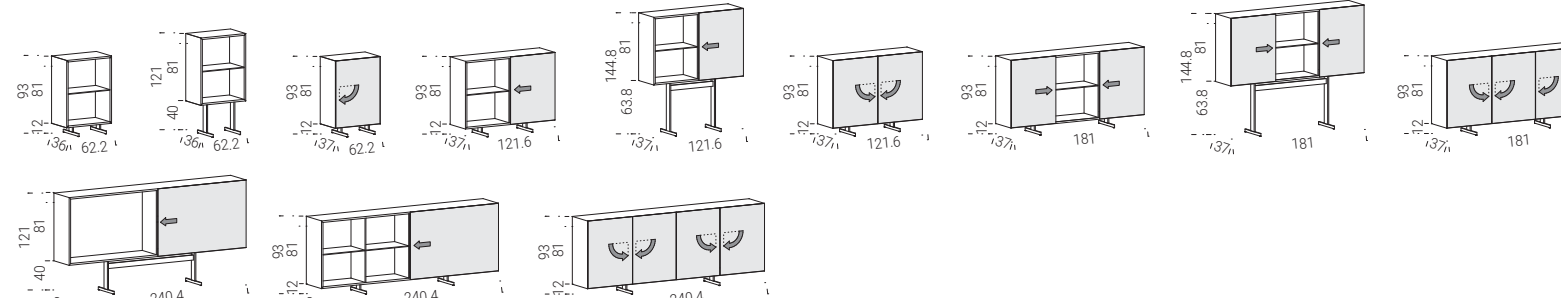

H3

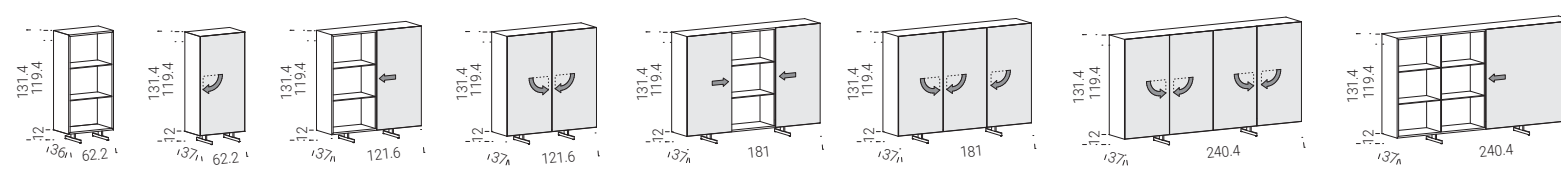

H4

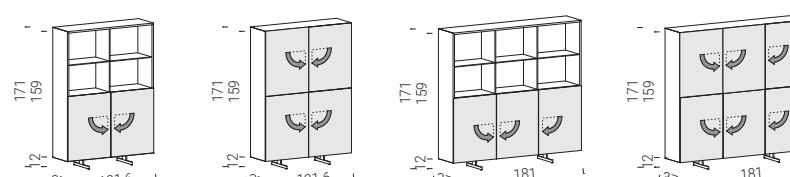

H5

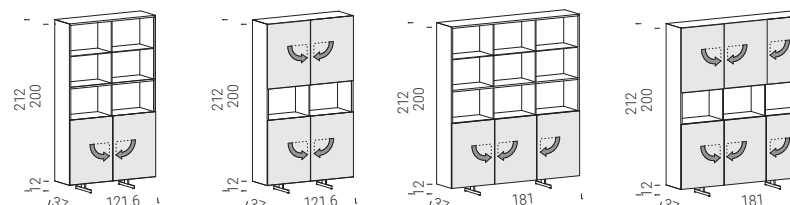

accessori / accessories / accessoires
Zubehör / accesorios

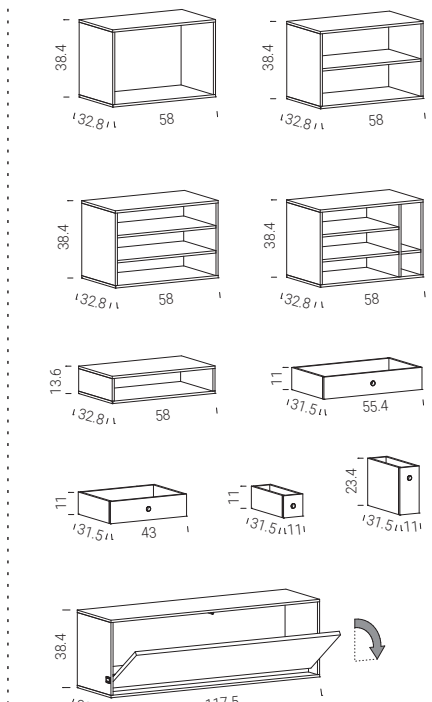

basi / bases / bases / Basis / bases

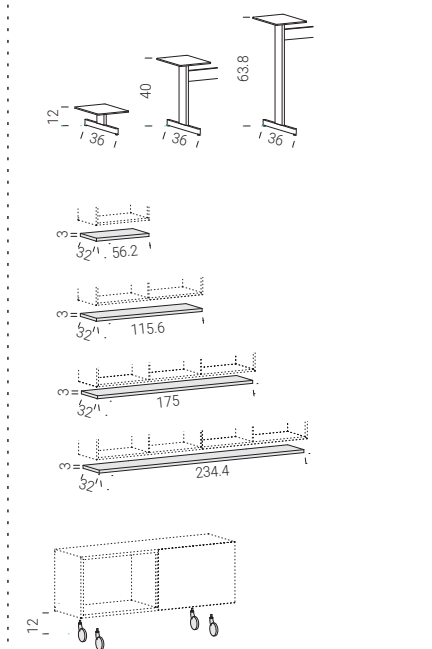

disponibili a listino ulteriori composizioni / further compositions available per pricelist / autres compositions disponibles sur la liste de prix / nach Preisliste stehen weitere Zusammenstellungen zur Verfügung / otras composiciones disponibles en la lista de precios



monolith
MN03

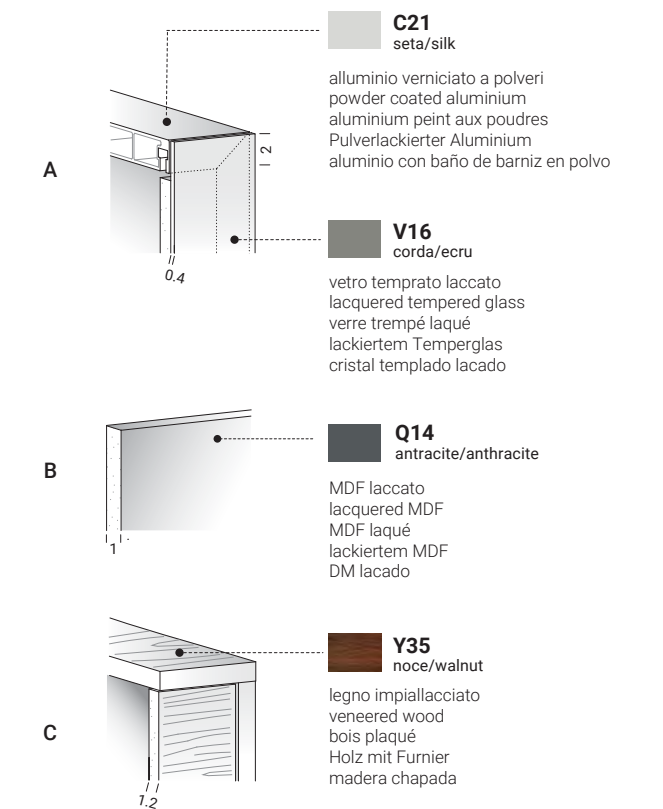
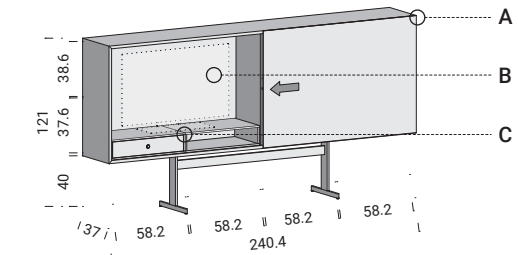

collection info
pg. 26



monolith
MN09

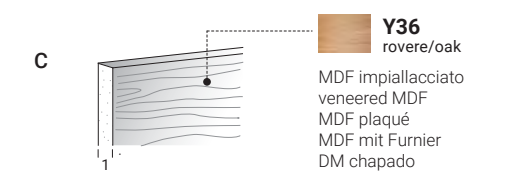
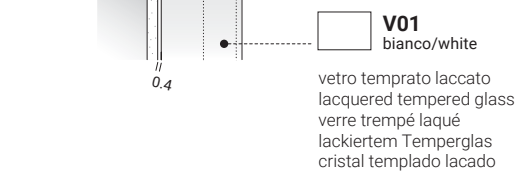
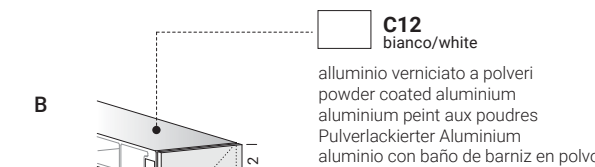
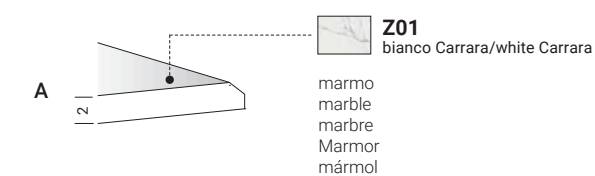
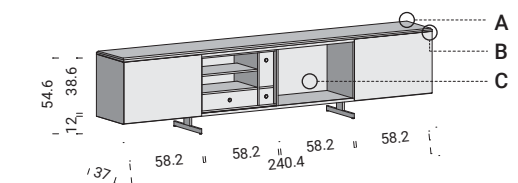

collection info
pg. 26





monolith
MN08

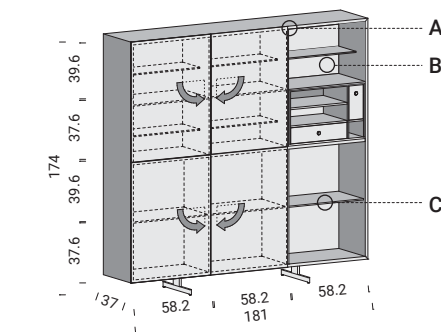

C23
corda/ecru

alluminio verniciato a polveri
powder coated aluminium
aluminium peint aux poudres
Pulverlackierter Aluminium
aluminio con baño de barniz en polvo

A

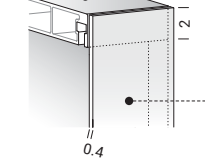

V06
fumé/smoked glass

vetro temprato
tempered glass
verre trempé
Temperglas
cristal templado

B

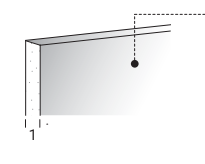

Q17
corda/ecru

MDF laccato
lacquered MDF
MDF laqué
lackiertem MDF
DM lacado

C

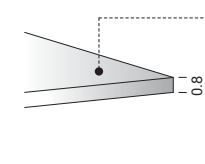

V16
corda/ecru

vetro temprato laccato
lacquered tempered glass
verre trempé laqué
lackiertem Temperglas
cristal templado lacado



monolith
MN02C

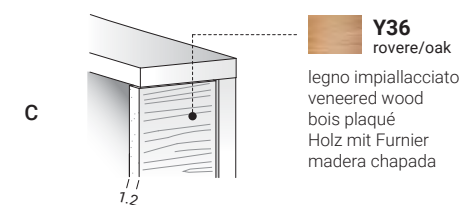
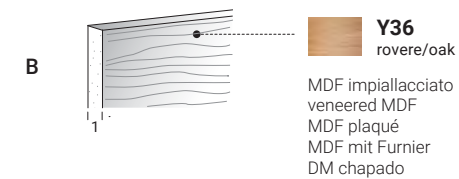
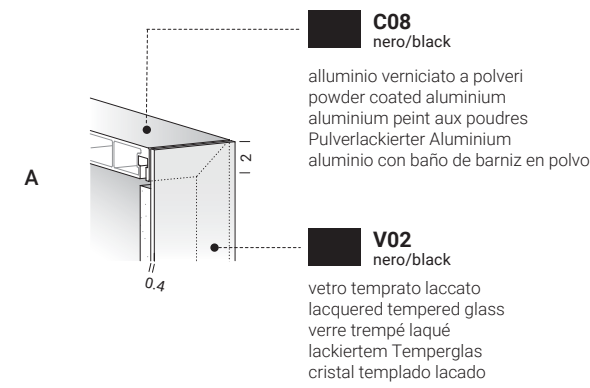
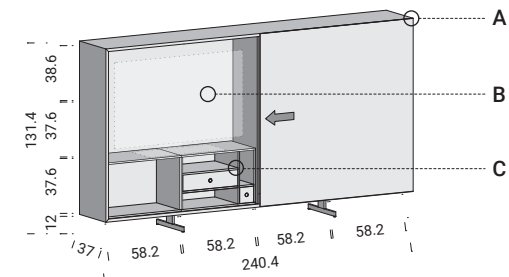

collection info
pg. 26

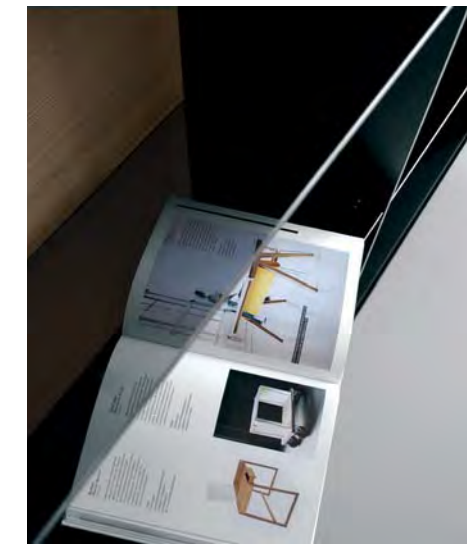

monolith
MN02B

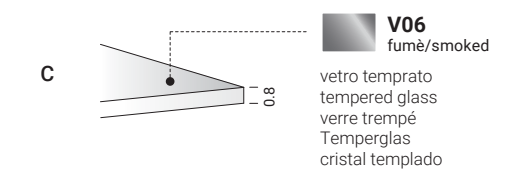
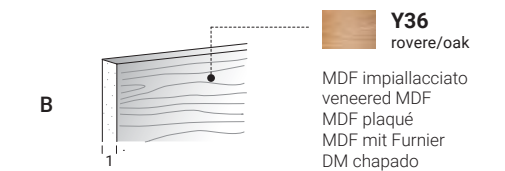
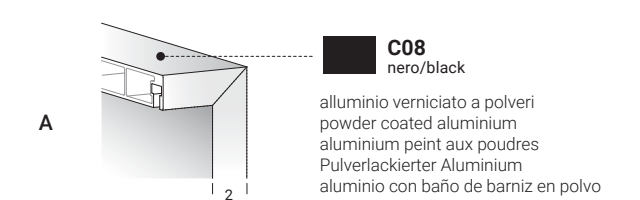
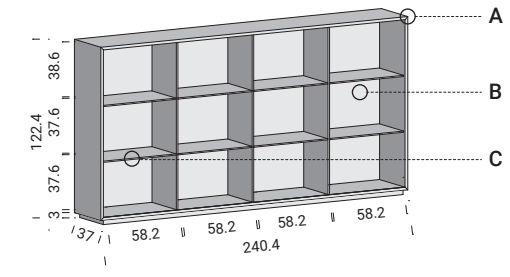

collection info
pg. 26

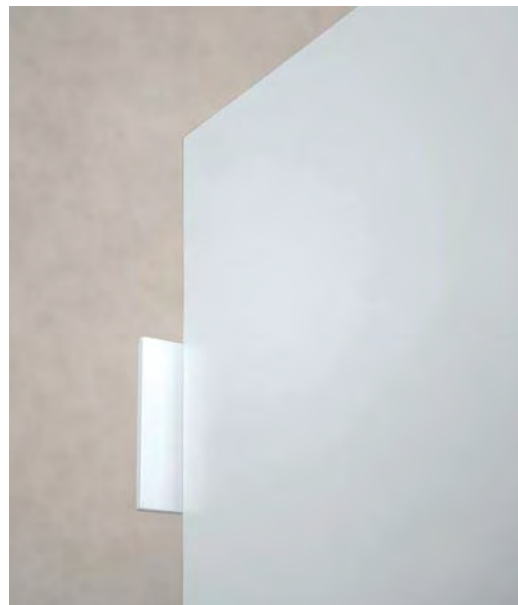

monolith
MN06A

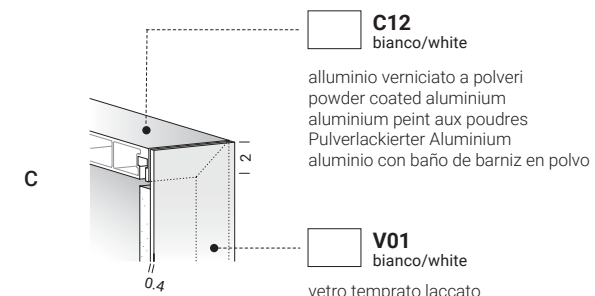
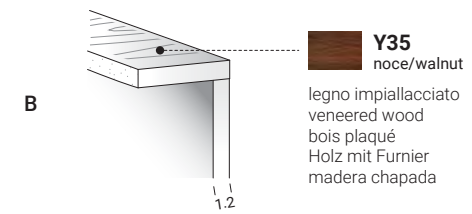
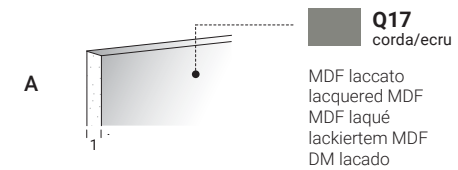
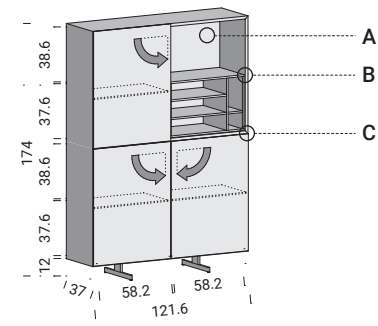

collection info
pg. 26



monolith
MN06B

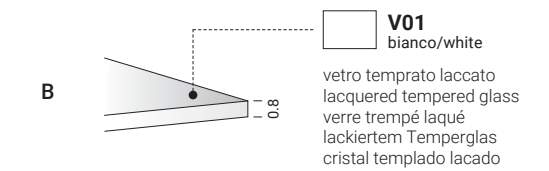
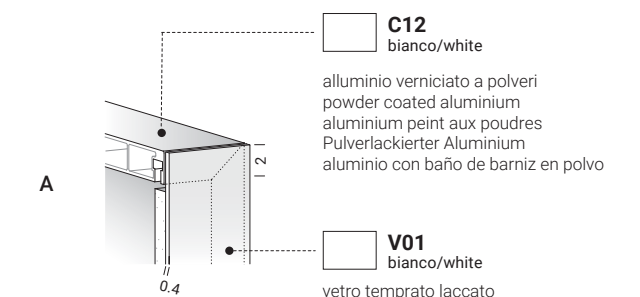
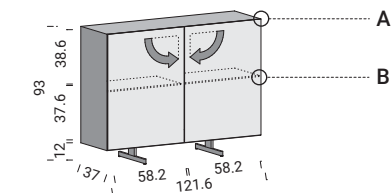

collection info
pg. 26



monolith MN04

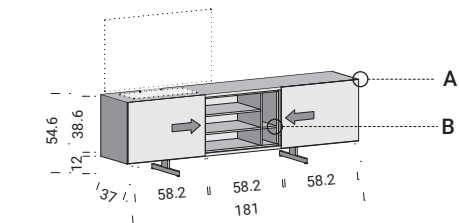

C14
antracite/anthracite
alluminio verniciato a polveri
powder coated aluminium
aluminium peint aux poudres
Pulverlackierter Aluminium
aluminio con baño de barniz en polvo

V12
antracite/anthracite
vetro temprato laccato
lacquered tempered glass
verre trempé laqué
lackiertem Temperglas
cristal templado lacado

Y35
noce/walnut
legno impiallacciato
veneered wood
bois plaqué
Holz mit Furnier
madera chapada

collection info
pg. 26



monolith
MN01

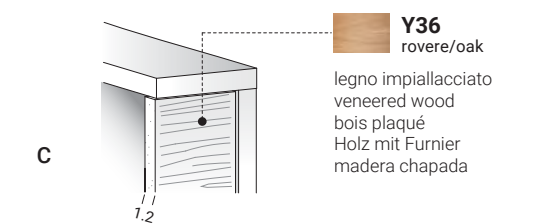
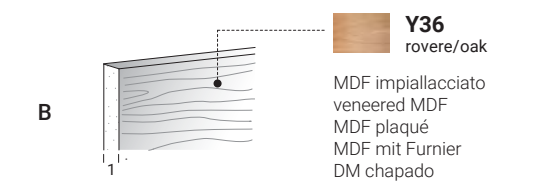
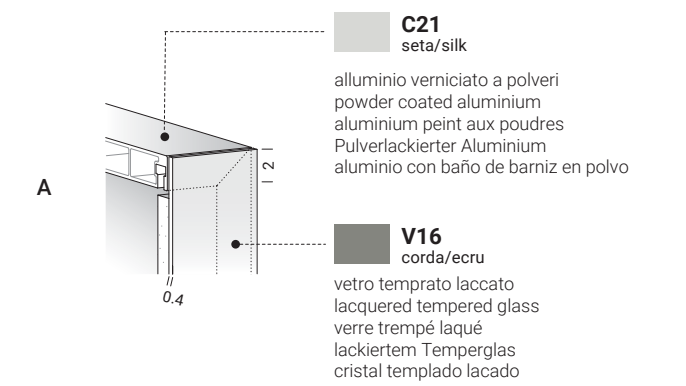
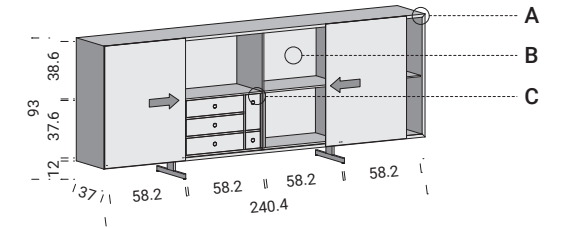

collection info
pg. 26



monolith
MN02A

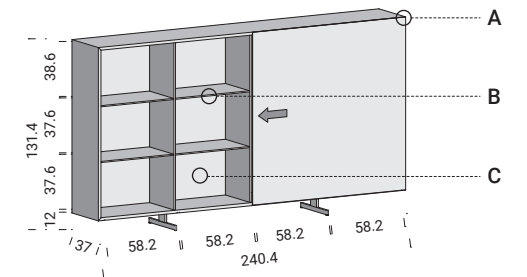

- C08**
nero/black
alluminio verniciato a polveri
powder coated aluminium
aluminium peint aux poudres
Pulverlackierter Aluminium
aluminio con baño de barniz en polvo
- V02**
nero/black
vetro temprato laccato
lacquered tempered glass
verre trempé laqué
lackiertem Temperglas
cristal templado lacado
- V06**
fumè/smoked
vetro temprato
tempered glass
verre trempé
Temperglas
cristal templado
- Y36**
rovere/oak
MDF impiallacciato
veneered MDF
MDF plaqué
MDF mit Furnier
DM chapado

collection info
pg. 26



monolith
MN05

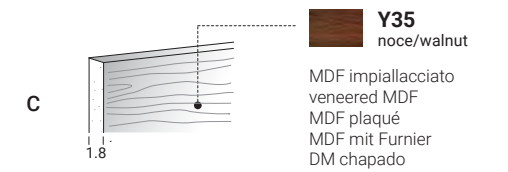
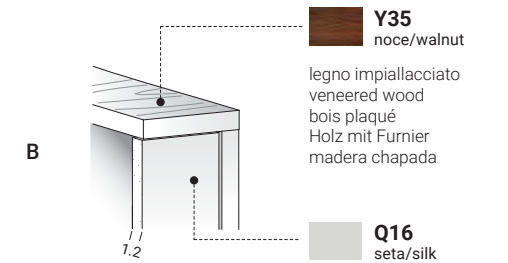
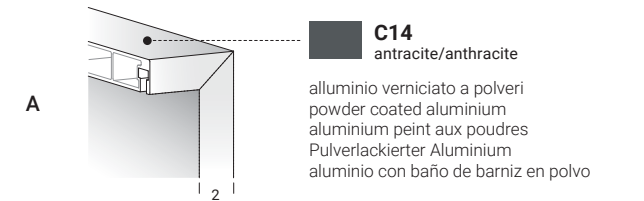
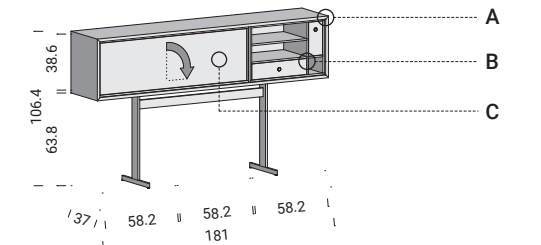

collection info
pg. 26

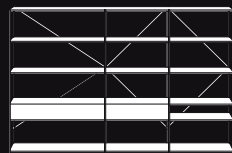

XY

Il brevetto XY consente di posizionare i ripiani lungo l'asse verticale Y e le coppie di profili portanti lungo l'asse orizzontale X. Il posizionamento in X ed Y avviene in continuo, senza posizioni predefinite. Ciò costituisce un'ossatura portante in grado di essere allestita con schienali, fianchi, ante a ribalta, ante a battente, cassettiere.

The patented XY system enables you to position the shelves along vertical Y-axis and the pairs of load-bearing profiles along horizontal X-axis. Positioning along X and Y is completely free, without any preset positions. This creates a load-bearing framework that can be completed with backs, sides, tilting or leaf doors, drawer units.

Le brevet XY permet de positionner les étagères le long de l'axe vertical Y et les paires de profilés portants le long de l'axe horizontal X. Le positionnement suivant X et Y s'effectue en continu, sans positions prédéfinies. Ceci réalise une structure portante susceptible d'être équipée de fonds, côtés, portes à rabattant, portes à battant, kits de tiroirs.

Das Patent XY ermöglicht es, die Böden längs der vertikalen Y-Achse und die tragenden Profilpaare längs der horizontalen X-Achse zu positionieren. Dabei kann die Positionierung auf X und Y an jeder Stelle ohne voreingestellte Positionen erfolgen. Auf diese Weise wird eine tragende Struktur gebildet, die mit Rück- und Seitenwänden, Klapp- und Flügeltüren, Schubladenelementen.

La patente XY permite colocar los estantes a lo largo del eje vertical Y y las parejas de perfiles portantes a lo largo del eje horizontal X. La colocación en X e Y se produce en continuo, sin posiciones previamente definidas. Esto forma un armazón portante capaz de albergar dorso, laterales, puertas abatibles, puertas de batiente, cajoneras.



I ripiani e le coppie di profili verticali sono ordinabili al cm. I due elementi sono completi di tappi terminali, piedini regolabili e fissaggi a parete.

The shelves and the pairs of upright profiles can be ordered in any length, in cm. The two elements are supplied complete with end plugs, adjustable feet and wall attachments.

Les étagères et les paires de profilés verticaux sont réalisables sur mesure au cm. Les deux éléments sont équipés d'obturateurs d'extrémité, de pieds réglables et de fixations murales.

Die Böden und die vertikalen Profilpaare können zentimetergenau am laufenden Meter bestellt werden. Die beiden Elemente werden komplett mit Kapfen für die Enden, verstellbaren Fußena und Wandbefestigungselementen geliefert.

Los estantes y las parejas de perfiles verticales pueden pedirse al centímetro. Los dos elementos están dotados de tapones terminales, pies regulables y sujeciones para su fijación a la pared.

XY materials



alluminio
aluminium
aluminio

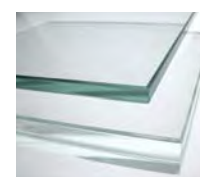

vetro
glass
verre
Glas
cristal



MDF
DM

Le materie prime che costituiscono il sistema XY derivano da un processo di riutilizzo e sono a loro volta riciclabili.

The primary materials used in the system XY are sourced from a reuse process, and are in turn recyclable.

Les matières premières qui composent le système XY dérivent d'un processus de réutilisation et sont à leur tour recyclables.

Die Rohstoffe für das System XY entstammen einem Wiederverwertungsprozess und sind Ihrerseits wiederum recyclebar.

Las materias primas que constituyen el sistema XY proceden de un proceso de reutilización y son, a su vez, reciclables.

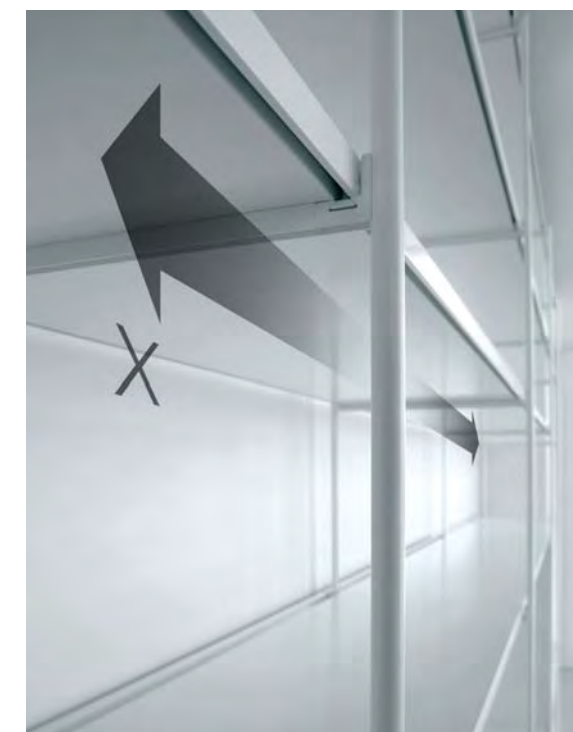

finiture / finishes

telaio / structure / châssis / Gestell / bastidor

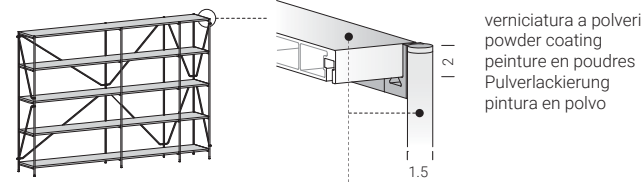

verniciatura a polveri
powder coating
peinture en poudres
Pulverlackierung
pintura en polvo

- C12** bianco white
- C14** antracite anthracite
- C08** nero black

alluminio
aluminium
aluminium
Aluminium
aluminio

100 cm => 50 kg

ante ribalta e cassettiere / tilting doors and drawer units / portes à rabattant et kits de tiroirs
Klapptür und Schubladenelemente / puertas abatibles y cajoneras

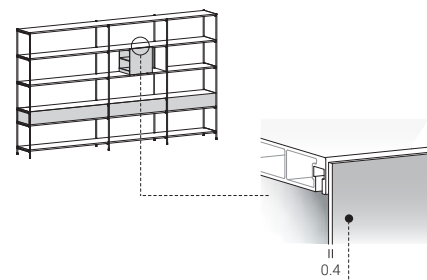

laccato
lacquered
laqué
lackiert
lacado

- Q05** bianco white
- Q16** seta silk
- Q17** corda ecru
- Q20** ghisa cast-iron
- Q14** antracite anthracite
- Q04** nero black
- Q21** bronzo bronze

vetro temprato
tempered glass
verre trempé
Temperglas
cristal templado

dimensioni / dimensions

telaio / structure / châssis / Gestell / bastidor

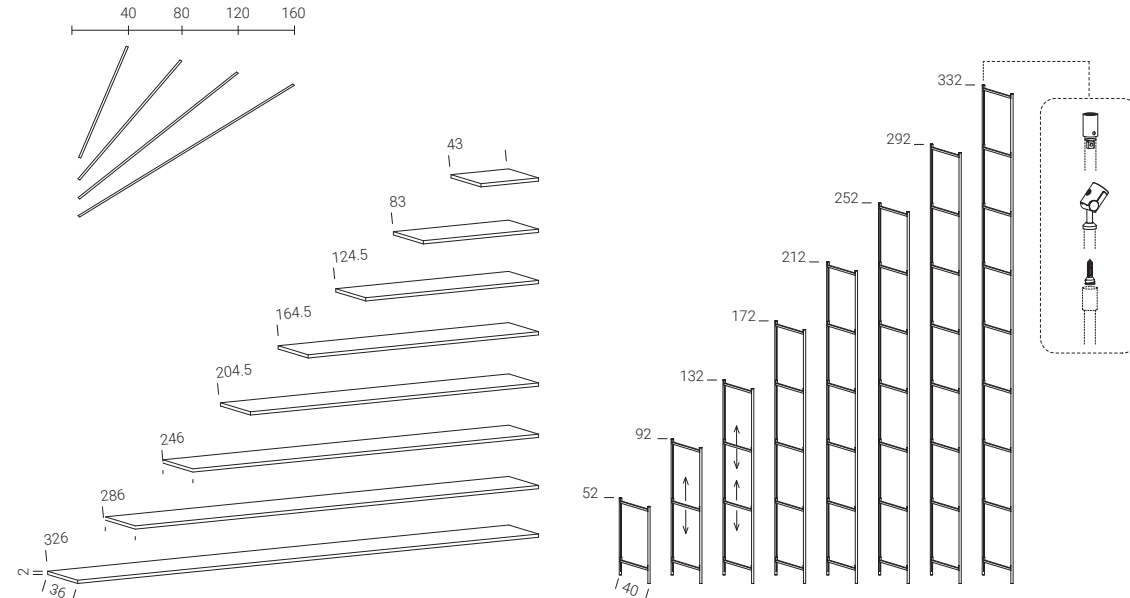

ante ribalta e cassettiere / tilting doors and drawer units / portes à rabattant et kits de tiroirs
Klapptür und Schubladenelemente / puertas abatibles y cajoneras

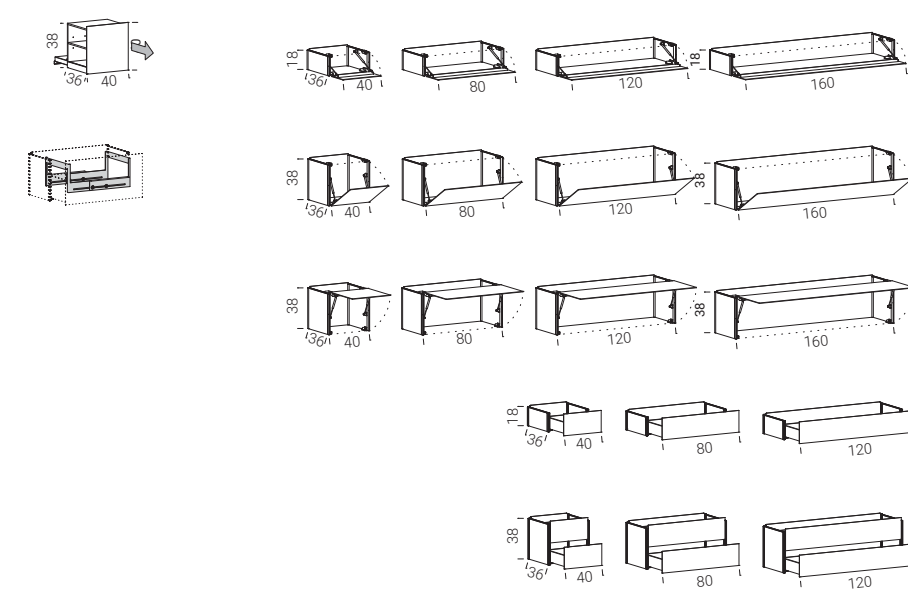

disponibili riduzioni a misura / tailor-made reduction available / disponibles réductions sur mesure
Verkleinerung nach Kundenwunsch / disponibles reducciones a medida

finiture / finishes

ante battente / leaf doors / portes à battant / Flügeltüren / puertas de batiente

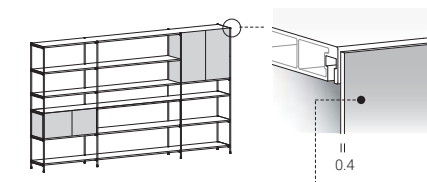

vetro temprato
tempered glass
verre trempé
Temperglas
cristal templado

laccato
lacquered
laqué
lackiert
lacado

- Q05** bianco white
- Q16** seta silk
- Q17** corda ecru
- Q20** ghisa cast-iron
- Q14** antracite anthracite
- Q04** nero black
- Q21** bronzo bronze

schiene, fianchi e top scrivania / backs, sides and desk top / fonds, côtés et plateau bureau
Rückwände, Seitenwände und Schreibtischdeckplatte / dorsos, laterales y superficie de trabajo de escritorio

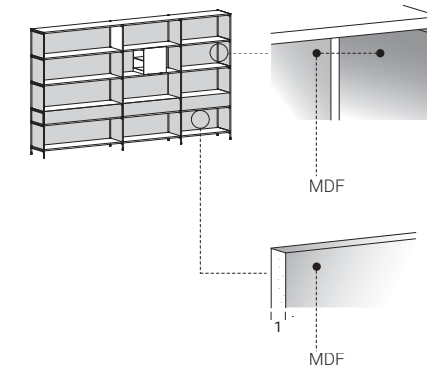

MDF

MDF

laccato
lacquered
laqué
lackiert
lacado

- Q05** bianco white
- Q16** seta silk
- Q17** corda ecru
- Q20** ghisa cast-iron
- Q14** antracite anthracite
- Q04** nero black
- Q21** bronzo bronze

essenze
woods
bois
Holzes
maderas

- Y36** rovere oak
- Y35** noce walnut

multistrato
multilayer
multicouche
Mehrschicht
multiestrato

dimensioni / dimensions

ante battente / leaf doors / portes à battant / Flügeltüren / puertas de batiente

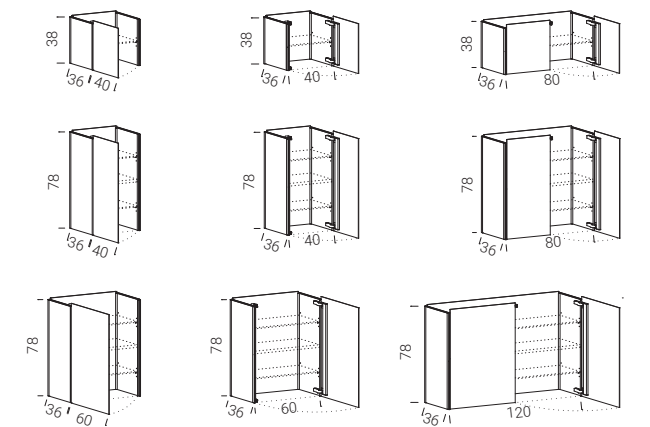

schiene, fianchi e top scrivania / backs, sides and desk top / fonds, côtés et plateau bureau
Rückwände, Seitenwände und Schreibtischdeckplatte / dorsos, laterales y superficie de trabajo de escritorio

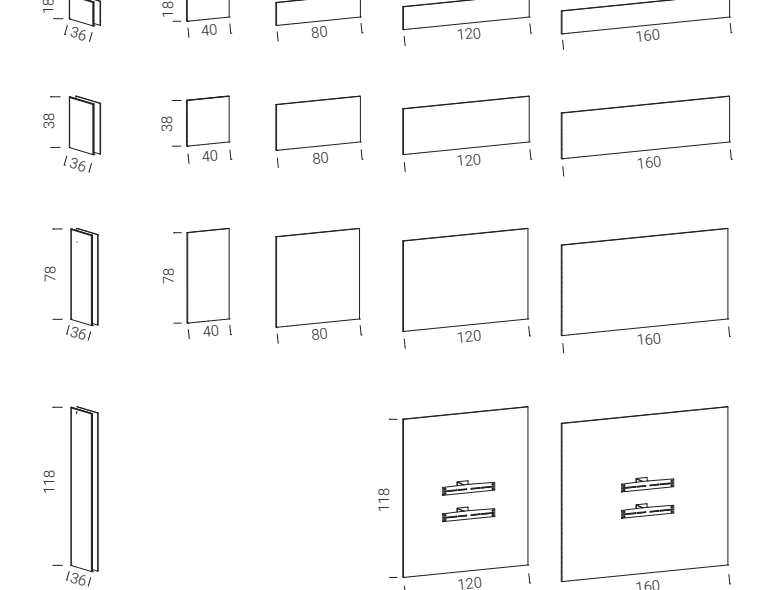



XY
XY30

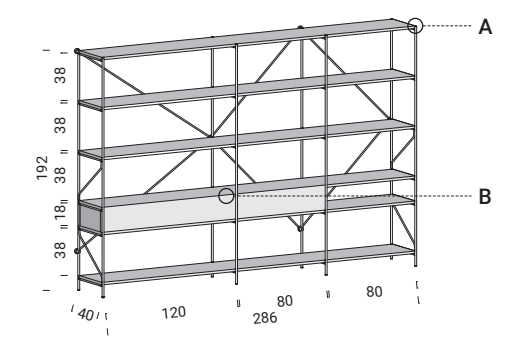

- A**
- C08**
nero/black
- alluminio verniciato a polveri
powder coated aluminium
aluminium peint aux poudres
Pulverlackierter Aluminium
aluminio con baño de barniz en polvo
- B**
- Q04**
nero/black
- vetro temprato laccato
lacquered tempered glass
verre trempé laqué
lackiertem Temperglas
cristal templado lacado

collection info
pg. 50





XY
XY31

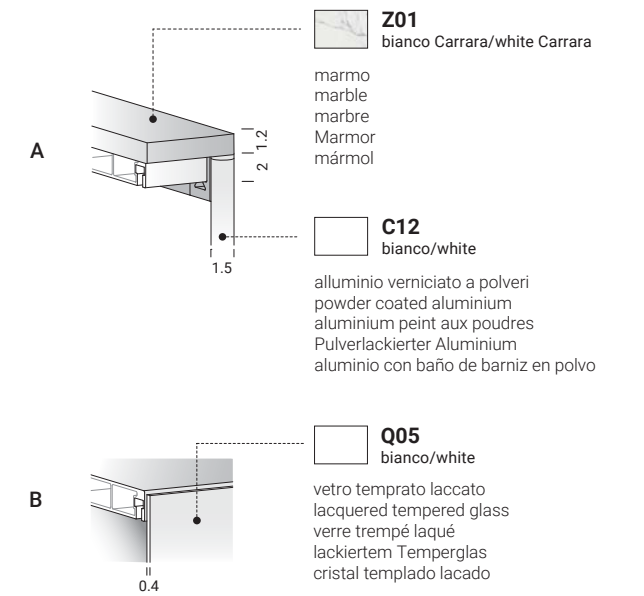
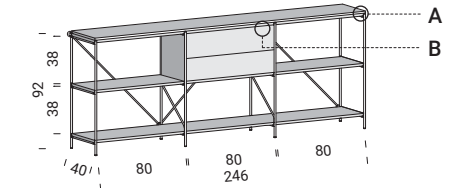

collection info
pg. 50



XY
XY29

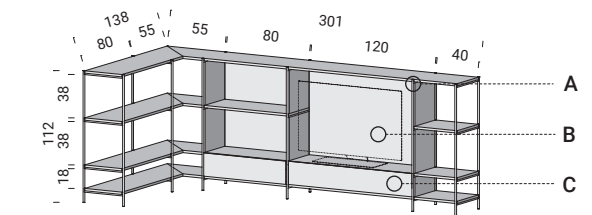

A **C08**
nero/black
alluminio verniciato a polveri
powder coated aluminium
aluminium peint aux poudres
Pulverlackierter Aluminium
aluminio con baño de barniz en polvo

B **Y35**
noce/walnut
MDF impiallacciato
veneered MDF
MDF plaqué
MDF mit Furnier
DM chapado

C **Q04**
nero/black
vetro temprato laccato
lacquered tempered glass
verre trempé laqué
lackiertem Temperglas
cristal templado lacado

collection info
pg. 50





XY
XY28

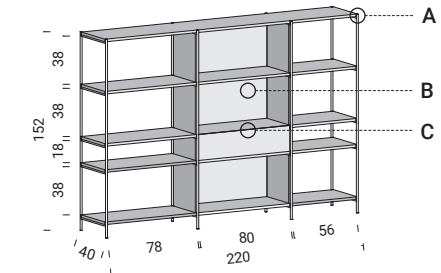

- A**
- C14**
antracite/anthracite
- alluminio verniciato a polveri
powder coated aluminium
aluminium peint aux poudres
Pulverlackierter Aluminium
aluminio con baño de barniz en polvo
- B**
- Y36**
rovere/oak
- MDF impiallacciato
veneered MDF
MDF plaqué
MDF mit Furnier
DM chapado
- C**
- Q14**
antracite/anthracite
- vetro temprato laccato
lacquered tempered glass
verre trempé laqué
lackiertem Temperglas
cristal templado lacado

collection info
pg. 50



XY
XY02

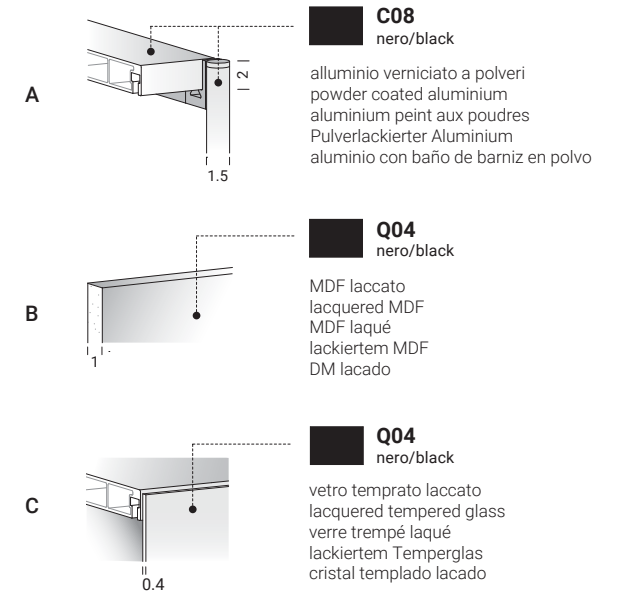
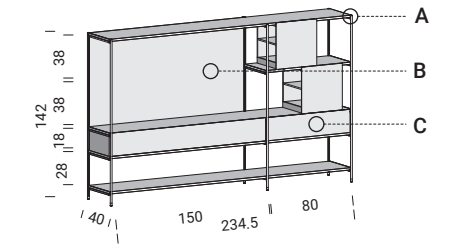

collection info
pg. 50



XY
XY10

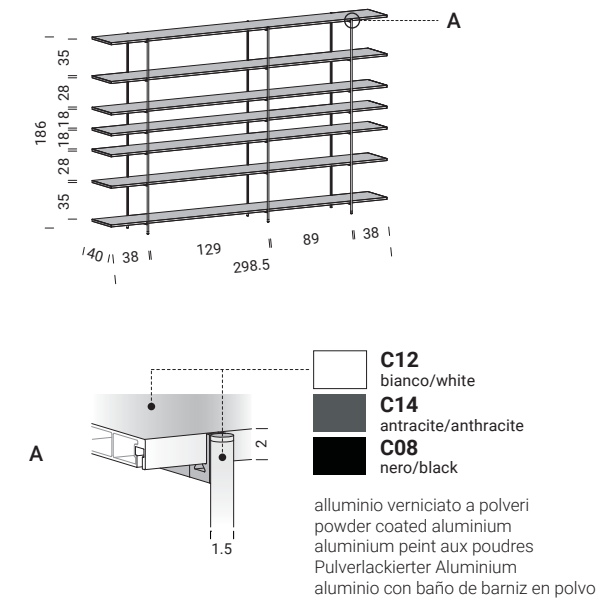

collection info
pg. 50



XY
XY08

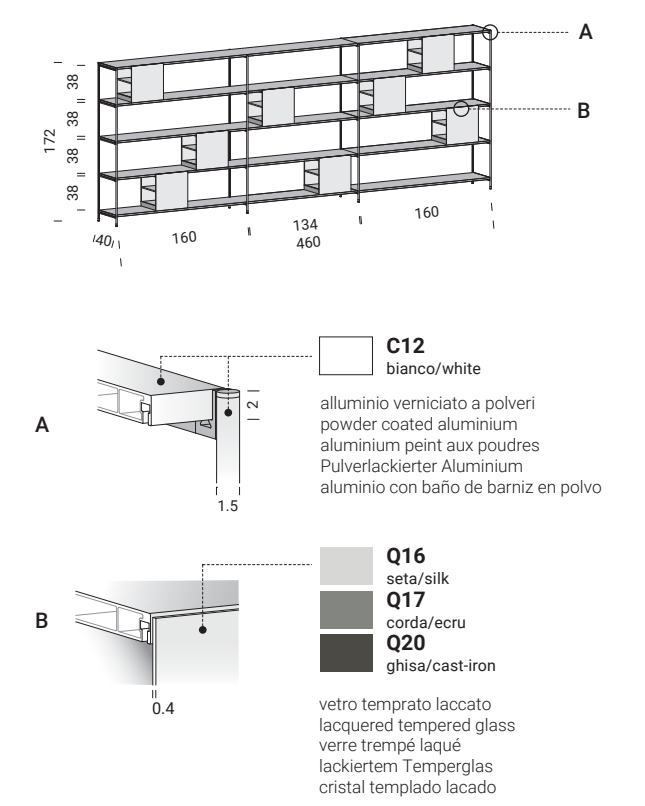

collection info
pg. 50



XY
XY09

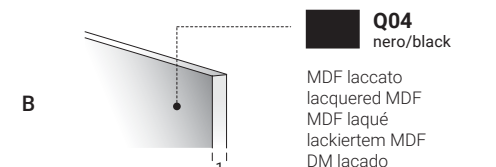
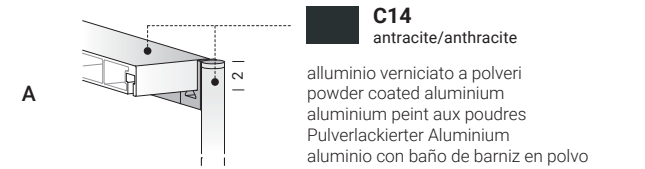
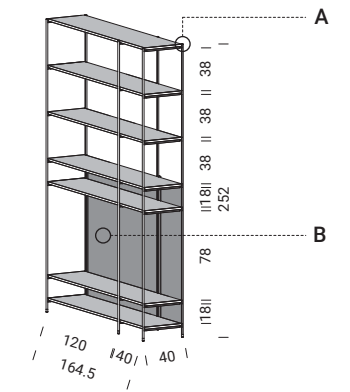

collection info
pg. 50



XY
XY03

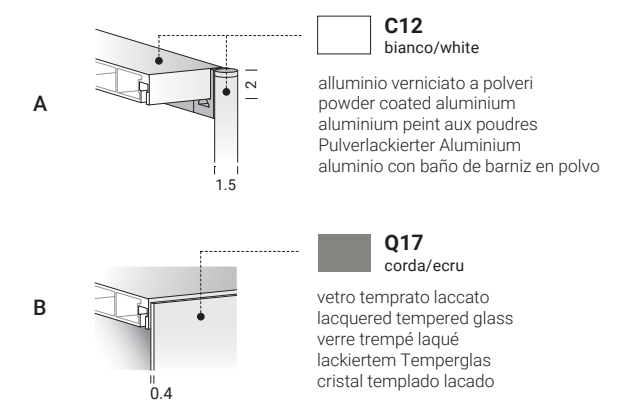
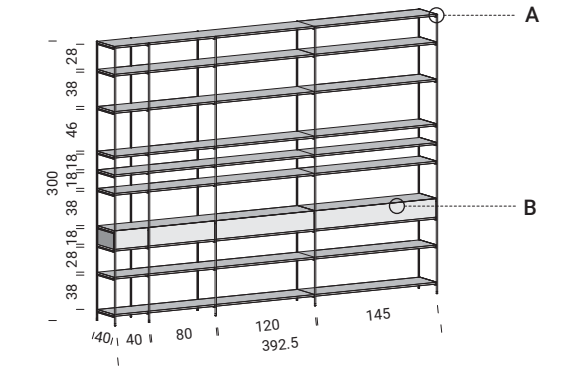

collection info
pg. 50



XY
XY15

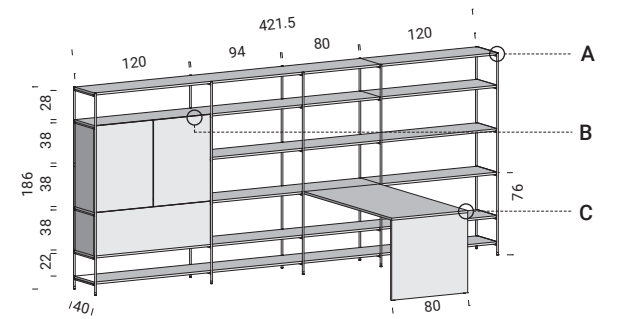

- A** **C12**
bianco/white
alluminio verniciato a polveri
powder coated aluminium
aluminium peint aux poudres
Pulverlackierter Aluminium
aluminio con baño de barniz en polvo
- B** **Q05**
bianco/white
vetro temprato laccato
lacquered tempered glass
verre trempé laqué
lackiertem Temperglas
cristal templado lacado
- C** **Q05**
bianco/white
multistrato laccato
lacquered multilayer
laccato multistrato
lackiertem Mehrschicht
multiestrato lacado

collection info
pg. 50

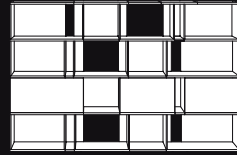

from>to

Ogni composizione di from>to è configurabile utilizzando 6 moduli base, determinati da tre variabili in larghezza (40-60-80 cm) e due in altezza (40-20 cm). Scegliendo un numero di moduli a piacere, essi possono essere affiancati ad intervallo variabile al millimetro e sovrapposti secondo semplici regole compositive.

Each composition of from>to is configured using 6 basic modules, determined by three width variables (40-60-80 cm) and two height variables (40-20 cm). The number of modules can be freely chosen, and they can then be assembled horizontally at variable intervals to the millimetre and vertically following simple rules.

Chaque composition de from>to est configurable en utilisant 6 modules de base, déterminés par trois variables en largeur (40-60-80 cm) et deux en hauteur (40-20 cm). En sélectionnant un nombre de modules au choix, ceux-ci peuvent être placés côte à côte à intervalle variable au millimètre et superposés suivant de simples règles de composition.

Jede Komposition von from>to kann mit 6 Basismodulen konfiguriert werden, die in drei Breiten (40-60-80 cm) und zwei Höhen (40-20 cm) angeboten werden. Nachdem ganz nach Belieben eine Anzahl von Modulen gewählt wurde, können diese mit millimetergenauem Abstand nebeneinander und nach einfachen Regeln übereinander gesetzt werden.

Cada composición de from>to se puede configurar utilizando 6 módulos base, con tres variables de anchura (40-60-80 cm) y dos de altura (40-20 cm). Se puede elegir el número de módulos que se desee, pudiéndose colocar uno al lado de otro según un intervalo de milímetros variable y superponerse según unas reglas simples de composición.

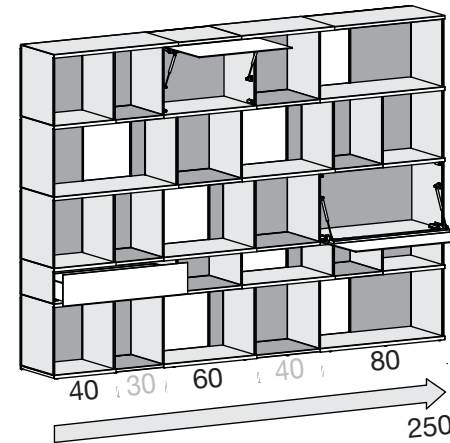
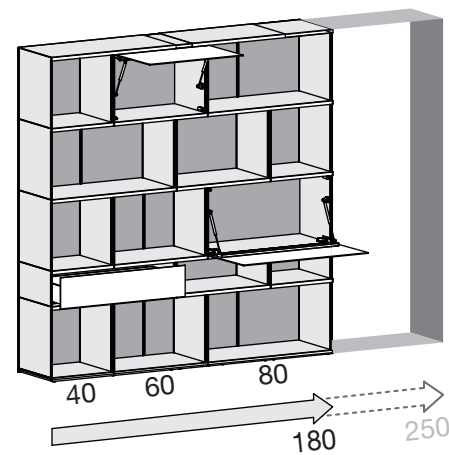
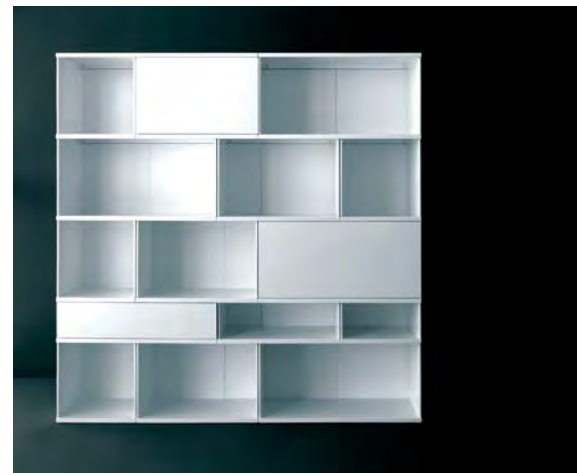

from>to materials

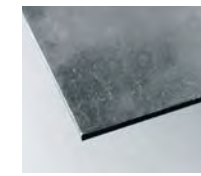

acciaio
steel
acier
Stahl
acero

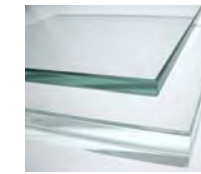

vetro
glass
verre
Glas
cristal



MDF
DM

Le materie prime che costituiscono il sistema from>to derivano da un processo di riutilizzo e sono a loro volta riciclabili.

The primary materials used in the system from>to are sourced from a reuse process, and are in turn recyclable.

Les matières premières qui composent le système from>to dérivent d'un processus de réutilisation et sont à leur tour recyclables.

Die Rohstoffe für das System from>to entstammen einem Wiederverwertungsprozess und sind Ihrerseits wiederum recyclebar.

Las materias primas que constituyen el sistema from>to proceden de un proceso de reutilización y son, a su vez, reciclables.

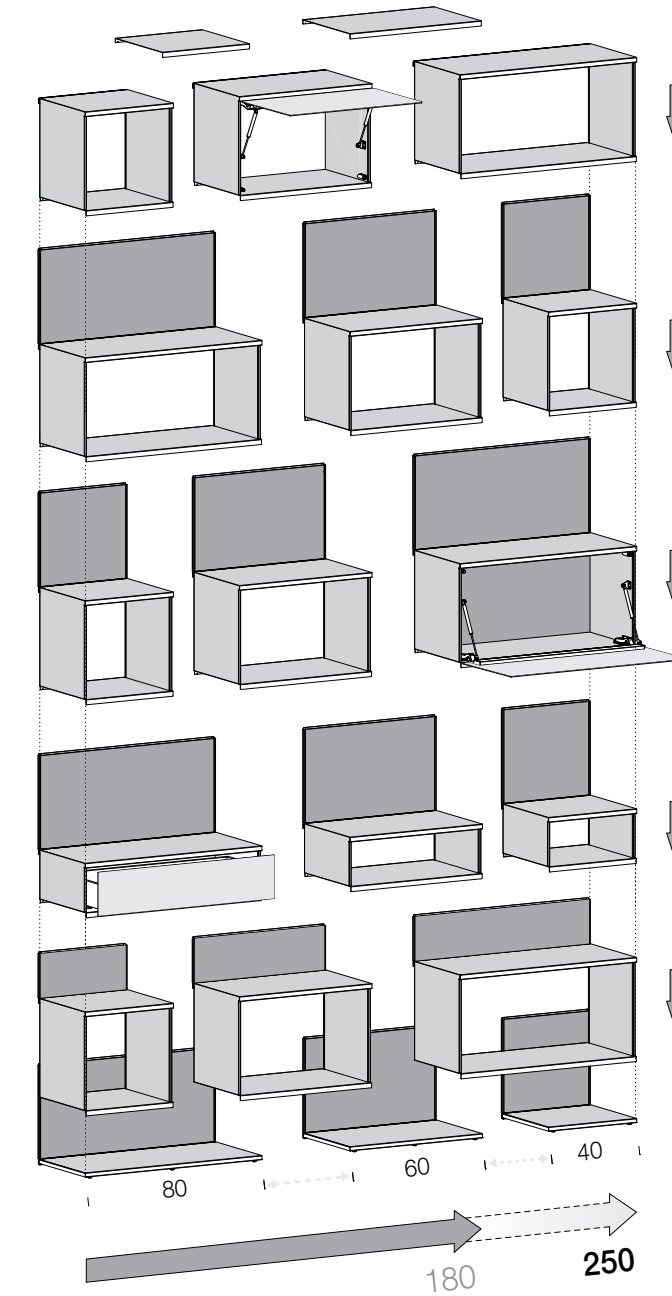

finiture / finishes

scocche / shells / cadres / Gehäuse / estructuras

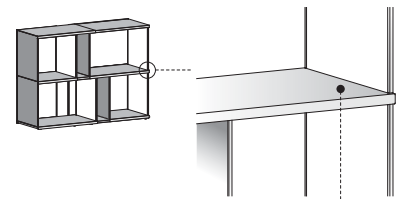

acciaio
steel
acier
Stahl
acero

verniciatura a polveri
powder coating
peinture en poudres
Pulverlackierung
pintura en polvo

	C12 bianco white
	C21 seta silk
	C08 nero black
	C23 corda ecru
	C30 ghisa cast-iron
	C14 antracite anthracite
	C29 bronzo bronze

fianchi e schiene / internal sides and backs / fonds intérieurs et côtés / Seiten- und Rückenwände / laterales y traseras

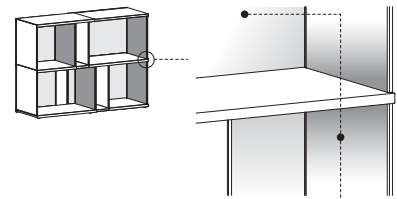

MDF

laccato
lacquered
laqué
lackiert
lacado

	Q05 bianco white
	Q16 seta silk
	Q17 corda ecru
	Q20 ghisa cast-iron
	Q14 antracite anthracite
	Q04 nero black
	Q21 bronzo bronze

essenze
woods
bois
Holzes
maderas

	Y36 rovere oak
	Y35 noce walnut

frontali / doors fronts / faces des portes / Fronten der Türen / frontales de las puertas

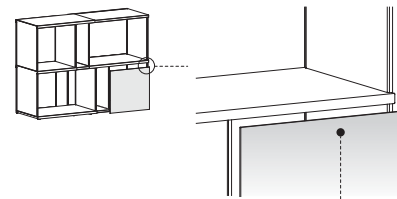

vetro temprato
tempered glass
verre trempé
Temperglas
cristal templado

laccato
lacquered
laqué
lackiert
lacado

	Q05 bianco white
	Q16 seta silk
	Q17 corda ecru
	Q20 ghisa cast-iron
	Q14 antracite anthracite
	Q04 nero black
	Q21 bronzo bronze

configurazioni / configurations

moduli / modules / modules / Modulen / módulos

60 + 40

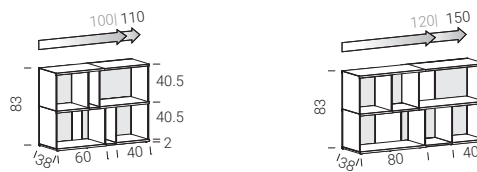

80 + 40

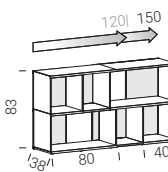

60 + 40 + 40

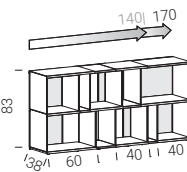

80 + 60 + 40

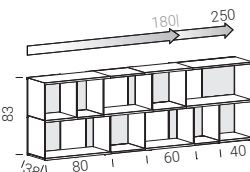

80 + 80 + 40

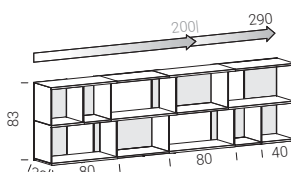

80 + 80 + 60 + 40

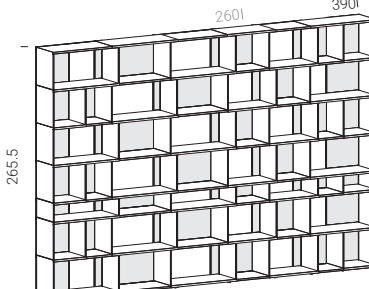
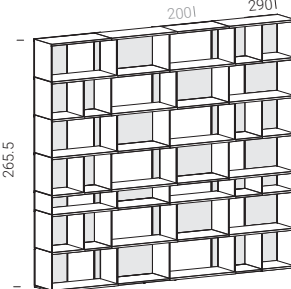
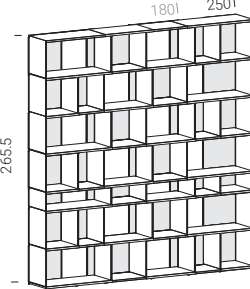
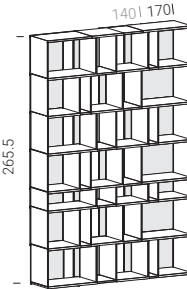
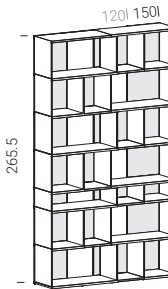
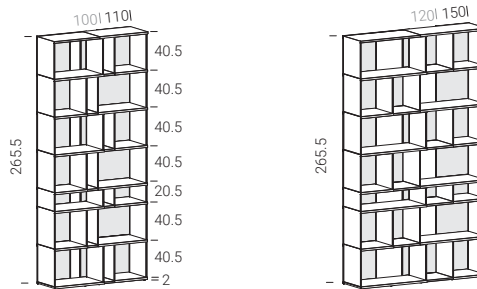
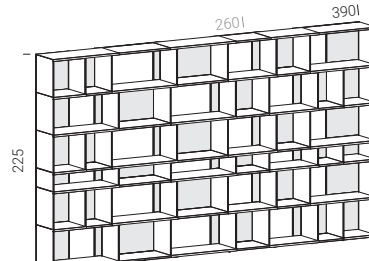
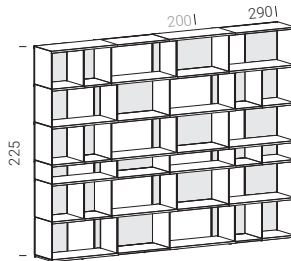
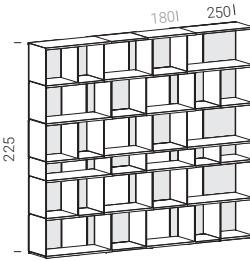
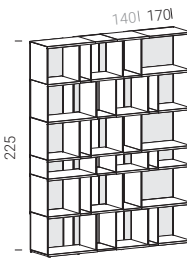
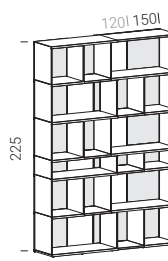
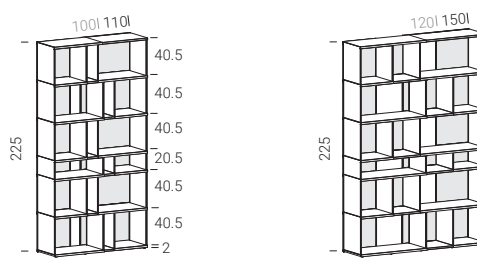
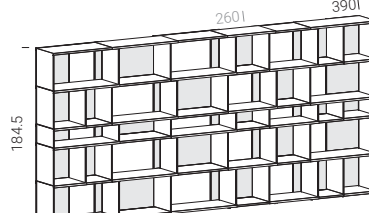
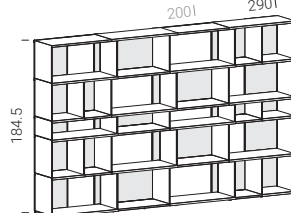
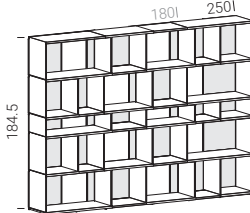
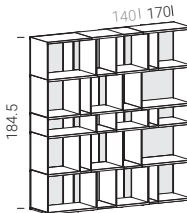
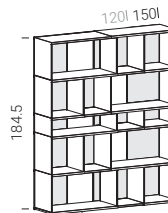
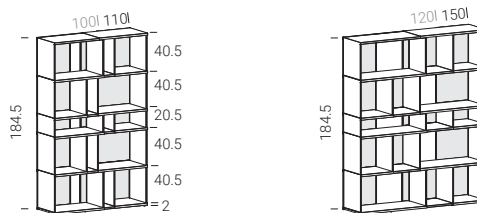
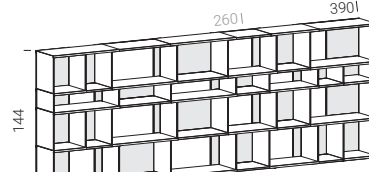
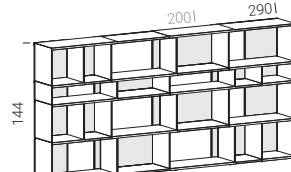
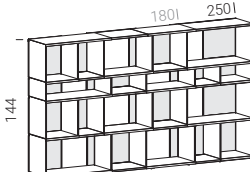
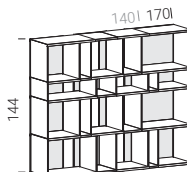
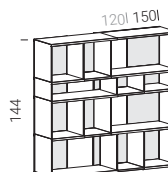
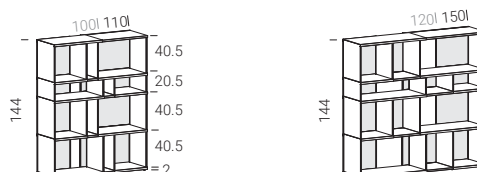
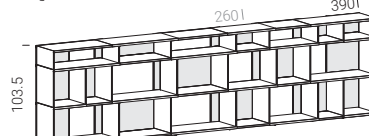
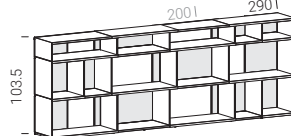
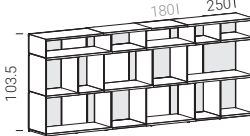
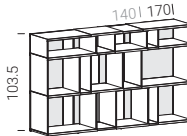
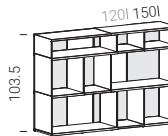
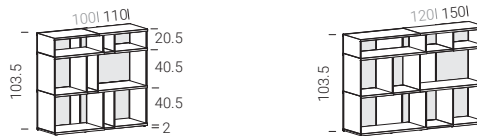
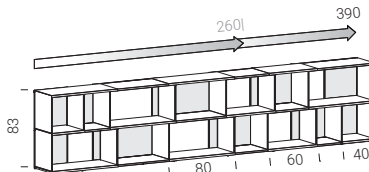

elementi di chiusura / closure elements / éléments de fermeture Schließelemente / elementos de cierre

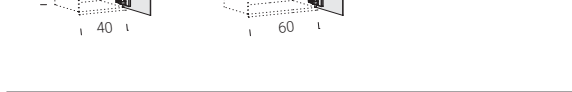
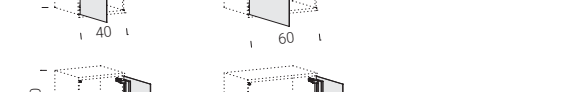
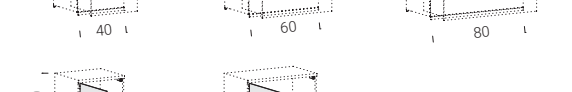
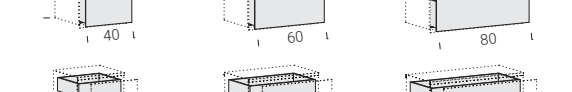
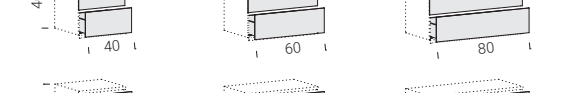
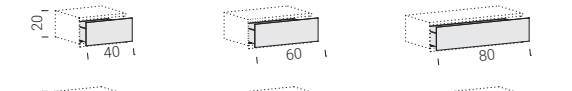
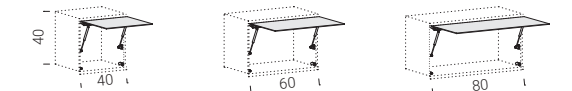
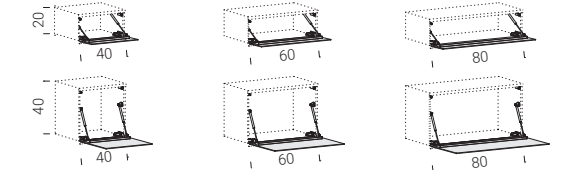

accessori / accessories / accessoires / Zubehör / accesorios

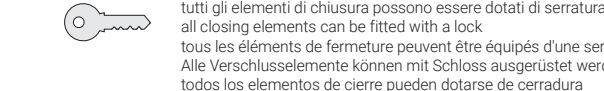
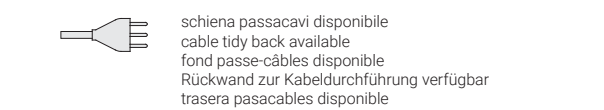
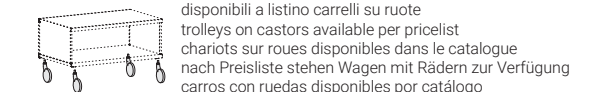

disponibili a listino ulteriori composizioni / further compositions available per pricelist / autres compositions disponibles sur la liste de prix / nach Preisliste stehen weitere Zusammenstellungen zur Verfügung / otras composiciones disponibles en la lista de precios

tutti gli elementi di chiusura possono essere dotati di serratura
all closing elements can be fitted with a lock
tous les éléments de fermeture peuvent être équipés d'une serrure
Alle Verschlüsselemente können mit Schloss ausgerüstet werden
todos los elementos de cierre pueden dotarse de cerradura

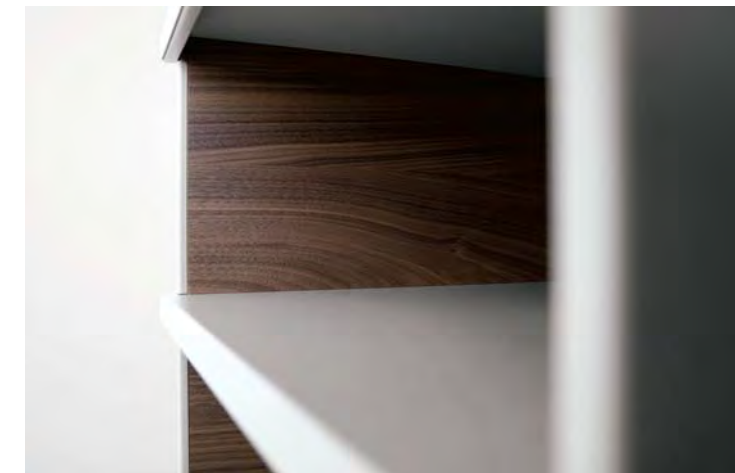

from>to
FT30

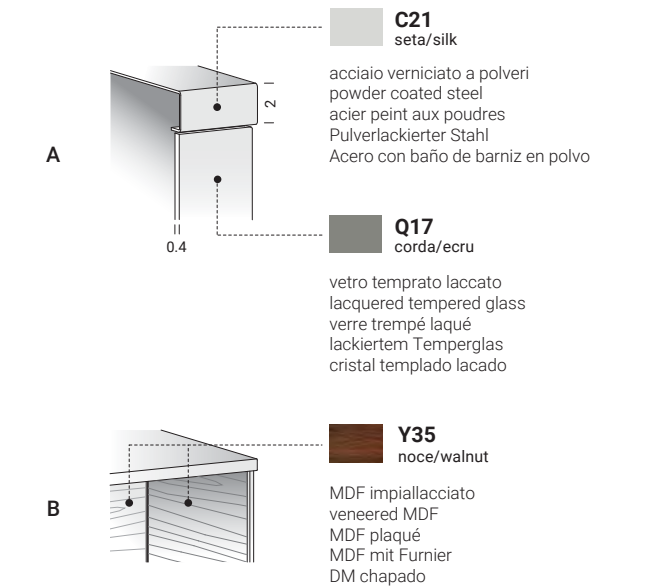
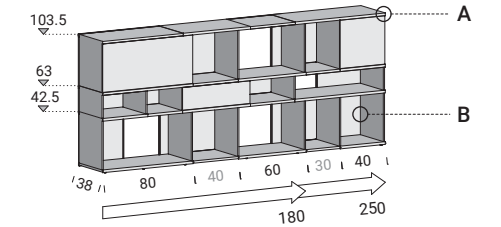

collection info
pg. 76



from>to
FT02

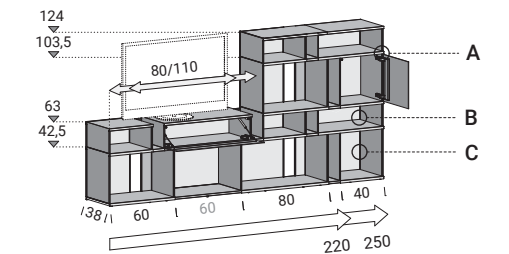

A

C08
nero/black
acciaio verniciato a polveri
powder coated steel
acier peint aux poudres
Pulverlackierter Stahl
Acero con baño de barniz en polvo

Q17
corda/ecru
vetro temprato laccato
lacquered tempered glass
verre trempé laqué
lackiertem Temperglas
cristal templado lacado

B

Y36
rovere/oak
MDF impiallacciato
veneered MDF
MDF plaqué
MDF mit Furnier
DM chapado

C

Q17
corda/ecru
MDF laccato
lacquered MDF
MDF laqué
lackiertem MDF
DM lacado

collection info
pg. 76



from>to
FT03

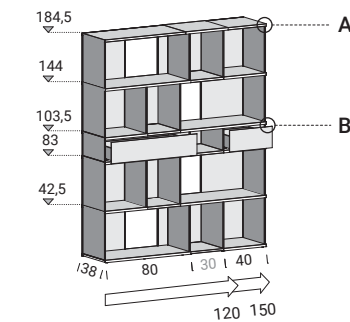

C12
bianco/white
acciaio verniciato a polveri
powder coated steel
acier peint aux poudres
Pulverlackierter Stahl
Acero con baño de barniz en polvo

Q05
bianco/white
vetro temprato laccato
lacquered tempered glass
verre trempé laqué
lackiertem Temperglas
cristal templado lacado

Y36
rovere/oak
MDF impiallacciato
veneered MDF
MDF plaqué
MDF mit Furnier
DM chapado

collection info
pg. 76



from>to
FT01

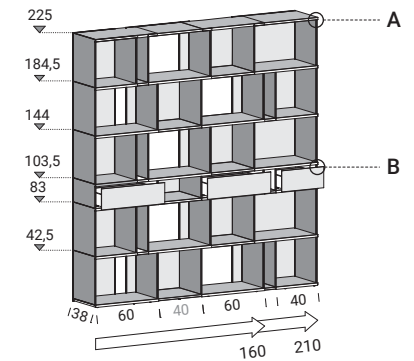

- A**
- Q17**
corda/ecru
 - MDF laccato
lacquered MDF
MDF laqué
lackiertem MDF
DM lacado
- B**
- C21**
seta/silk
 - acciaio verniciato a polveri
powder coated steel
acier peint aux poudres
Pulverlackierter Stahl
Acero con baño de barniz en polvo
 - Q17**
corda/ecru
 - vetro temprato laccato
lacquered tempered glass
verre trempé laqué
lackiertem Temperglas
cristal templado lacado

collection info
pg. 76



from>to
FT05A

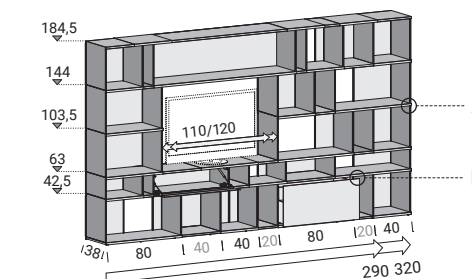

- Y36**
rovere/oak
MDF impiallacciato
veneered MDF
MDF plaqué
MDF mit Furnier
DM chapado
- Q17**
corda/ecru
MDF laccato
lacquered MDF
MDF laqué
lackiertem MDF
DM lacado
- C12**
bianco/white
acciaio verniciato a polveri
powder coated steel
acier peint aux poudres
Pulverlackierter Stahl
Acero con baño de barniz en polvo
- Q05**
bianco/white
vetro temprato laccato
lacquered tempered glass
verre trempé laqué
lackiertem Temperglas
cristal templado lacado

collection info
pg. 76



from>to
FT04

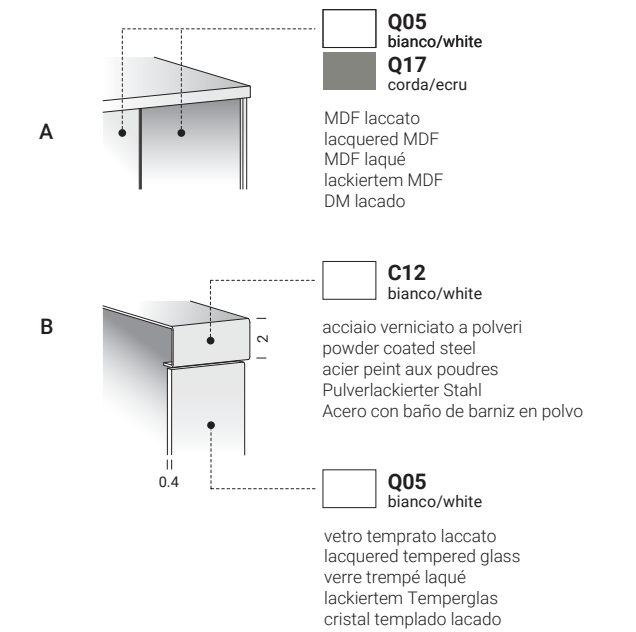
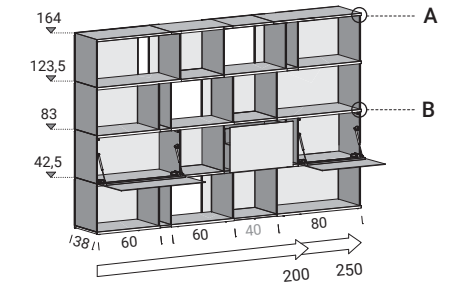

collection info
pg. 76



system

Il sistema brevettato extendo è formato da due profili in alluminio estensibili, adattabili alle diverse altezze degli ambienti. Agendo sulla leva a scomparsa, i profili si bloccano all'altezza desiderata e si comprimono tra pavimento e soffitto, senza l'utilizzo di alcun utensile o pre-fissaggio.

The patented extendo system consists of two extendable aluminium profiles that can be adapted to environments of various heights. Using the foldaway lever, the profiles can be blocked at the desired height and compressed between floor and ceiling, without having to use any kind of pre-fixing tool.

Le système breveté extendo est constitué de deux profilés extensibles en aluminium pouvant être adaptés aux différentes hauteurs des milieux. En agissant sur le levier escamotable, les profilés se verrouillent à la hauteur souhaitée et se compriment entre plancher et plafond, sans utiliser aucun outil ou préfixation.

El sistema patentado extendo está formado por dos perfiles de aluminio extensibles, adaptables a las distintas alturas de los ambientes. Actuando sobre la palanca escondida, los perfiles se bloquean a la altura deseada y se comprimen entre el suelo y el techo, sin que sea necesario utilizar ninguna herramienta o fijación previa.

Das patentierte System extendo besteht aus zwei ausziehbaren Aluminium-Profilen, die an unterschiedliche Raumhöhen angepasst werden können. Durch einen versenkbaren Hebel werden die Profile auf der gewünschten Höhe blockiert und zwischen Fußboden und Zimmerdecke ohne Werkzeug oder Vor-Befestigung komprimiert eingesetzt.



Lasta telescopica extendo esercita una spinta dinamica verso l'alto che consente di assorbire eventuali variazioni d'altezza tra pavimento e soffitto che possono avvenire nel corso del tempo. Per progettare senza vincoli ogni spazio, sono disponibili adattatori soffitto cartongesso, soffitto inclinato e a parete.

The extendo telescopic rod exerts dynamic upward pressure, so that it can absorb any height variations between the floor and ceiling that may occur over time. In order to design any space without limitations, adaptors are available for plasterboard ceilings, sloped ceilings and walls.

La tige télescopique extendo exerce une poussée dynamique vers le haut qui permet d'absorber les éventuelles variations de hauteur entre le plancher et le plafond susceptibles de se présenter au fil du temps. Pour concevoir tout espace sans contraintes, des adaptateurs pour plafond en placo-plâtre, plafond incliné et pour application murale sont disponibles.

system materials



alluminio
aluminium
Aluminium
aluminio

Le materie prime che costituiscono il sistema system derivano da un processo di riutilizzo e sono a loro volta riciclabili.

The primary materials used in the system "system" are sourced from a reuse process, and are in turn recyclable.

Les matières premières qui composent le système system dérivent d'un processus de réutilisation et sont à leur tour recyclables.

Die Rohstoffe für das System "system" entstammen einem Wiederverwertungsprozess und sind Ihrerseits wiederum recyclebar.

Las materias primas que constituyen el sistema system proceden de un proceso de reutilización y son, a su vez, reciclables.



Die Teleskopstange extendo übt einen dynamischen Druck nach oben aus, wodurch mögliche Änderungen des Abstands zwischen Boden und Decke, wie sie im Lauf der Zeit auftreten können, aufgefangen werden. Um jeden Raum ohne Einschränkungen planen zu können, sind Adapter zur Befestigung an Decken aus Gipskarton, Dachschrägen und an Wänden erhältlich.

La barra telescópica extendo ejerce un empuje dinámico hacia arriba que permite absorber las variaciones de altura entre el suelo y el techo que se pueden dar con el tiempo. Para diseñar sin limitaciones cualquier espacio, existen adaptadores de cartón-yeso para techo, techo inclinado y pared.

Profilo extendo con attacco a parete disponibile in tre altezze o con supporto a pavimento autoportante.

Extendo profile with wall coupling available in three heights or with freestanding floor support.

Profilé extendo avec fixation murale disponible en trois hauteurs ou avec support au sol autoportant.

Das extendo Profil mit Wandbefestigung steht in drei verschiedenen Höhen oder mit selbsttragender Bodenhalterung zur Verfügung.

Perfil extendo con sujeción a pared disponible en tres alturas y con soporte autónomo al suelo.

finiture / finishes

extendo

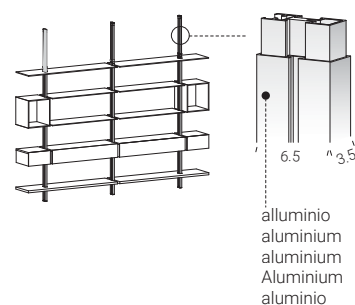

verniciatura a polveri
powder coating
peinture en poudres
Pulverlackierung
pintura en polvo

	C12	bianco white
	C21	seta silk
	C30	ghisa cast-iron
	C08	nero black

ripiani / shelves / étagères / Böden / estantes

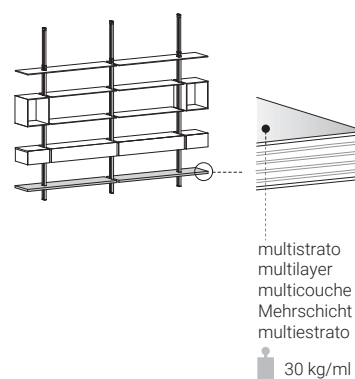

laccato
lacquered
laqué
lackiert
lacado

	Q05	bianco white
	Q16	seta silk
	Q17	corda ecru
	Q20	ghisa cast-iron
	Q14	antracite anthracite
	Q04	nero black
	Q21	bronzo bronze

ripiani / shelves / étagères / Böden / estantes

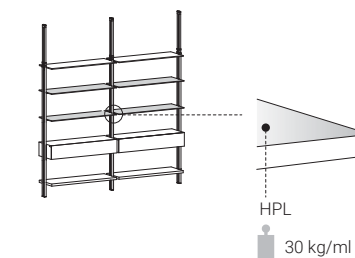

HPL		L03	bianco white
FENIX NTM		L08	grigio Londra London grey
FENIX NTM		L06	nero black
essenze woods bois Holzes maderas		Y37	rovere affumicato smoked oak
		Y38	rovere nero black oak

laccato lacquered laqué lackiert lacado		Q05	bianco white
		Q16	seta silk
		Q17	corda ecru
		Q20	ghisa cast-iron
		Q14	antracite anthracite
		Q04	nero black
		Q21	bronzo bronze

dimensioni / dimensions

extendo

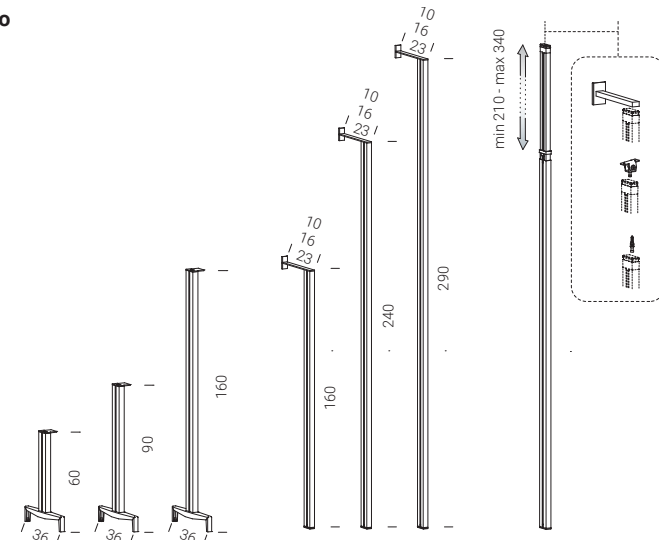

disponibili riduzioni a misura / tailor-made reduction available / disponibles réductions sur mesure
cm Verkleinerung nach Kundenwunsch / disponibles reducciones a medida

ripiani / shelves / étagères / Böden / estantes

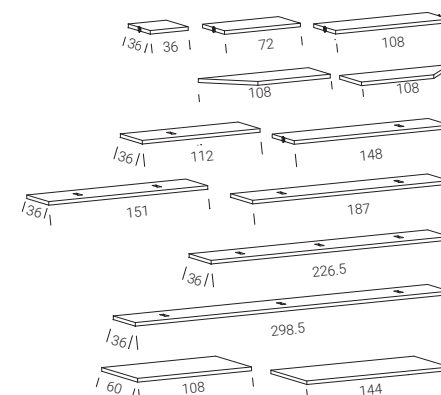

ripiani in HPL / HPL shelves / étagères / Böden / estantes

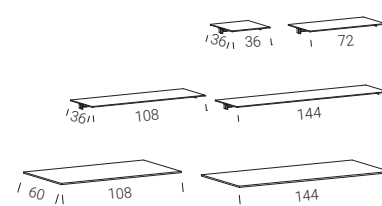

finiture / finishes

ripiani / shelves / étagères / Böden / estantes

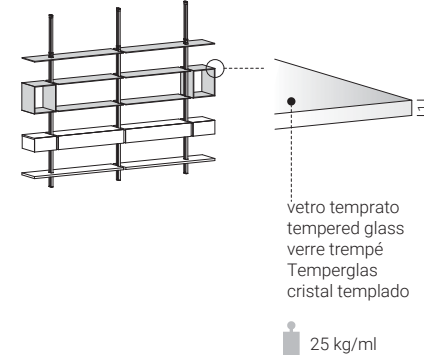

laccato
lacquered
laqué
lackiert
lacado

	V01	bianco white
	V15	seta silk
	V16	corda ecru
	V23	ghisa cast-iron
	V12	antracite anthracite
	V02	nero black
	V24	bronzo bronze
	V06	fumè smoked

contenitori / cabinets / modules de rangement / Behälter / contenedores

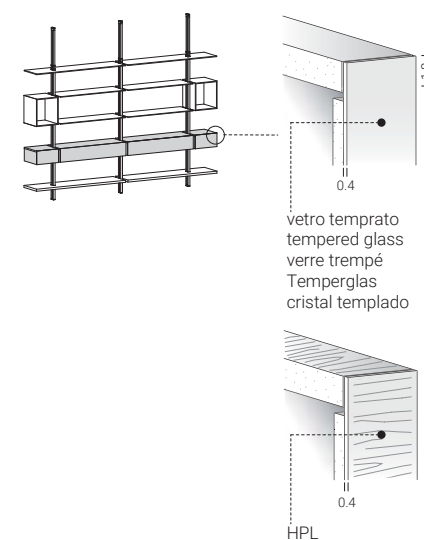

laccato
lacquered
laqué
lackiert
lacado

	Q05	bianco white
	Q16	seta silk
	Q17	corda ecru
	Q20	ghisa cast-iron
	Q14	antracite anthracite
	Q04	nero black
	Q21	bronzo bronze

essenze woods bois Holzes maderas		Y37	rovere affumicato smoked oak
		Y38	rovere nero black oak

accessori / accessories / accessoires / Zubehör / accesorios

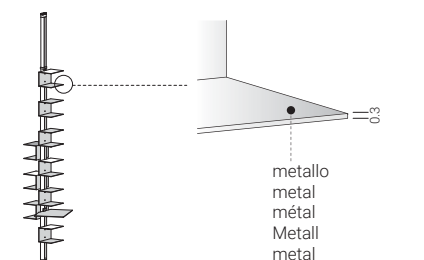

verniciatura a polveri
powder coating
peinture en poudres
Pulverlackierung
pintura en polvo

	C12	bianco white
	C21	seta silk
	C30	ghisa cast-iron
	C08	nero black

dimensioni / dimensions

ripiani / shelves / étagères / Böden / estantes

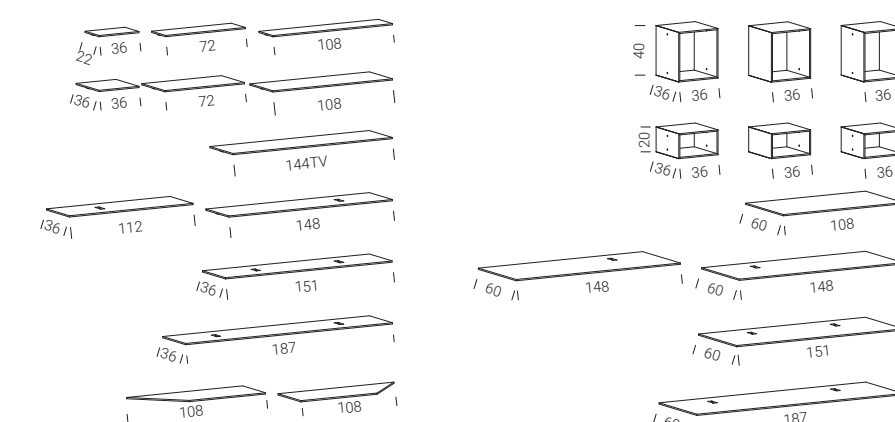

contenitori / cabinets / modules de rangement / Behälter / contenedores

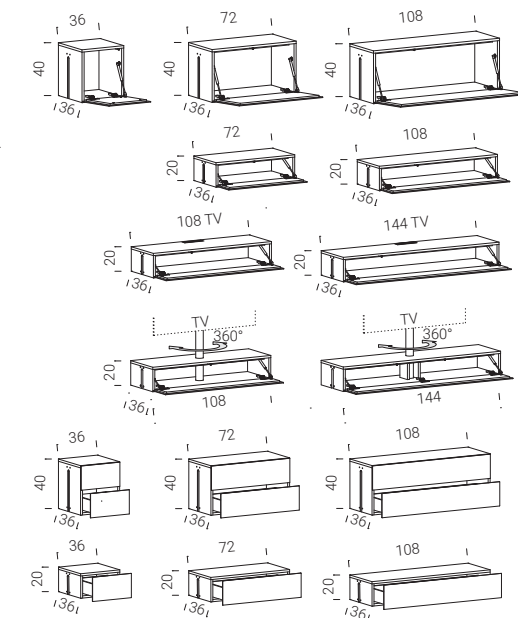

accessori / accessories / accessoires / Zubehör / accesorios

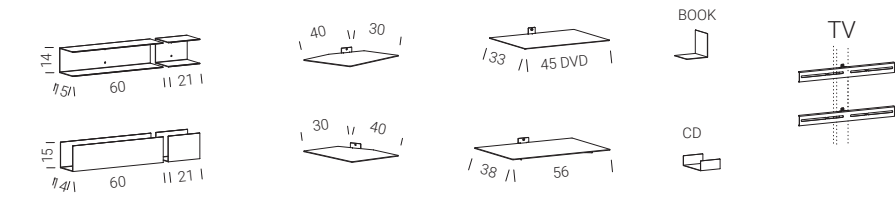



system
SY54

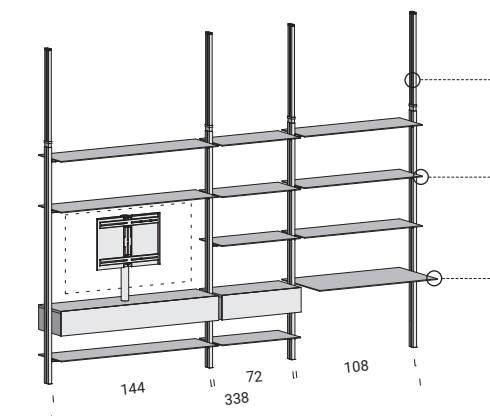

A

C08
nero/black

alluminio verniciato a polveri
powder coated aluminium
aluminium peint aux poudres
Pulverlackierter Aluminium
aluminio con baño de barniz en polvo

6.5 3.5

B

Y37
rovere affumicato/smoked oak

HPL impiallacciato
wood-veneered HPL
HPL plaqué bois
HPL mit Holz furnier
HPL contrachapado madera

0.6

C

L06
nero/black

HPL **FENIX** NTM

0.6

collection info
pg. 92





system
SY13

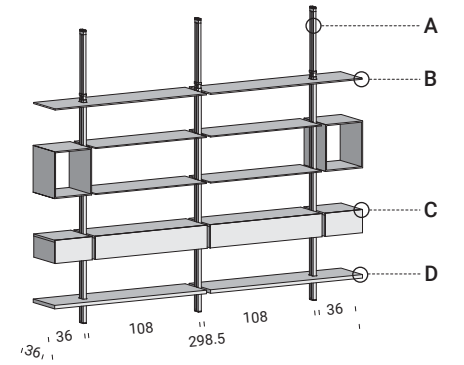

- A**

C12
bianco/white
alluminio verniciato a polveri
powder coated aluminium
aluminium peint aux poudres
Pulverlackierter Aluminium
aluminio con baño de barniz en polvo
- B**

V01
bianco/white
vetro temprato laccato
lacquered tempered glass
verre trempé laqué
lackiertem Temperglas
cristal templado lacado
- C**

Q05
bianco/white
vetro temprato laccato
lacquered tempered glass
verre trempé laqué
lackiertem Temperglas
cristal templado lacado
- D**

Q05
bianco/white
multistrato laccato
lacquered multilayer
multicouche laqué
lackiertem Mehrschicht
multiestrato lacado

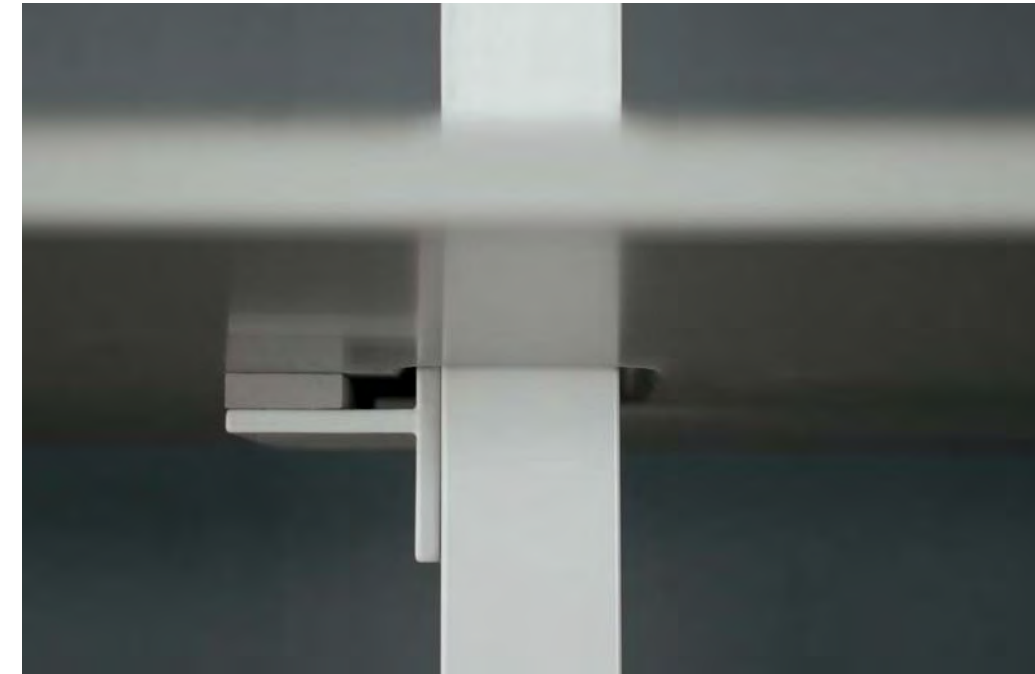

system
SY03

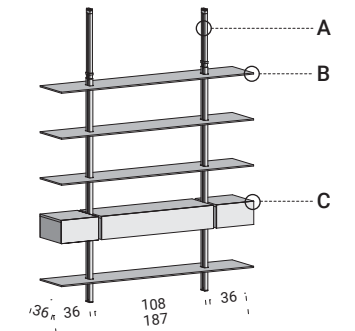

A

C21
seta/silk

alluminio verniciato a polveri
powder coated aluminium
aluminium peint aux poudres
Pulverlackierter Aluminium
aluminio con baño de barniz en polvo

B

V16
corda/ecru

vetro temprato laccato
lacquered tempered glass
verre trempé laqué
lackiertem Temperglas
cristal templado lacado

C

Y38
rovere nero/black oak

HPL impiallacciato
wood-veneered HPL
HPL plaqué bois
HPL mit Holzfurnier
HPL contrachapado madera

collection info
pg. 92



system
SY04

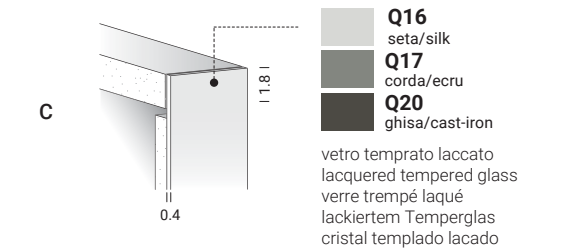
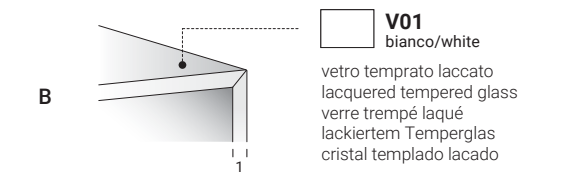
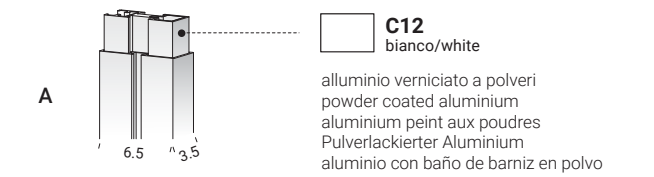
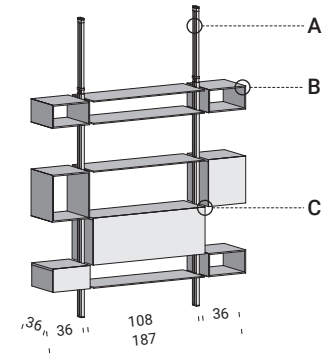

collection info
pg. 92



system SY16

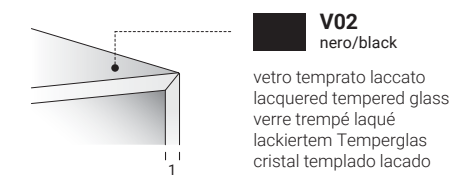
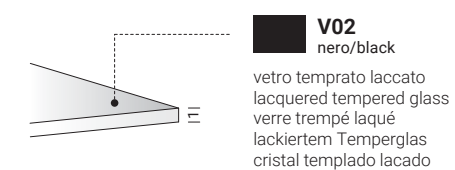
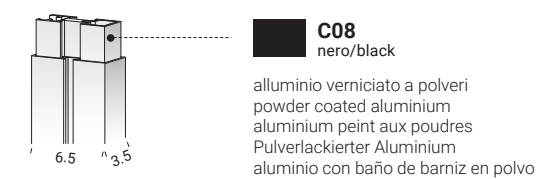
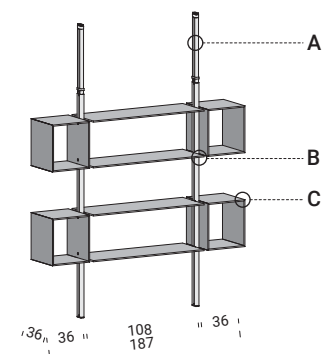

collection info
pg. 92

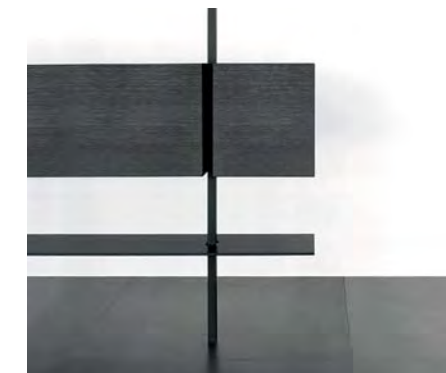
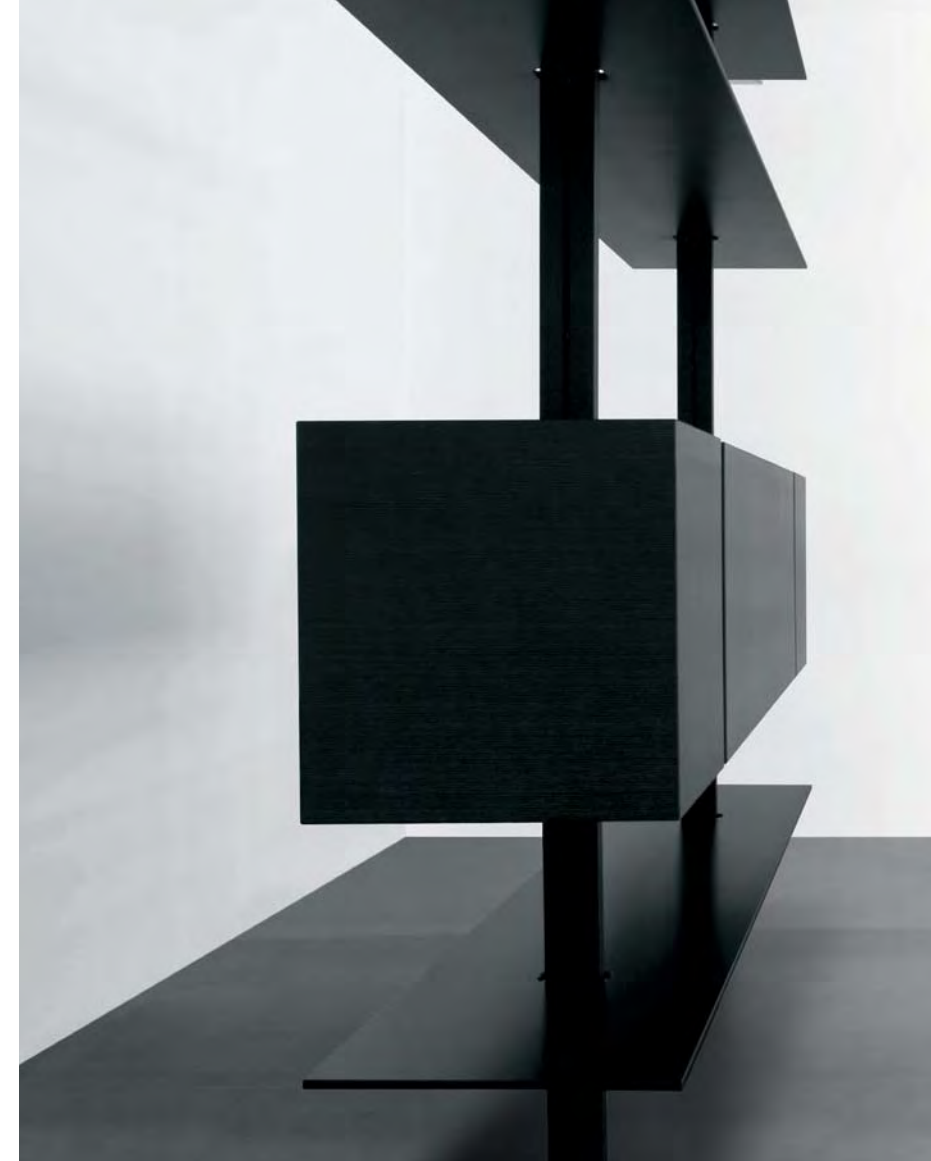

system SY14

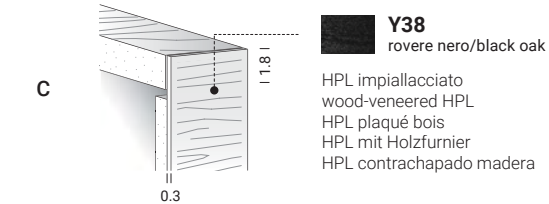
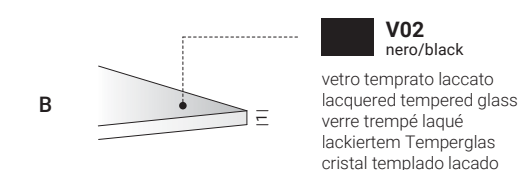
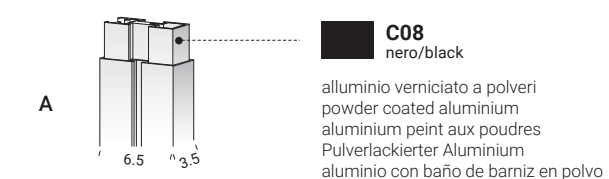
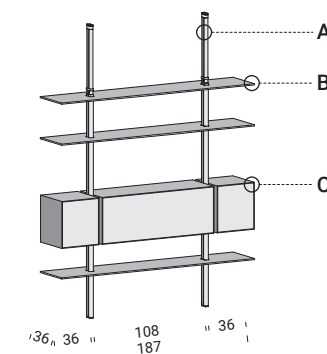

collection info
pg. 92



system
SY02

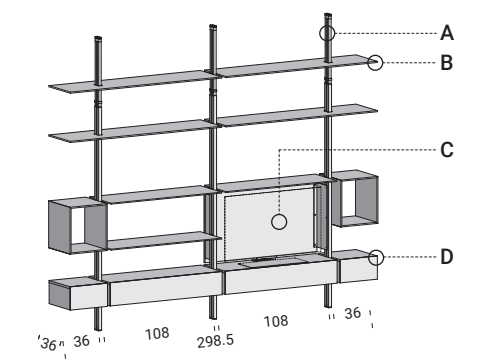

- A**

C21
seta/silk
alluminio verniciato a polveri
powder coated aluminium
aluminium peint aux poudres
Pulverlackierter Aluminium
aluminio con baño de barniz en polvo
- B**

V16
corda/ecru
vetro temprato laccato
lacquered tempered glass
verre trempé laqué
lackiertem Temperglas
cristal templado lacado
- C**

Q17
corda/ecru
agglomerato ligneo
wood composite
aggloméré de bois
holzartiges Agglomerat
aglomerado de madera
- D**

Y38
rovere nero/black oak
HPL impiallacciato
wood-veneered HPL
HPL plaqué bois
HPL mit Holz furnier
HPL contrachapado madera

collection info
pg. 92





system
SY52

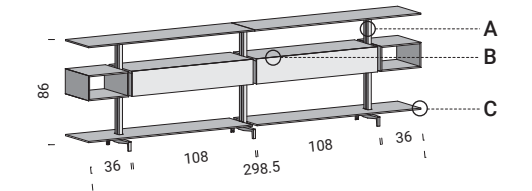

A

C08
nero/black

alluminio verniciato a polveri
powder coated aluminium
aluminium peint aux poudres
Pulverlackierter Aluminium
aluminio con baño de barniz en polvo

B

Q04
nero/black

vetro temprato laccato
lacquered tempered glass
verre trempé laqué
lackiertem Temperglas
cristal templado lacado

C

V02
nero/black

vetro temprato laccato
lacquered tempered glass
verre trempé laqué
lackiertem Temperglas
cristal templado lacado

collection info
pg. 92



system
SY53

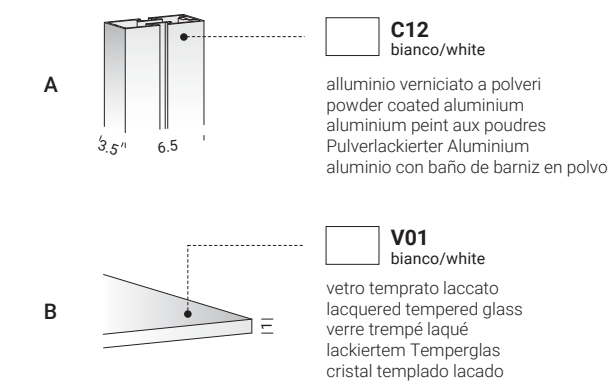
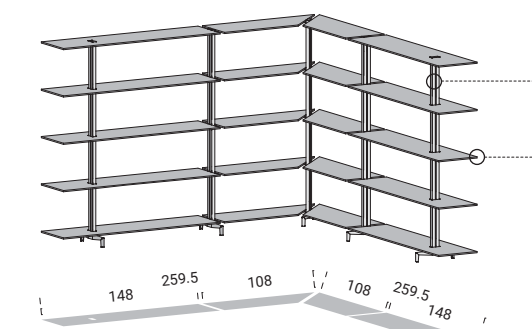

collection info
pg. 92

tables and coffee tables



balance

pg. 118

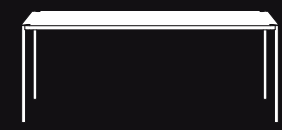

danske T

pg. 194



spillo

pg. 134



hammer

pg. 200



sintesi

pg. 152



mr. hyde

pg. 210

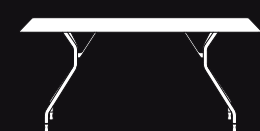

T7

pg. 168



spillo

pg. 150



T8

pg. 174



déco

pg. 220



IPE

pg. 186

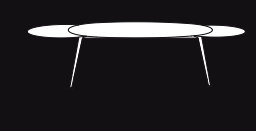

mr.hyde

pg. 216





balance

Il supporto in acciaio dei tavoli balance costituisce la base di un sistema di telai in grado di adattarsi in modo armonico e proporzionato a tutte le geometrie dei top disponibili. La sezione triangolare deriva dalla compressione di tubi a sezione circolare in acciaio, tale compressione aumenta la resistenza del supporto, conferendogli una silhouette elegante e leggera.

The steel support of the Balance tables forms the base of a frame system capable of easily adapting to all the geometries of the tops available. The triangular section comes from compressing circular steel tubes. Such compression increases the strength of the support, giving it an elegant and light silhouette.

Le support en acier des tables balance constitue la base d'un système de structures en mesure de s'adapter de manière harmonieuse et proportionnée à toutes les géométries des plateaux disponibles. La section triangulaire dérive de la compression de tubes à section circulaire en acier, cette compression augmente la résistance du support en lui conférant une silhouette élégante et légère.

Die Stahlbeine der Tische balance bilden die Basis eines Rahmensystems, das sich allen Formen der angebotenen Abschlussborde harmonisch und proportioniert anpasst. Der dreieckige Querschnitt entsteht aus dem Druck der Stahlrohre mit rundem Querschnitt. Dieser Druck erhöht die Festigkeit des Halters und verleiht ihm eine elegante und leichte Silhouette.

El soporte de acero de las mesas Balance constituye la base de un sistema de bastidores que puede adaptarse armoniosamente proporcionado sobres disponibles para todo tipo de geometría. La sección triangular deriva de la compresión de tubos de acero de sección circular. Dicha compresión aumenta la resistencia del soporte, confiriéndole una silueta elegante y ligera.



materiali / materials

legno massiccio
solid wood
bois massif
Massivholz
madera maciza

HPL+legno
HPL+wood
HPL+bois
HPL+Holz
HPL+madera

HPL

acciaio
steel
acier
Stahl
acero

Le materie prime che costituiscono il sistema balance derivano da un processo di riutilizzo e sono a loro volta riciclabili.

The primary materials used in the system balance are sourced from a reuse process, and are in turn recyclable.

Les matières premières qui composent le système balance dérivent d'un processus de réutilisation et sont à leur tour recyclables.

Die Rohstoffe für das System balance entstammen einem Wiederverwertungsprozess und sind Ihrerseits wiederum recyclebar.

Las materias primas que constituyen el sistema balance proceden de un proceso de reutilización y son, a su vez, reciclables.



disponibili riduzioni a misura
tailor-made reduction available
disponibles réductions sur mesure
Verkleinerung nach Kundenwunsch
Disponibles reducciones a medida

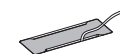

passacavo disponibile per tutti i top
cable gland available for all tops
passe-câble disponible pour tous les plateaux
Kabeldurchlass für alle Abschlussborde verfügbar
pasacables disponible para todos los sobres



iroko outdoor trattato ad olio 100% vegetale
Iroko outdoor treated with 100% vegetable oil
Iroko outdoor traité à l'huile 100% végétale
Iroko Outdoor behandelt mit 100% pflanzlichem Öl
Iroko para exteriores, tratado con aceite 100% vegetal

finiture / finishes

top tavolo / table top / plateaux de table / Tischplatte / plano de mesa

legno massiccio
solid wood
bois massif
Massivholz
madera maciza

T01 rovere oak
T02 noce walnut
T03 iroko
T04 iroko outdoor

HPL
FENIX NTM®
FENIX NTM®

L03 bianco white
L08 grigio Londra London grey
L06 nero black

HPL + legno/wood
bois/Holz
madera

Y36 rovere oak
Y34 noce walnut
Y37 rovere affumicato smoked oak
Y39 frassino nero black ash

HPL + ottone/brass
laiton/Messing
latón

C31 ottone brass

eco-touch

N01 sabbia sand

eco-touch

N02 basalto basalt

telaio / structure / châssis / Gestell / bastidor

acciaio verniciato
painted steel
acier peint
lackierter Stahl
acero pintado

C12 bianco white
C21 seta silk
C23 corda ecru
C30 ghisa cast-iron
C14 antracite anthracite
C08 nero black
C18 verde green
C26 corten corten
C29 bronzo bronze

uso in esterno
full outdoor use
uso in esterno riparato
protected outdoor use

dimensioni / dimensions

tavoli / tables / tables / Tische / mesas

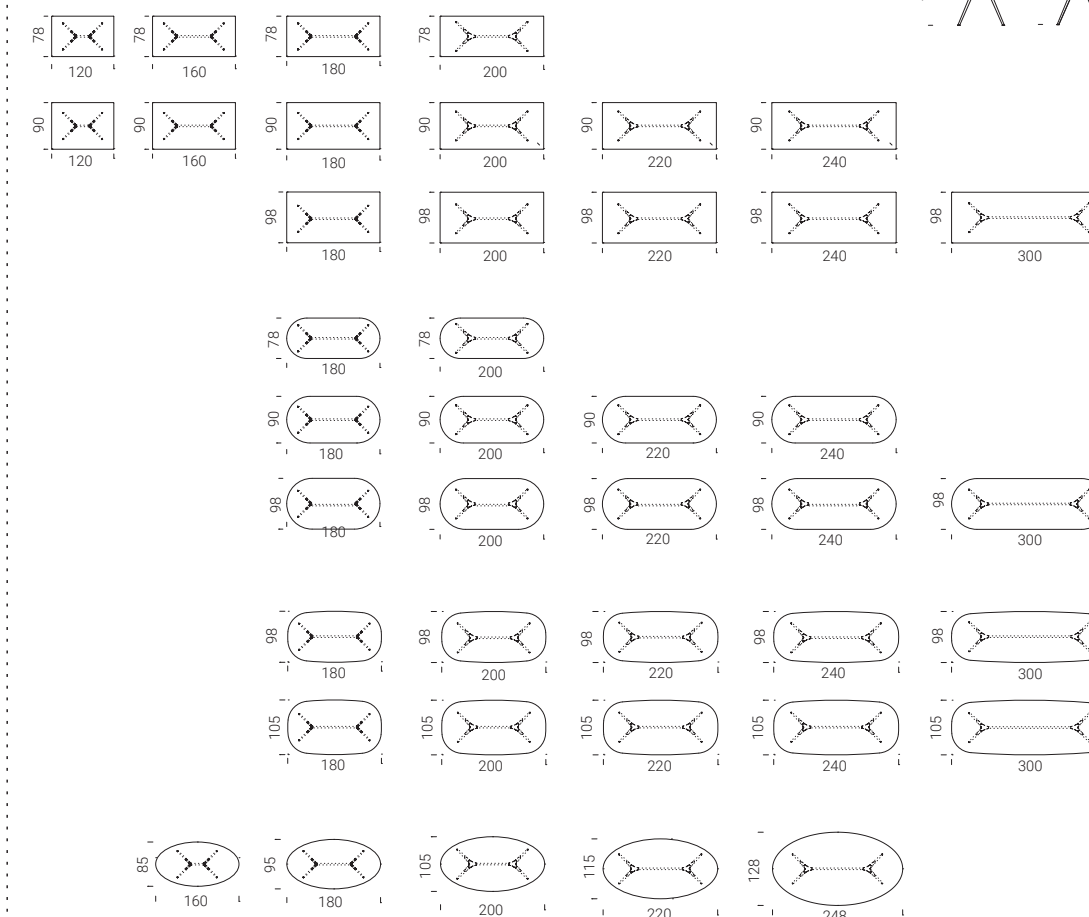

alcuni tavoli sono realizzabili con altezza h=95 cm: verificarne a listino la disponibilità / Some of the tables can be produced at a height of 95 cm: check the relative availability in the catalogue / certaines tables sont réalisées avec une hauteur h=95 cm: vérifier sur le catalogue leur disponibilité / Einige Tische können mit einer Höhe von h=95 cm gefertigt werden: Siehe Preisliste / algunas mesas se pueden realizar con altura h=95cm: averiguar disponibilidad en la lista

scrivtoi / writing desks / secrétaires / Schreibtischen / escritorios

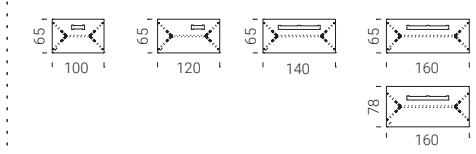

verificare a listino geometrie e finiture / check profiles and finishings in the price list / vérifier sur la liste de prix les géométries et les finitions / Siehe Preisliste für Ausführungen und Oberflächen / averiguar geometrías y acabados en la lista



balance
BA08

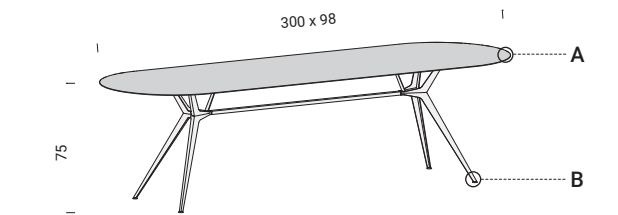

N02
basalto/basalt
HPL **eco-touch**



C30
ghisa/cast-iron
acciaio verniciato a polveri
powder coated steel
acier peint aux poudres
Pulverlackierter Stahl
Acero con baño de barniz en polvo

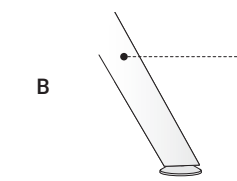

collection info
pg. 118



balance
BA02

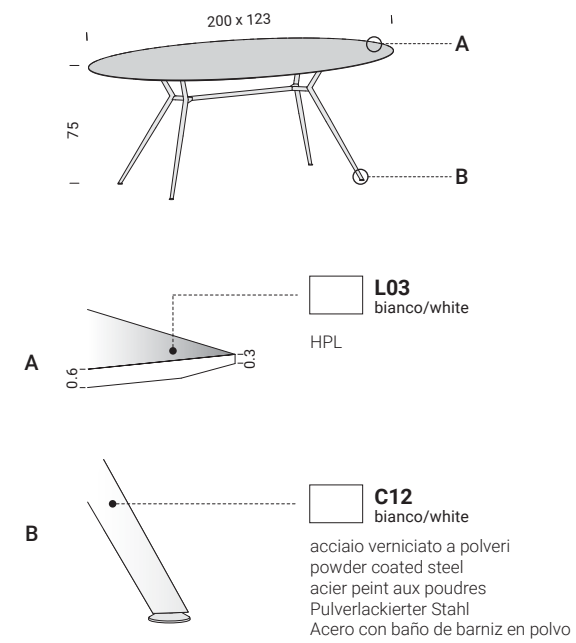

collection info
pg. 118



balance
BA03

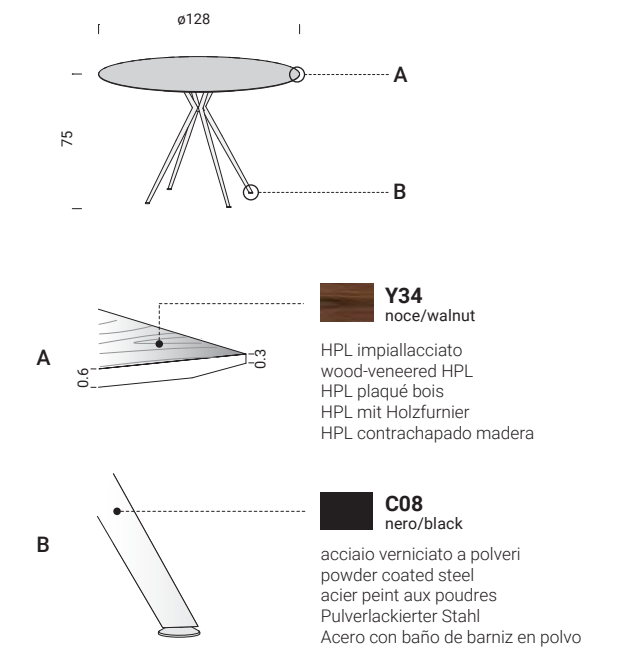

collection info
pg. 118



balance
BA01

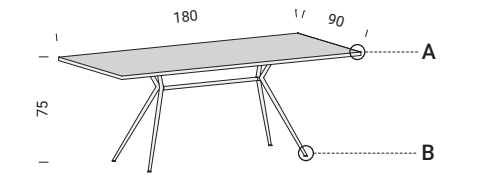

- A**
- T01**
rovere/oak
- legno massiccio
solid wood
bois massif
Massivholz
madera maciza
- B**
- C08**
nero/black
- acciaio verniciato a polveri
powder coated steel
acier peint aux poudres
Pulverlackierter Stahl
Acero con baño de barniz en polvo

collection info
pg. 118



balance
BA04

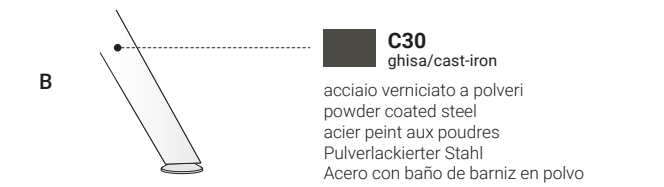
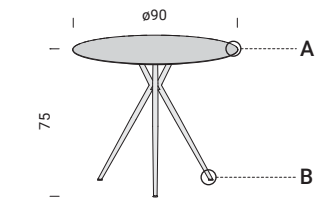

collection info
pg. 118



balance
BA06

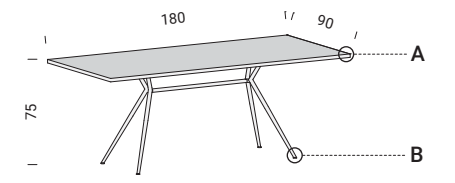

- A**

T04
iroko outdoor

legno massiccio
solid wood
bois massif
Massivholz
madera maciza
- B**

C26
corten

acciaio verniciato a polveri
powder coated steel
acier peint aux poudres
Pulverlackierter Stahl
Acero con baño de barniz en polvo

collection info
pg. 118

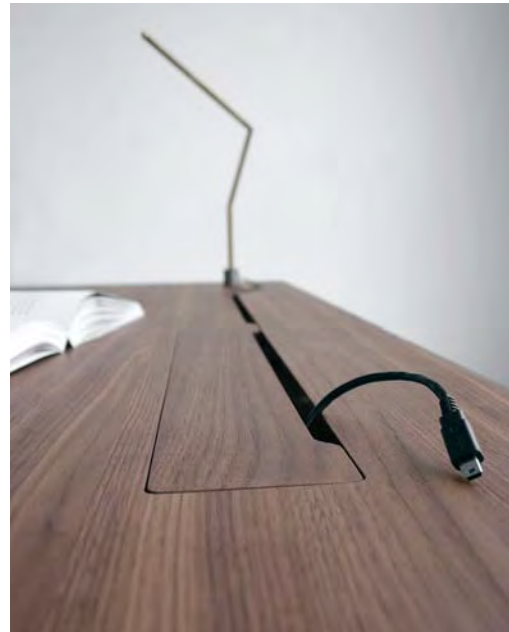

balance
BA05

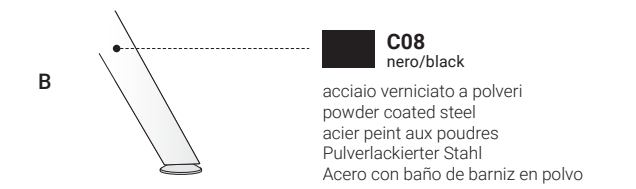
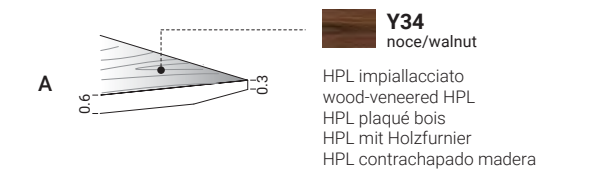
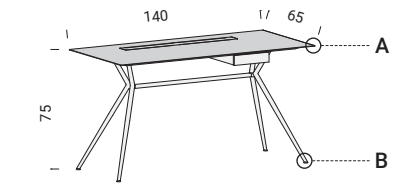

collection info
pg. 118

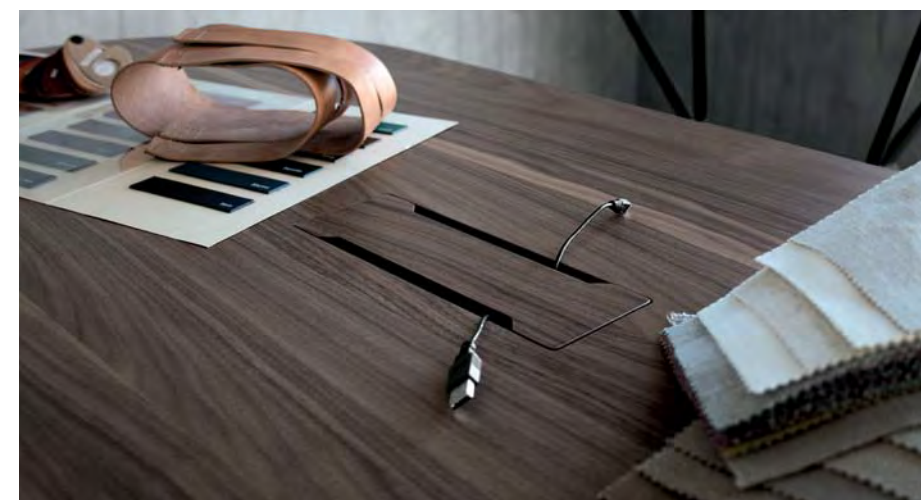

balance

BA07

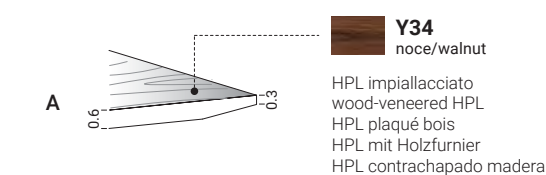
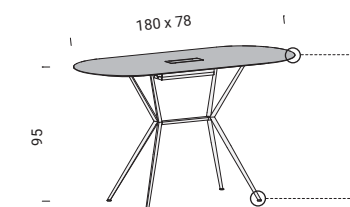

Y34
noce/walnut

HPL impiallacciato
wood-veneered HPL
HPL plaqué bois
HPL mit Holzfurnier
HPL contrachapado madera

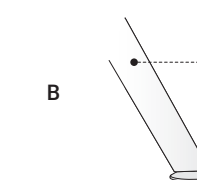

C08
nero/black

acciaio verniciato a polveri
powder coated steel
acier peint aux poudres
Pulverlackierter Stahl
Acero con baño de barniz en polvo

collection info
pg. 118



spillo

Spillo è un tavolo dai minimi ingombri volumetrici, il top in HPL ha un bordo perimetrale visibile di soli 3mm. Il telaio in acciaio sottostante ha geometrie che massimizzano la resistenza e la rigidità del top, consentendo lunghezze sino a 300 cm. Il telaio ed i supporti a forma conica in acciaio costituiscono un insieme della massima leggerezza volumetrica.

The Spillo table offers minimum volume. The HPL top has a visible perimeter edge of just 3 mm. The underneath steel frame has geometries to maximise the strength and sturdiness of the top, allowing lengths up to 300 cm. The frame and the supports, which are made of steel and conical in shape, give an overall maximum volumetric lightness.

Spillo est une table présentant un encombrement volumétrique minimum, le plateau en HPL a un bord périphérique visible de 3mm seulement. La structure inférieure en acier présente des géométries qui augmentent au maximum la résistance et la rigidité du plateau, permettant des longueurs allant jusqu'à 300 cm. La structure et les supports de forme conique en acier constituent un ensemble de la plus grande légèreté volumétrique.

Spillo ist ein Tisch mit einem minimalem Platzbedarf, das Abschlussbord aus HPL hat eine sichtbare Kontourführung von nur 3 mm. Die Geometrien des darunter liegenden Rahmens aus Stahl maximieren die Widerstandsfähigkeit und Steifheit des Abschlussbords und ermöglichen somit Längen von bis zu 300 cm. Die Rahmen und konischen Stützen aus Stahl bilden eine Einheit mit maximaler, volumetrischer Leichtigkeit.

Spillo es una mesa de dimensiones volumétricas mínimas. El sobre de HPL tiene un borde perimetral visible de solo 3 mm. El bastidor inferior de acero posee unas geometrías que maximizan la resistencia y la rigidez del sobre, permitiendo longitudes de hasta 300 cm. El bastidor y los soportes cónicos de acero componen un conjunto de máxima ligereza volumétrica.

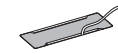

passacavo disponibile per tutti i top
cable gland available for all tops
passe-câble disponible pour tous les plateaux
Kabeldurchlass für alle Abschlussborde verfügbar
pasacables disponible para todos los sobres

materiali / materials



HPL+legno
HPL+wood
HPL+bois
HPL+Holz
HPL+madera



HPL



acciaio
steel
acier
Stahl
acero

Le materie prime che costituiscono il sistema spillo derivano da un processo di riutilizzo e sono a loro volta riciclabili.

The primary materials used in the system spillo are sourced from a reuse process, and are in turn recyclable.

Les matières premières qui composent le système spillo dérivent d'un processus de réutilisation et sont à leur tour recyclables.

Die Rohstoffe für das System spillo entstammen einem Wiederverwertungsprozess und sind Ihrerseits wiederum recyclebar.

Las materias primas que constituyen el sistema spillo proceden de un proceso de reutilización y son, a su vez, reciclables.

finiture / finishes

top tavolo / table top / plateau de table / Tischplatte / plano de mesa

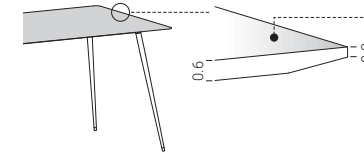

HPL	L03	bianco white	
FENIX NTM [®]	L08	grigio Londra London grey	
FENIX NTM [®]	L06	nero black	
HPL + legno/wood bois/Holz madera	Y36	rovere oak	
	Y34	noce walnut	
	Y37	rovere affumicato smoked oak	
	Y39	frassino nero black ash	
HPL + ottone/brass laiton/Messing latón	C31	ottone brass	
eco-touch	N01	sabbia sand	
eco-touch	N02	basalto basalt	

telaio / structure / châssis / Gestell / bastidor

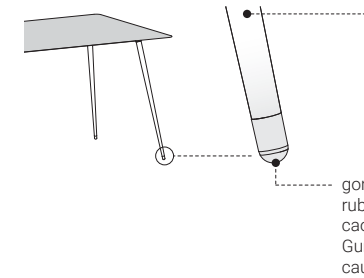

acciaio verniciato painted steel acier peint lackierter Stahl acero pintado	C12	bianco white	
	C21	seta silk	
	C23	corda ecrú	
	C30	ghisa cast-iron	
	C14	antracite anthracite	
	C08	nero black	
	C18	verde green	
	C26	corten	
	C29	bronzo bronze	

uso in esterno
full outdoor use

dimensioni / dimensions

tavoli / tables / tables / Tische / mesas

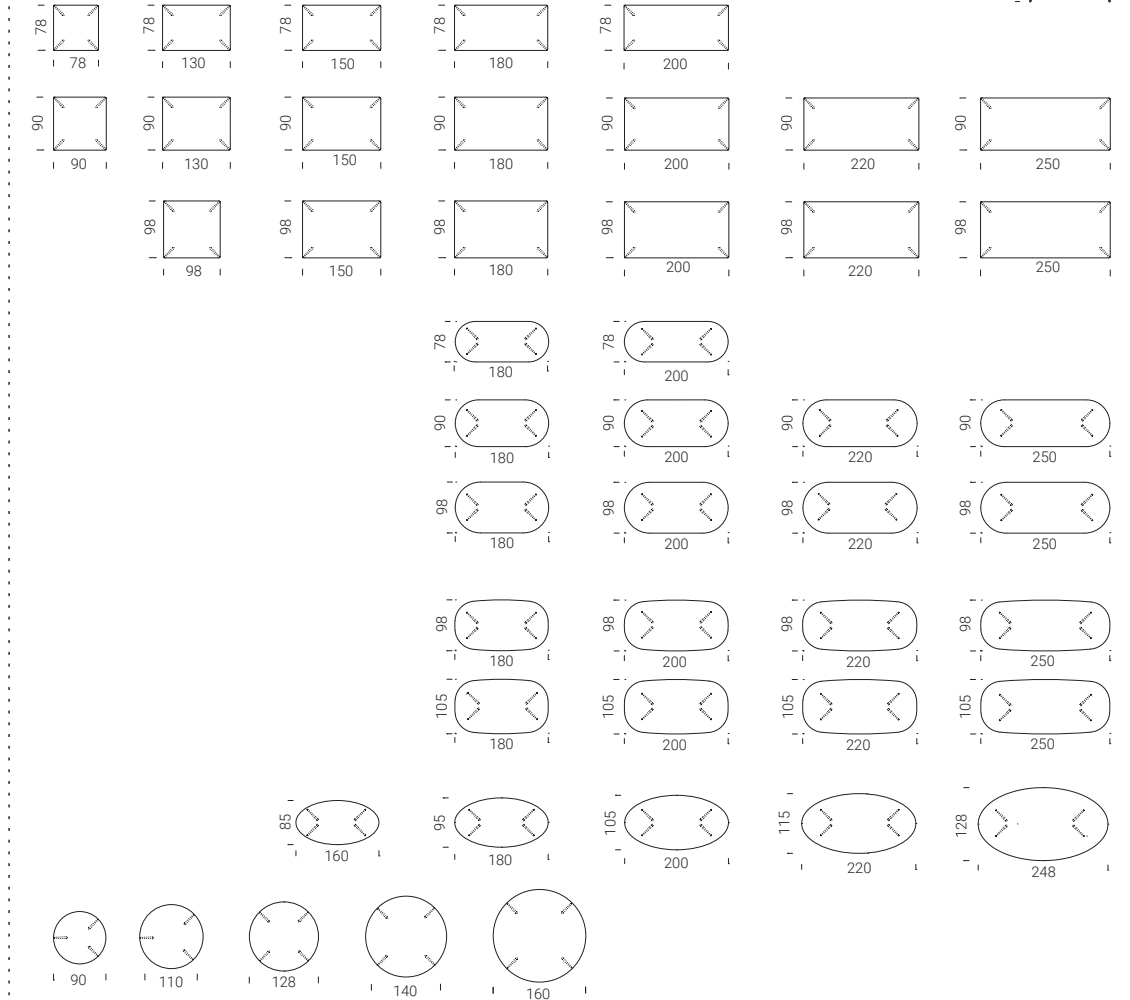

tavoli bassi / coffee tables / tables basses / Couchtische / mesas bajas



tavoli bassi / coffee tables / tables basses / Couchtische / mesas bajas

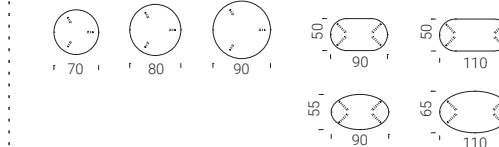

verificare a listino geometrie e finiture / check profiles and finishings in the price list / vérifier sur la liste de prix les géométries et les finitions / Siehe Preisliste für Ausführungen und Oberflächen / averiguar geometrías y acabados en la lista



spillo
SP24

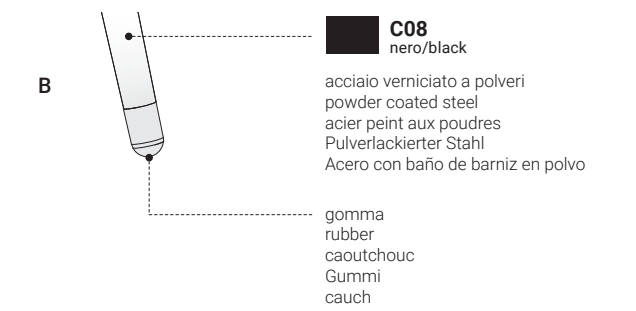
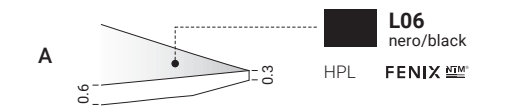
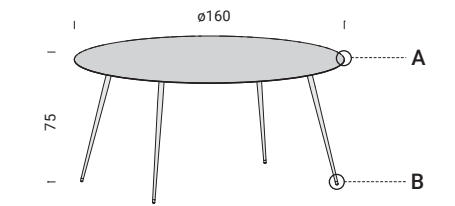

collection info
pg. 134



spillo
SP21

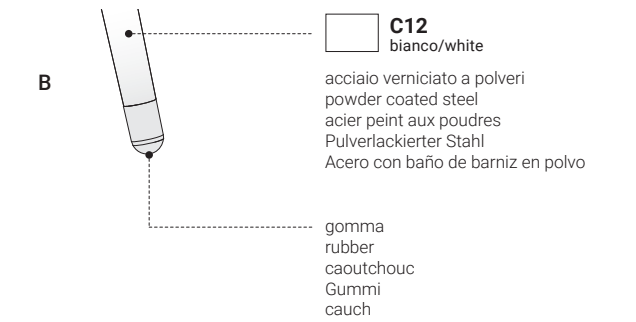
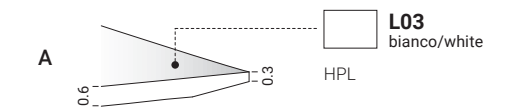
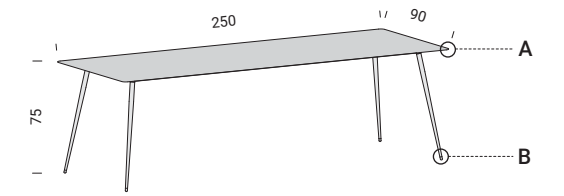

collection info
pg. 134



spillo
SP05

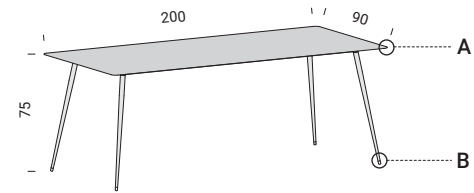

A

Y36
rovere/oak

HPL impiallacciato
wood-veneered HPL
HPL plaqué bois
HPL mit Holz furnier
HPL contrachapado madera

B

C30
ghisa/cast-iron

acciaio verniciato a polveri
powder coated steel
acier peint aux poudres
Pulverlackierter Stahl
Acero con baño de barniz en polvo

gomma
rubber
caoutchouc
Gummi
cauch

collection info
pg. 134



spillo
SP20

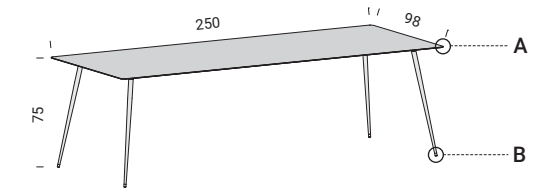

A

N01
sabbia/sand

HPL **eco-touch**

B

C08
nero/black

acciaio verniciato a polveri
powder coated steel
acier peint aux poudres
Pulverlackierter Stahl
Acero con baño de barniz en polvo

gomma
rubber
caoutchouc
Gummi
cauch

collection info
pg. 134





spillo
SP25

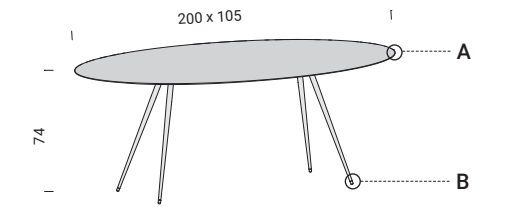

A

Y39
frassino nero/black ash

HPL impiallacciato
wood-veneered HPL
HPL plaqué bois
HPL mit Holz furnier
HPL contrachapado madera

B

C08
nero/black

acciaio verniciato a polveri
powder coated steel
acier peint aux poudres
Pulverlackierter Stahl
Acero con baño de barniz en polvo

gomma
rubber
caoutchouc
Gummi
cauch

collection info
pg. 134



spillo
SP03

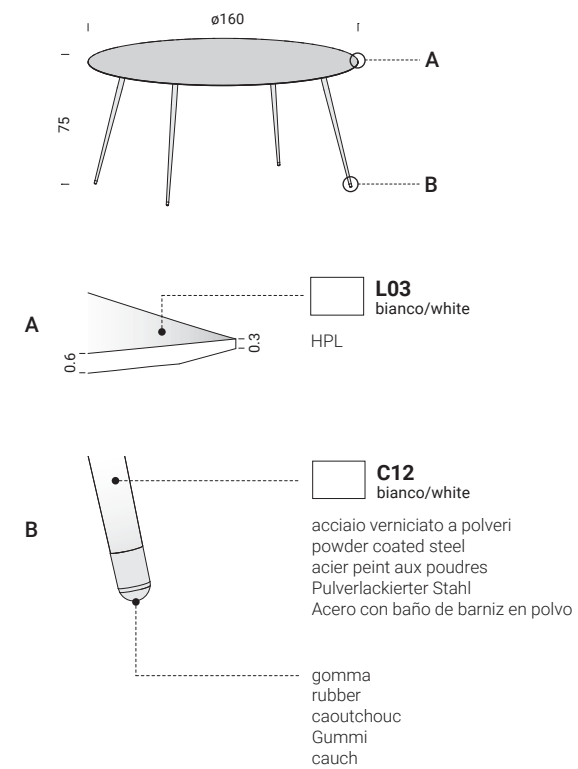

collection info
pg. 134



spillo
SP19

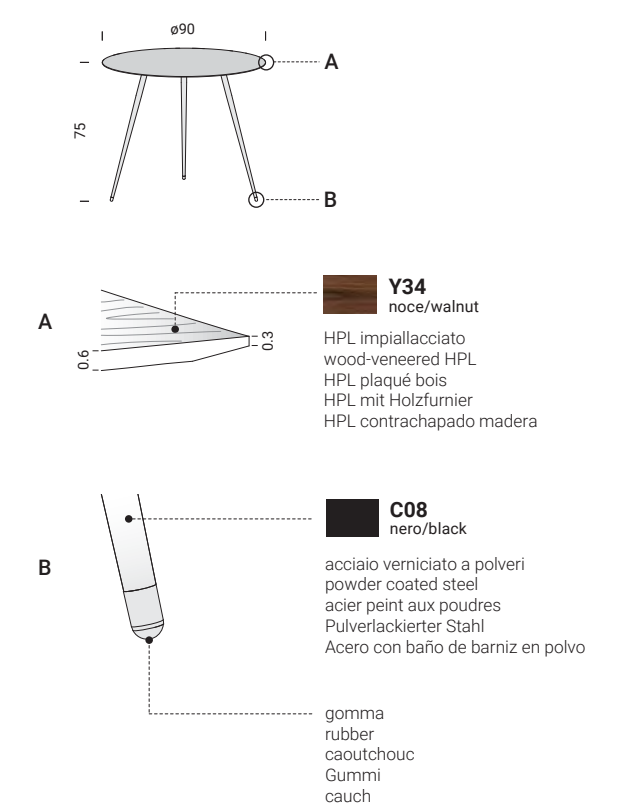

collection info
pg. 134

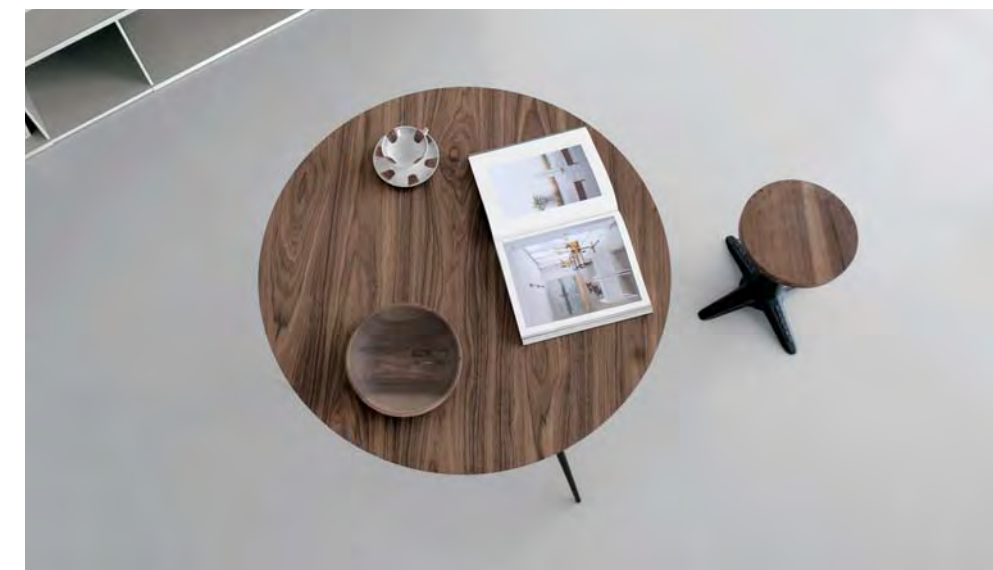



spillo
SP22

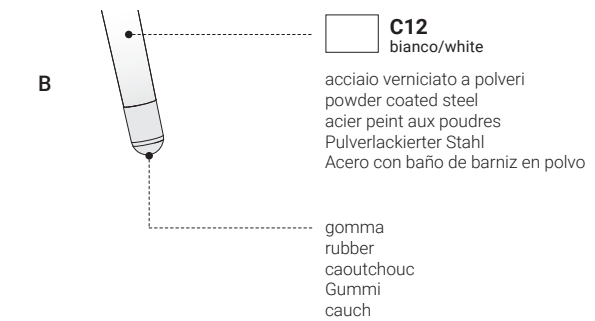
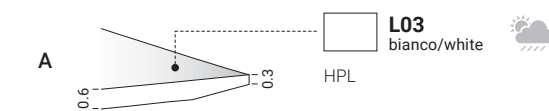
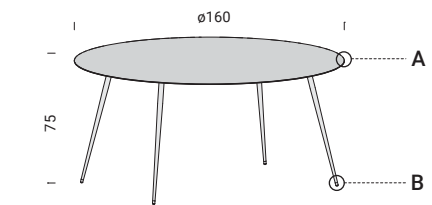

collection info
pg. 134

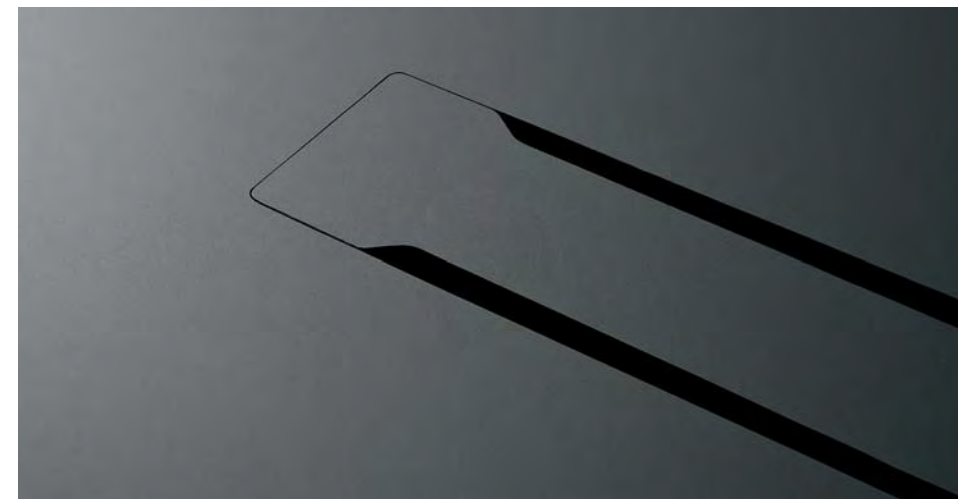

spillo
SP04

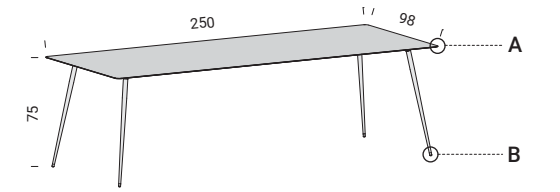

L06
nero/black
HPL **FENIX** ^{MM}

C08
nero/black
acciaio verniciato a polveri
powder coated steel
acier peint aux poudres
Pulverlackierter Stahl
Acero con baño de barniz en polvo

gomma
rubber
caoutchouc
Gummi
cauch

collection info
pg. 134



spillo
SP26

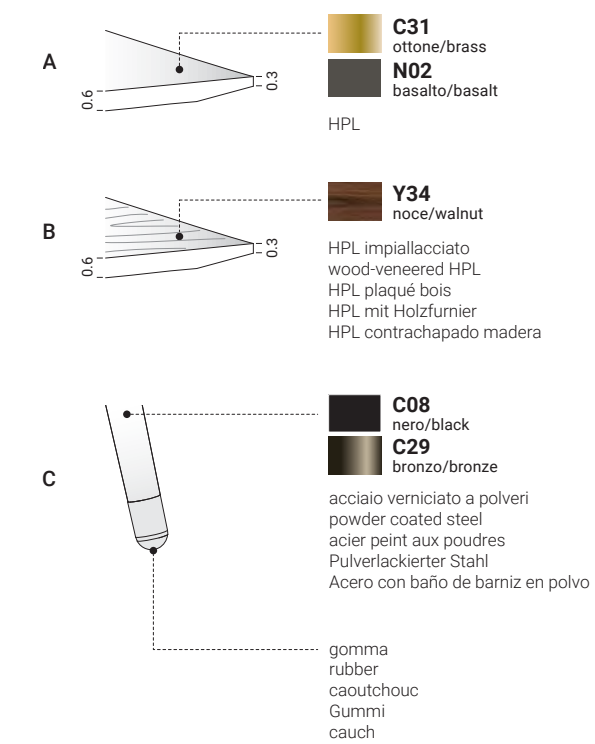
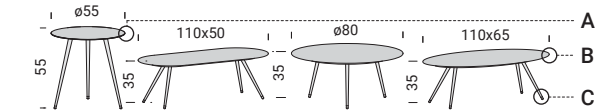

collection info
pg. 134



sintesi

Semplicità costruttiva ed essenza dei materiali danno vita al tavolo allungabile "sintesi". Il telaio è in acciaio per consentire sezioni ribassate e mantenere performance di allungo sino a 300 cm. Il top è in HPL e i componenti interni sono in alluminio, ottone e acciaio inox, ciò rende compatibile il tavolo anche in outdoor.

Simple construction and the essence of materials bringing a "Sintesi" extendable table to life. The steel frame allows for lowered sections and maintains performance up to a length of 300 cm. The top is in HPL and the inner parts are in aluminium, brass and stainless steel, making the table compact for outdoor use.

La simplicité de construction et l'essence des matériaux donnent le jour à la table à rallonges "sintesi". La structure est en acier pour permettre des sections surbaissées et maintenir une performance d'allongement jusqu'à 300 cm. Le plateau est en HPL et les composants internes sont en aluminium, laiton et acier inox, ce qui rend la table compatible pour utilisation également en extérieur.

Die einfache Konstruktion und das Wesentliche der Materialien sind kennzeichnend für den ausziehbaren Tisch „sintesi“. Der Rahmen ist aus Stahl, um abgeflachte Querschnitte und Längen von max. 300 cm zu ermöglichen. Das Abschlussbord ist aus HPL und die Innenteile sind aus Aluminium, Messing und Edelstahl, dadurch ist der Tisch auch für Outdoor geeignet.

Su construcción sencilla y la esencia de sus materiales dan vida a la mesa extensible "Sintesi". El bastidor es de acero para permitir secciones rebajadas y mantener su capacidad de extensión hasta 300 cm. El sobre es de HPL y los componentes interiores son de aluminio, latón y acero inoxidable, lo que hace que la mesa también se pueda usar en el exterior.



possibilità di affiancamento / possibility to place side by side / possibilité d'association / Aufstellung nebeneinander möglich / posibilidad de colocarse uno al lado del otro

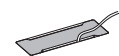

passacavo disponibile per tutti i top / cable gland available for all tops / passe-câble disponible pour tous les plateaux / Kabeldurchlass für alle Abschlussborde verfügbar / pasacables disponible para todos los sobres



iroko outdoor trattato ad olio 100% vegetale / Iroko outdoor treated with 100% vegetable oil / Iroko outdoor traité à l'huile 100% végétale / Iroko Outdoor behandelt mit 100% pflanzlichem Öl / Iroko para exteriores, tratado con aceite 100% vegetal

materiali / materials



legno massiccio
solid wood
bois massif
Massivholz
madera maciza



HPL+legno
HPL+wood
HPL+bois
HPL+Holz
HPL+madera



HPL



acciaio
steel
acier
Stahl
acero

Le materie prime che costituiscono il sistema sintesi derivano da un processo di riutilizzo e sono a loro volta riciclabili.

The primary materials used in the system sintesi are sourced from a reuse process, and are in turn recyclable.

Les matières premières qui composent le système sintesi dérivent d'un processus de réutilisation et sont à leur tour recyclables.

Die Rohstoffe für das System sintesi entstammen einem Wiederverwertungsprozess und sind ihrerseits wiederum recyclebar.

Las materias primas que constituyen el sistema sintesi proceden de un proceso de reutilización y son, a su vez, reciclables.

finiture / finishes

top tavolo / table top / plateau de table / Tischplatte / plano de mesa

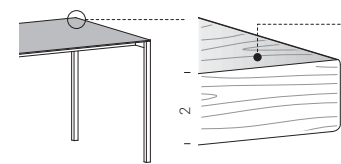

legno massiccio
solid wood
bois massif
Massivholz
madera maciza

- T01** rovere oak
- T02** noce walnut
- T03** iroko
- T04** iroko outdoor

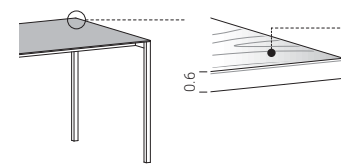

HPL

FENIX NTM

FENIX NTM

- L03** bianco white
- L08** grigio Londra London grey
- L06** nero black

HPL + legno/wood
bois/Holz
madera

- Y36** rovere oak
- Y34** noce walnut
- Y37** rovere affumicato smoked oak
- Y39** frassino nero black ash

HPL + ottone/brass
laiton/Messing
latón

- C31** ottone brass

eco-touch

- N01** sabbia sand

eco-touch

- N02** basalto basalt

telaio / structure / châssis / Gestell / bastidor

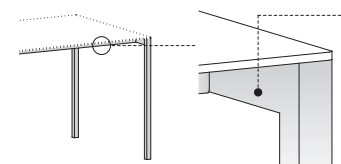

acciaio verniciato
painted steel
acier peint
lackierter Stahl
acero pintado

- C12** bianco white
- C21** seta silk
- C23** corda ecru
- C30** ghisa cast-iron
- C14** antracite anthracite
- C08** nero black
- C18** verde green
- C26** corten
- C29** bronzo bronze

uso in esterno
full outdoor use

uso in esterno riparato
protected outdoor use

dimensioni / dimensions

tavoli fissi / fixed tables / tables fixes / fester Tische / mesas fijas

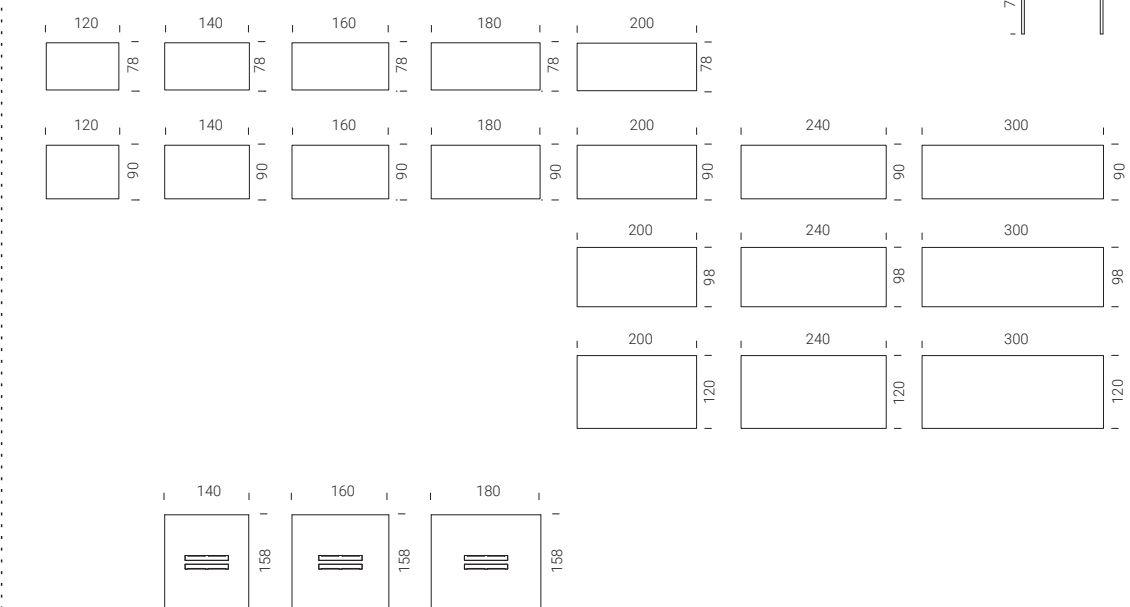

tavoli e panche allungabili / extendable tables and benches / tables et bancs extensibles / ausziehbare Tische und Bänke / mesas y banquillos extensibles

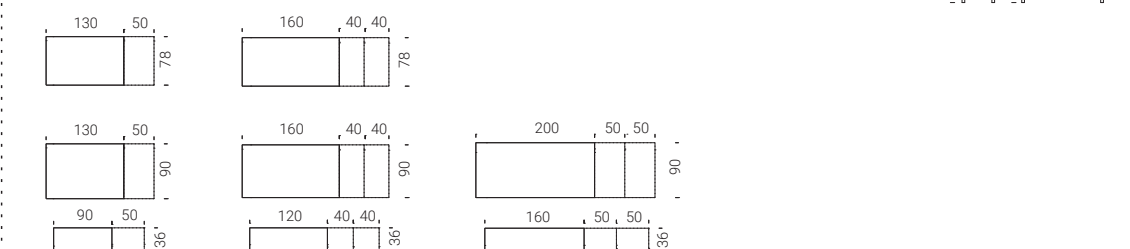

panche fisse / fixed benches / bancs fixes / Bänke, fest / banquillos fijos

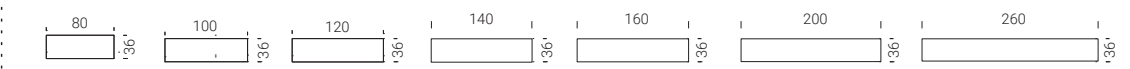

accessori / accessories / accessoires / Zubehör / accesorios

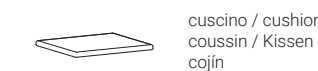

cuscino / cushion
cousin / Kissen
cojín



schienale / backrest
dossier / Rücken
respaldo

verificare a listino geometrie e finiture / check profiles and finishings in the price list / vérifier sur la liste de prix les géométries et les finitions / Siehe Preisliste für Ausführungen und Oberflächen / averiguar geometrias y acabados en la lista



sintesi
ST01

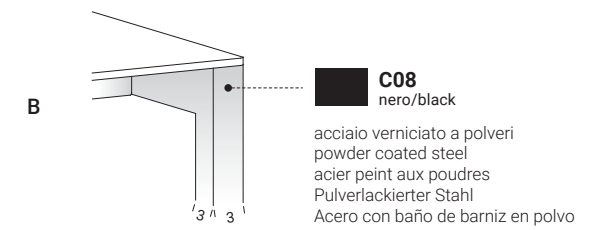
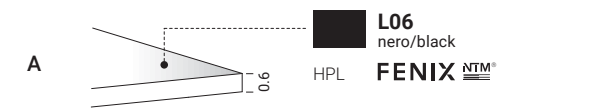
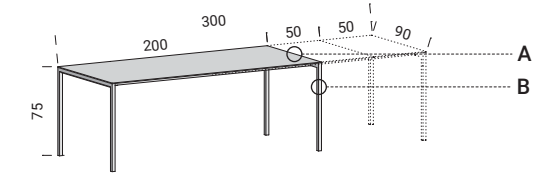

collection info
pg. 152

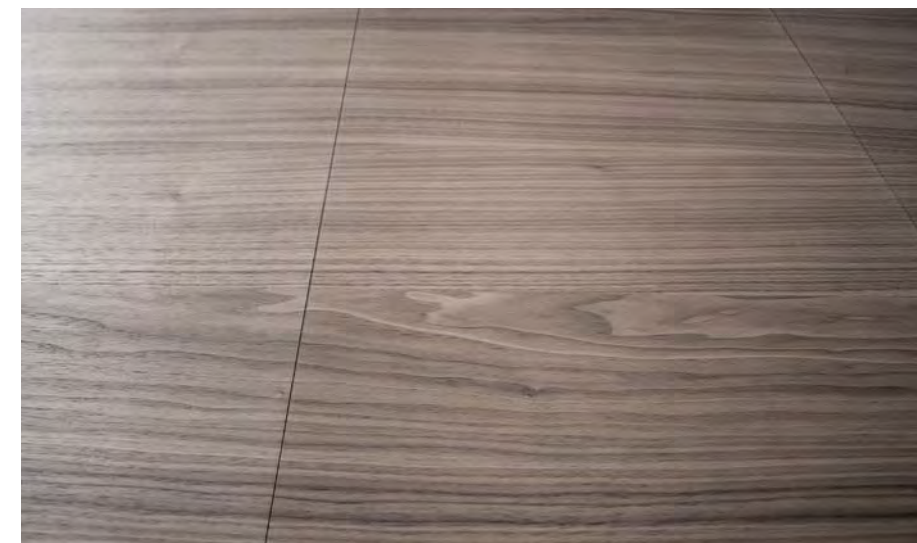

sintesi
ST02

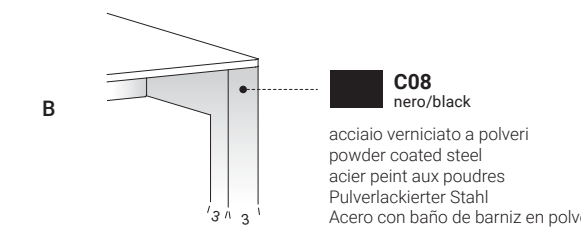
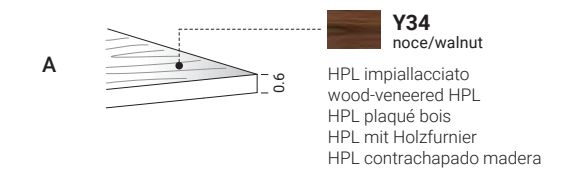
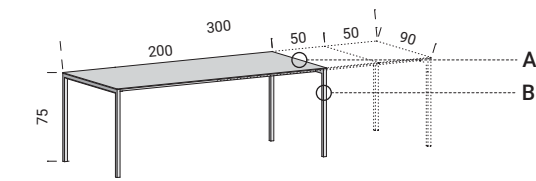

collection info
pg. 152



sintesi
ST06

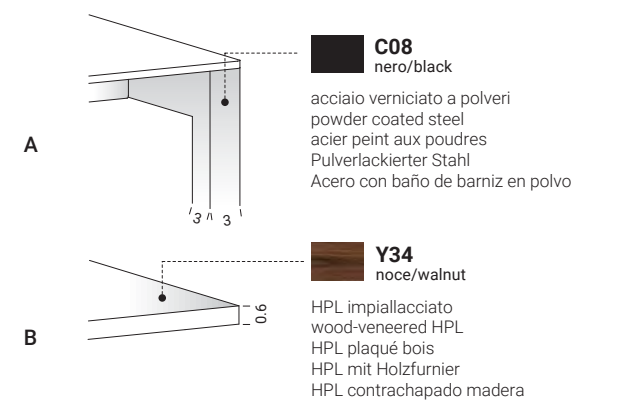
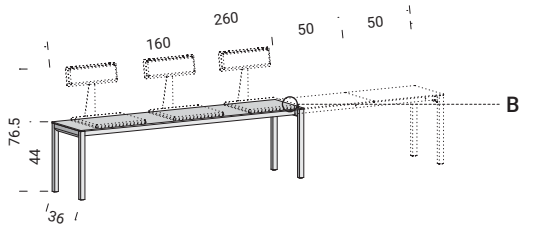
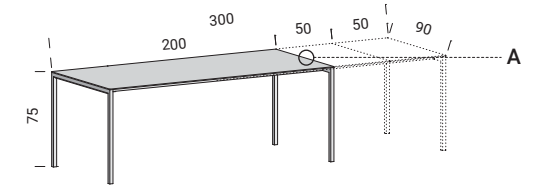

collection info
pg. 152





sintesi
ST03

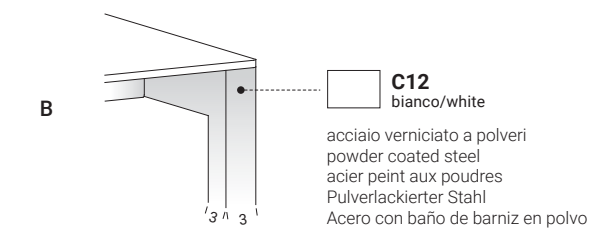
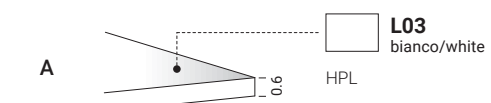
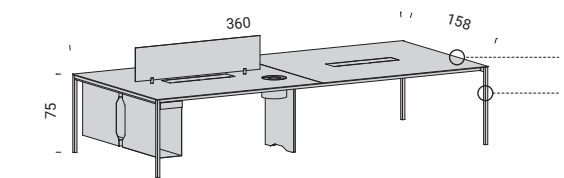

collection info
pg. 152





sintesi
ST04

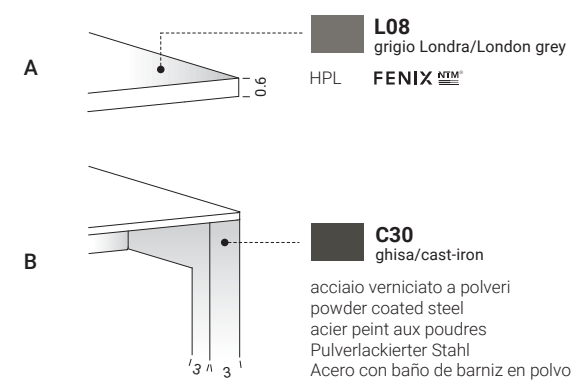
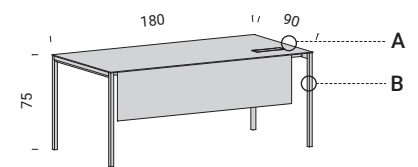

collection info
pg. 152



sintesi
ST05

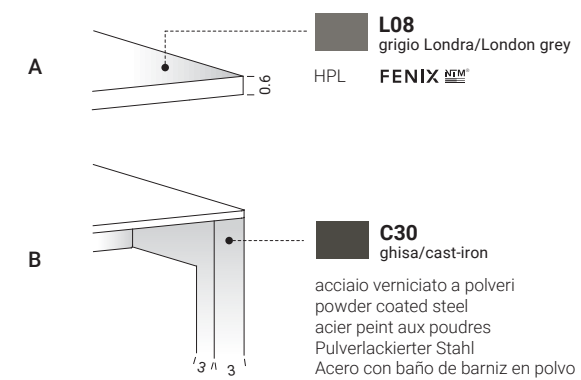
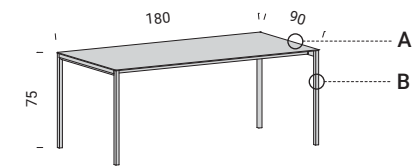

collection info
pg. 152

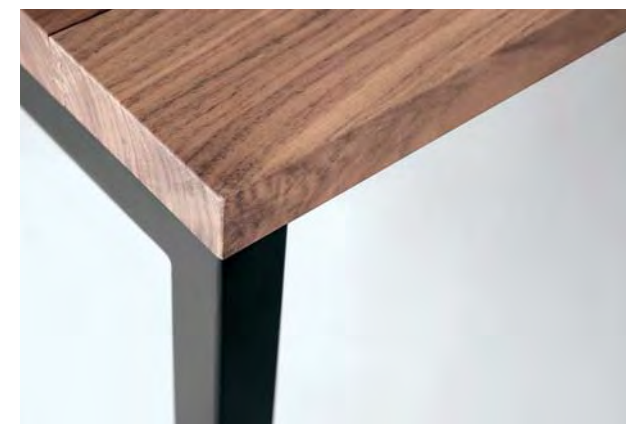



T7

Grazie alla tecnologia di piegatura tridimensionale dei profili è stato possibile realizzare un sistema tavoli che offre molteplici gradi di libertà. Il telaio leggero ma resistente supporta tavoli da 160 a 300cm di lunghezza, inoltre accoglie 5 tipologie di geometrie top e rende possibile anche la riduzione a misura.

Thanks to the 3D profile bending technology, it has been possible to create a table system that provides multiple degrees of freedom. The light yet resistant frame supports tables between 160 and 300cm long; moreover, it can accommodate 5 types table top profiles and makes custom reduction possible.

Grâce à la technologie de pliage tridimensionnel des profils, il a été possible de réaliser un système de tables qui offre de nombreux niveaux de liberté. Le châssis léger, mais résistant, supporte des tables de 160 à 300 cm de longueur, en outre il accueille 5 typologies de géométries de plateaux et permet aussi la réduction sur mesure.

Dank eines technologisch ausgefeilten, dreidimensionalen Biegeverfahrens erhält man Profile für ein Tischsystem mit einem breiten Spektrum an freien Gestaltungsmöglichkeiten. Leichte, formstabile Gestelle tragen Tischplatten von 160 bis 300 cm Länge, in fünf verschiedenen Ausformungen und Größen, wobei auch die Verkürzung nach Maß vorgesehen ist.

Gracias a la tecnología de doblado tridimensional de los perfiles, se ha podido realizar un sistema de mesas que ofrece múltiples niveles de libertad. El bastidor ligero pero resistente, soporta mesas de 160 a 300cm de largo; además, cuenta con 5 tipos de geometrías para la encimera y también permite la reducción a medida.



disponibili riduzioni a misura / tailor-made reduction available / disponibles réductions sur mesure / Verkleinerung nach Kundenwunsch / Disponibles reducciones a medida

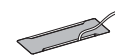

passacavo disponibile per tutti i top / cable gland available for all topspasse-câble disponible pour tous les plateaux / Kabeldurchlass für alle Abschlussborde verfügbar / pasacables disponible para todos los sobres



iroko outdoor trattato ad olio 100% vegetale / Iroko outdoor treated with 100% vegetable oil / Iroko outdoor traité à l'huile 100% végétale / Iroko Outdoor behandelt mit 100% pflanzlichem Öl / Iroko para exteriores, tratado con aceite 100% vegetal

materiali / materials



legno massiccio
solid wood bois
massif Massivholz
madera maciza



HPL



HPL+legno
HPL+wood
HPL+bois
HPL+Holz
HPL+madera



acciaio
steel
acier
Stahl
acero

Le materie prime che costituiscono il sistema T7 derivano da un processo di riutilizzo e sono a loro volta riciclabili.

The primary materials used in the system T7 are sourced from a reuse process, and are in turn recyclable.

Les matières premières qui composent le système T7 dérivent d'un processus de réutilisation et sont à leur tour recyclables.

Die Rohstoffe für das System T7 entstammen einem Wiederverwertungsprozess und sind ihrerseits wiederum recyclebar.

Las materias primas que constituyen el sistema T7 proceden de un proceso de reutilización y son, a su vez, reciclables.

finiture / finishes

top tavolo / table top / plateaux de table / Tischplatte / plano de mesa

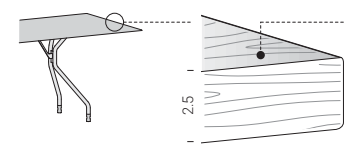

legno massiccio
solid wood
bois massif
Massivholz
madera maciza

- T01** rovere oak
- T02** noce walnut
- T03** iroko
- T04** iroko outdoor

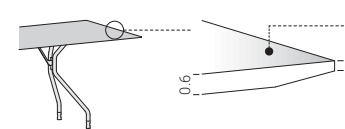

HPL
FENIX NTM[®]
FENIX NTM[®]

- L03** bianco white
- L08** grigio Londra London grey
- L06** nero black
- Y36** rovere oak
- Y34** noce walnut
- Y37** rovere affumicato smoked oak
- Y39** frassino nero black ash

HPL + legno/wood
bois/Holz
madera

HPL + ottone/brass
laiton/Messing
latón

- eco-touch** **C31** ottone brass
- eco-touch** **N01** sabbia sand
- eco-touch** **N02** basalto basalt

telaio / structure / châssis / Gestell / bastidor

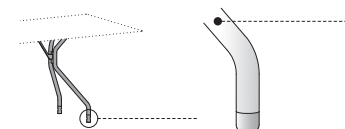

acciaio verniciato
painted steel
acier peint
lackierter Stahl
acero pintado

- C12** bianco white
- C21** seta silk
- C23** corda ecrú
- C30** ghisa cast-iron
- C14** antracite anthracite
- C08** nero black
- C18** verde green
- C26** corten
- C29** bronzo bronze

- uso in esterno full outdoor use
- uso in esterno riparato protected outdoor use

dimensioni / dimensions

tavoli / tables / tables / Tische / mesas

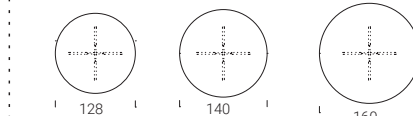
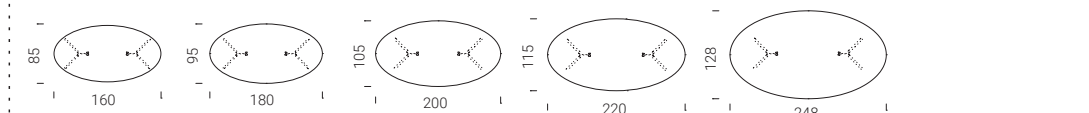
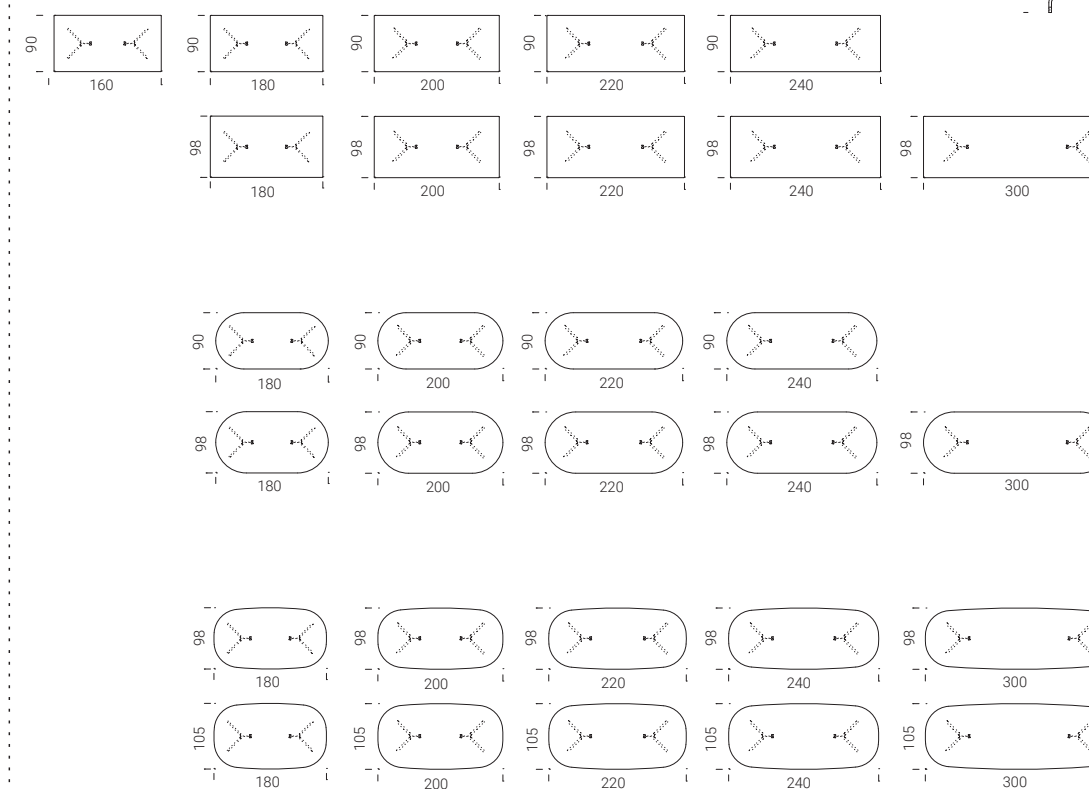

verificare a listino geometrie e finiture / check profiles and finishings in the price list / vérifier sur la liste de prix les géométries et les finitions / Siehe Preisliste für Ausführungen und Oberflächen / averiguar geometrías y acabados en la lista



T7
T701

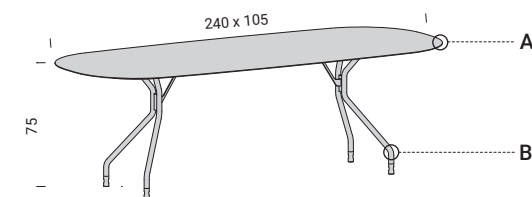

A

Y37
rovere affumicato/smoked oak

HPL impiallacciato
wood-veneered HPL
HPL plaqué bois
HPL mit Holz furnier
HPL contrachapado madera

B

C29
bronzo/bronze

acciaio verniciato a polveri
powder coated steel
acier peint aux poudres
Pulverlackierter Stahl
Acero con baño de barniz en polvo

ottone
brass
laiton
Messing
latón

collection info
pg. 168



T7
T702

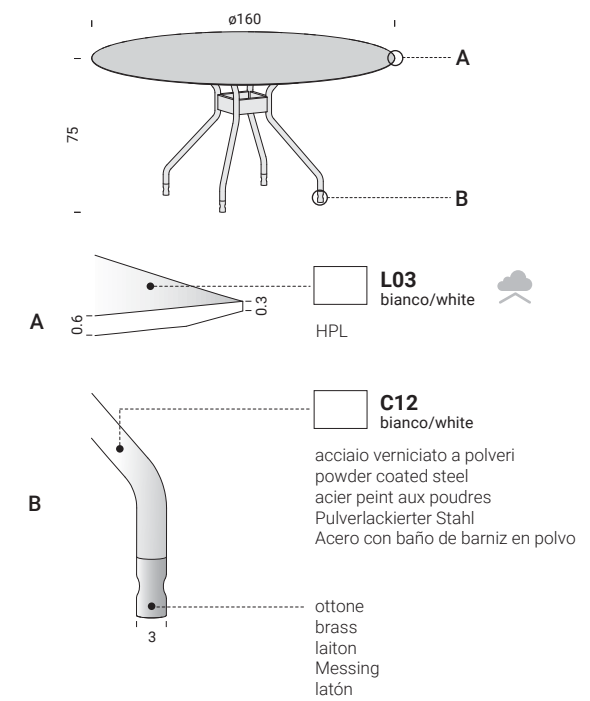

collection info
pg. 168



T8

Un progetto di Le Corbusier del 1928 ha ispirato il design di questo sistema tavoli. I nuovi materiali hanno consentito un ridisegno all'insegna della leggerezza e di una grande libertà di configurazione. E' una collezione di tavoli e panche disponibili nella versione fissa e allungabile.

A 1928 Le Corbusier project inspired the design of this table system. New materials have enabled a re-designing of this project in pursuit of lightness along with a great freedom of configuration. This is a collection of tables and benches available in both fixed and extendable versions.

Un projet de Le Corbusier de 1928 a inspiré le design de ce système de tables. Les nouveaux matériaux ont permis de le redessiner à l'enseigne de la légèreté et d'une grande liberté de configuration. C'est une collection de tables et de bancs disponibles dans la version fixe et extensible.

Ein Entwurf von Le Corbusier aus dem Jahr 1928 diente als Anregung für das Design dieses Tischsystems. Innovative Materialien prägen das aktualisierte Konzept, bei dem Leichtigkeit und eine große Gestaltungsfreiheit im Vordergrund stehen. Eine Kollektion von Tischen und Bänken, die als feste oder ausziehbare Version zur Verfügung steht.

Un diseño de Le Corbusier de 1928, inspiró el diseño de este sistema de mesas. Los nuevos materiales han permitido realizar un nuevo diseño sobre la base del antiguo, caracterizado por ligereza y gran libertad de configuración. Es una colección de mesas y banquillos disponibles en la versión fija y extensible.



disponibili riduzioni a misura / tailor-made reduction available / disponibles réductions sur mesure / Verkleinerung nach Kundenwunsch / Disponibles reducciones a medida

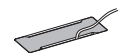

passacavo disponibile per tutti i top / cable gland available for all tops/passe-câble disponible pour tous les plateaux / Kabeldurchlass für alle Abschlussborde verfügbar / pasacables disponible para todos los sobres



iroko outdoor trattato ad olio 100% vegetale / Iroko outdoor treated with 100% vegetable oil / Iroko outdoor traité à l'huile 100% végétale / Iroko Outdoor behandelt mit 100% pflanzlichem Öl / Iroko para exteriores, tratado con aceite 100% vegetal

materiali / materials



legno massiccio
solid wood bois
massif Massivholz
madera maciza

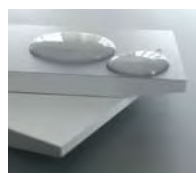

HPL



HPL+legno
HPL+wood
HPL+bois
HPL+Holz
HPL+madera



acciaio
steel
acier
Stahl
acero

Le materie prime che costituiscono il sistema T8 derivano da un processo di riutilizzo e sono a loro volta riciclabili.

The primary materials used in the system T8 are sourced from a reuse process, and are in turn recyclable.

Les matières premières qui composent le système T8 dérivent d'un processus de réutilisation et sont à leur tour recyclables.

Die Rohstoffe für das System T8 entstammen einem Wiederverwertungsprozess und sind ihrerseits wiederum recyclebar.

Las materias primas que constituyen el sistema T8 proceden de un proceso de reutilización y son, a su vez, reciclables.

finiture / finishes

top tavolo / table top / plateau de table / Tischplatte / plano de mesa

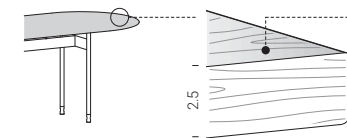

legno massiccio
solid wood
bois massif
Massivholz
madera maciza

- T01** rovere oak
- T02** noce walnut
- T03** iroko
- T04** iroko outdoor

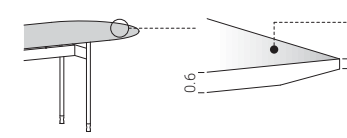

HPL
FENIX NTM®
FENIX NTM®

- L03** bianco white
- L08** grigio Londra London grey
- L06** nero black

HPL + legno/wood
bois/Holz
madera

- Y36** rovere oak
- Y34** noce walnut
- Y37** rovere affumicato smoked oak
- Y39** frassino nero black ash

HPL + ottone/brass
laiton/Messing
latón

- C31** ottone brass

eco-touch

- N01** sabbia sand

eco-touch

- N02** basalto basalt

telaio / structure / châssis / Gestell / bastidor

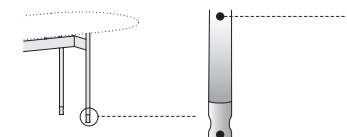

acciaio verniciato
painted steel
acier peint
lackierter Stahl
acero pintado

- C12** bianco white
- C21** seta silk
- C23** corda ecrú
- C30** ghisa cast-iron
- C14** antracite anthracite
- C08** nero black
- C18** verde green
- C26** corten corten
- C29** bronzo bronze

uso in esterno
full outdoor use

uso in esterno riparato
protected outdoor use

dimensioni / dimensions

tavoli / tables / tables / Tische / mesas

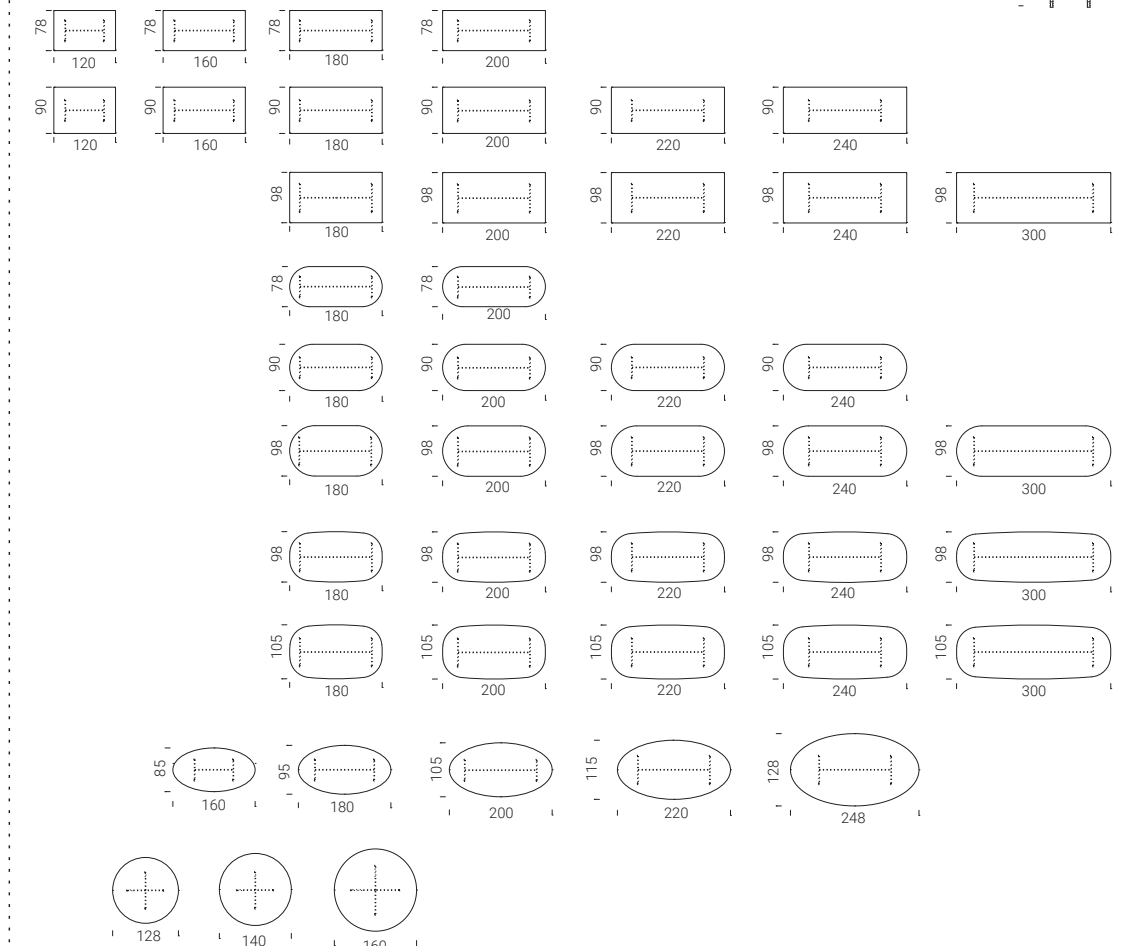

tavoli e panche allungabili / extendable tables and benches / tables et bancs extensibles / ausziehbare Tische und Bänke / mesas y banquillos extensibles

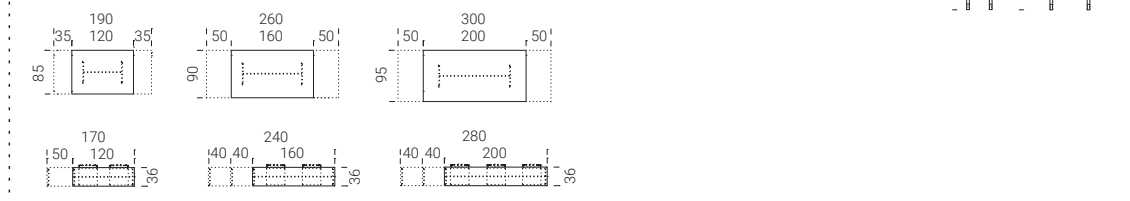

panche fisse / fixed benches / bancs fixes / Bänke / fest

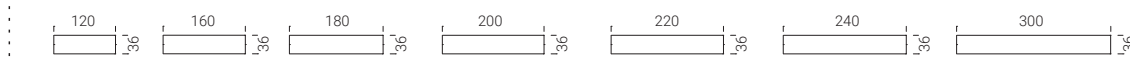

verificare a listino geometrie e finiture / check profiles and finishings in the price list / vérifier sur la liste de prix les géométries et les finitions / Siehe Preisliste für Ausführungen und Oberflächen / averiguar geometrias y acabados en la lista



T8
T801

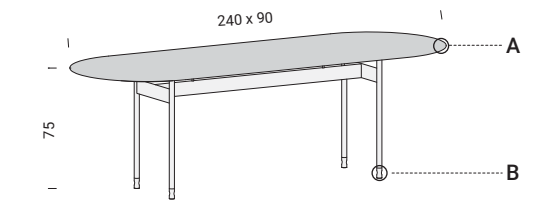

N02
basalto/basalt
HPL **eco-touch**



C30
ghisa/cast-iron
acciaio verniciato a polveri
powder coated steel
acier peint aux poudres
Pulverlackierter Stahl
Acero con baño de barniz en polvo

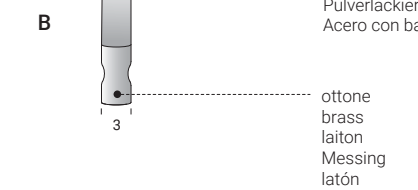

collection info
pg. 174



T8
T803

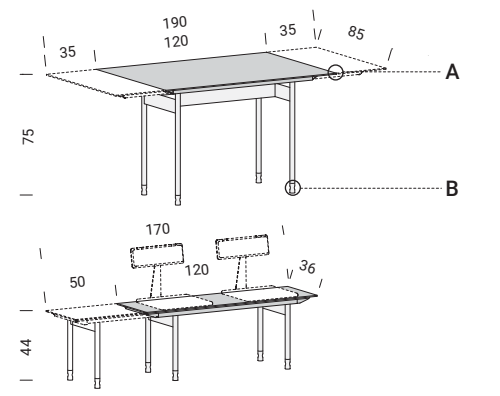

Y39
frassino nero/black ash
legno massiccio
solid wood
bois massif
Massivholz
madera maciza

C08
nero/black
acciaio verniciato a polveri
powder coated steel
acier peint aux poudres
Pulverlackierter Stahl
Acero con baño de barniz en polvo

ottone
brass
laiton
Messing
latón

collection info
pg. 174





T8
T804

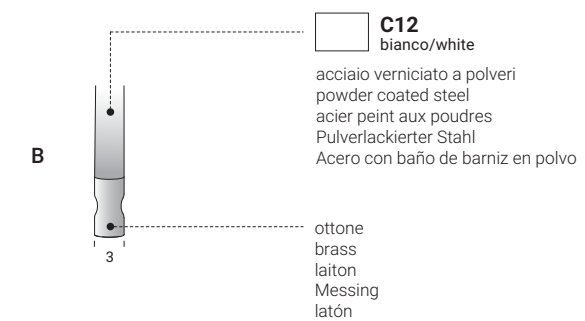
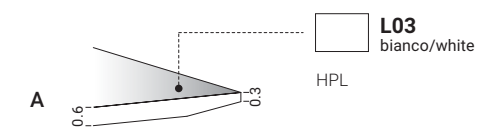
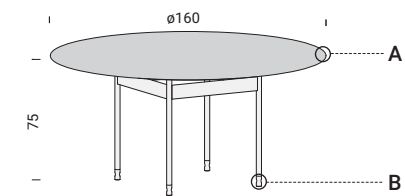

collection info
pg. 174



T8
T802

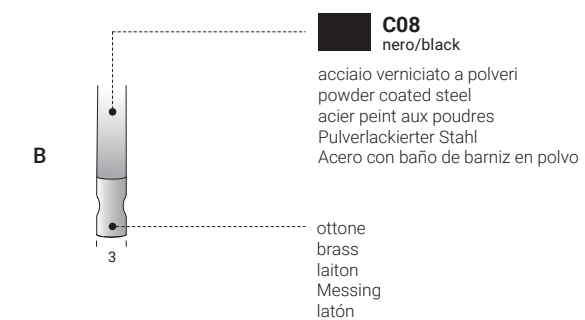
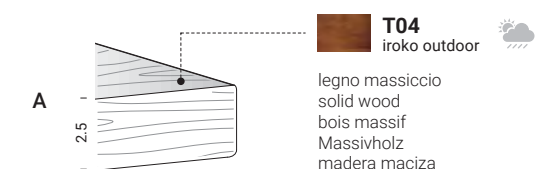
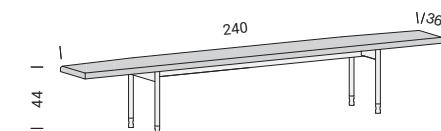
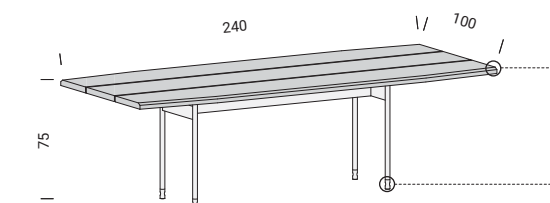

collection info
pg. 174



IPE

Una collezione progettata per costruire tavoli di grandi dimensioni, la sezione ad IPE in acciaio utilizzata per il supporto dei top tavoli conferisce grande rigidità e consente di nascondere i cavi di alimentazione di unità multimediali dal top alla parte inferiore del supporto. I top possono essere accostati per dare vita ad un sistema tavoli con dimensioni a progetto.

This is a collection that has been designed in order to create large tables, the IPE section in steel used to support the table tops provides great sturdiness and allows the power cables from multimedia devices to be concealed from the top to the bottom of the support. The table tops can be combined in order to give life to a custom-sized table system.

Une collection conçue pour construire des tables de grandes dimensions, la section en IPE d'acier utilisée pour le support des plateaux de table fournit une grande rigidité et permet de cacher les câbles d'alimentation d'unités multimédias, du plateau à la partie inférieure du support. Les plateaux peuvent être combinés pour créer un système de tables avec des dimensions selon le projet.

Bei unserer Kollektion von großflächigen, stabilen Tischen werden IPE-Stahlprofile als Stütze für die Tischplatte verwendet, denn sie gewährleisten eine ausgezeichnete Standfestigkeit und ermöglichen zudem eine versteckte Kabelführung von multimedialen Geräten auf der Platte bis zum unteren Teil des Gestells. Die Platten können aneinandergeschoben und kombiniert werden, um ein beliebig großes Tischsystem zu kreieren.

Una colección diseñada para construir mesas de gran tamaño: el perfil IPE de acero utilizado para el soporte de las encimeras de las mesas, ofrece una rigidez considerable y permite ocultar los cables de alimentación de unidades multimedia desde la encimera hasta la parte inferior del soporte. Las encimeras pueden colocarse una al lado de la otra para generar un sistema de mesas con tamaños conformes a diseño.



disponibili riduzioni a misura / custom reductions available / réductions sur mesure disponibles / Verkürzungen auf Maß erhältlich / disponibles reducciones a medida

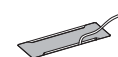

passacavo disponibile per tutti i top / cable gland available for all topspasse-câble disponible pour tous les plateaux / Kabeldurchlass für alle Abschlussborde verfügbar / pasacables disponible para todos los sobres



iroko outdoor trattato ad olio 100% vegetale / iroko outdoor treated with 100% vegetable oil / iroko outdoor traité à l'huile 100% végétale / iroko Outdoor behandelt mit 100% pflanzlichem Öl / iroko para exteriores, tratado con aceite 100% vegetal



cassetto disponibile / drawer available / tiroir disponible / Schublade verfügbar / cajón disponible



possibilità di affiancamento / possibility to place side by side / Possibilité d'association / aufstellung nebeneinander möglich / posibilidad de colocarse uno al lado del otro

materiali / materials



legno massiccio
solid wood bois
massif Massivholz
madera maciza



HPL

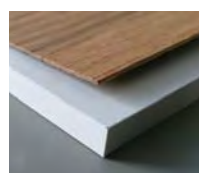

HPL+legno
HPL+wood
HPL+bois
HPL+Holz
HPL+madera



acciaio
steel
acier
Stahl
acero

Le materie prime che costituiscono il sistema IPE derivano da un processo di riutilizzo e sono a loro volta riciclabili.

The primary materials used in the system IPE are sourced from a reuse process, and are in turn recyclable.

Les matières premières qui composent le système IPE dérivent d'un processus de réutilisation et sont à leur tour recyclables.

Die Rohstoffe für das System IPE entstammen einem Wiederverwertungsprozess und sind Ihrerseits wiederum recyclebar.

Las materias primas que constituyen el sistema IPE proceden de un proceso de reutilización y son, a su vez, reciclables.

finiture / finishes

top tavolo / table top / plateaux de table / Tischplatte / plano de mesa

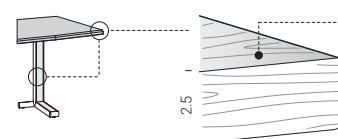

legno massiccio
solid wood
bois massif
Massivholz
madera maciza

- T01** rovere oak
- T02** noce walnut
- T03** iroko
- T04** iroko outdoor

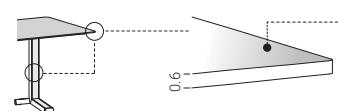

HPL
FENIX NTM
FENIX NTM

- L03** bianco white
- L08** grigio Londra London grey
- L06** nero black

HPL + legno/wood
bois/Holz
madera

- Y36** rovere oak
- Y34** noce walnut
- Y37** rovere affumicato smoked oak
- Y39** frassino nero black ash

HPL + ottone/brass
laiton/Messing
latón

- C31** ottone brass

eco-touch

- N01** sabbia sand

eco-touch

- N02** basalto basalt

telaio / structure / châssis / Gestell / bastidor

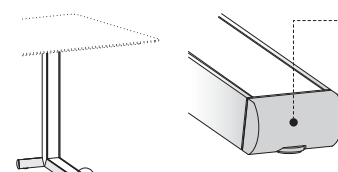

acciaio verniciato
painted steel
acier peint
lackierter Stahl
acero pintado

- C12** bianco white
- C21** seta silk
- C23** corda ecru
- C30** ghisa cast-iron
- C14** antracite anthracite
- C08** nero black
- C18** verde green
- C26** corten corten
- C29** bronzo bronze

- uso in esterno full outdoor use
- uso in esterno riparato protected outdoor use

dimensioni / dimensions

tavoli / tables / tables / Tische / mesas

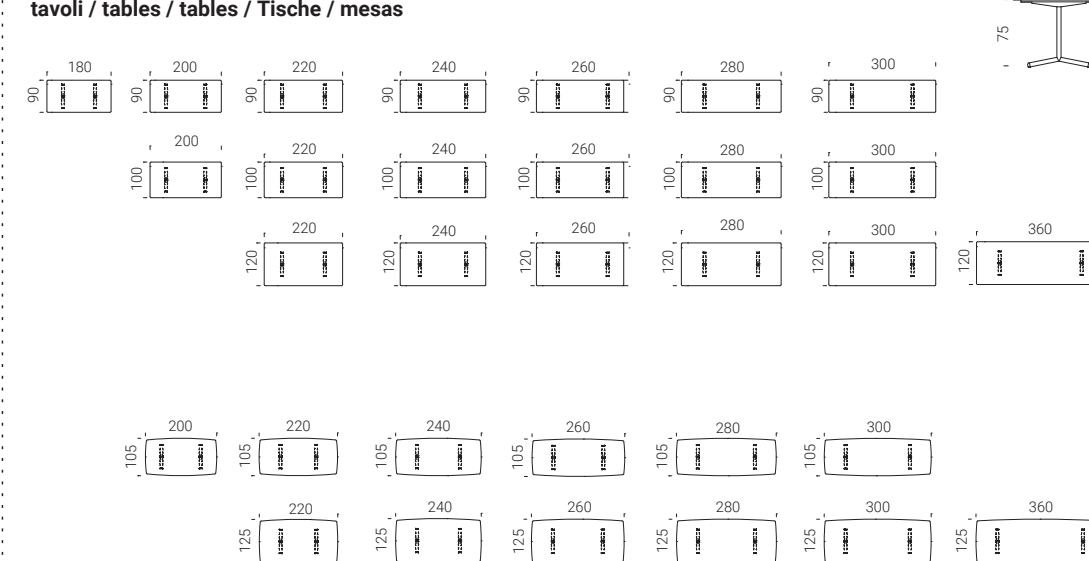

verificare a listino geometrie e finiture / check profiles and finishes in the price list / vérifier sur la liste de prix les géométries et les finitions / Siehe Preisliste für Ausführungen und Oberflächen / averiguar geometrias y acabados en la lista



IPE
IP01

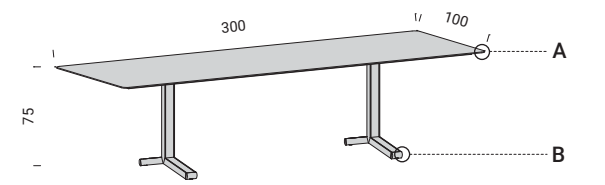

A

Y39
frassino nero/black ash

HPL impiallacciato
wood-veneered HPL
HPL plaqué bois
HPL mit Holz furnier
HPL contrachapado madera

B

C08
nero/black

acciaio verniciato a polveri
powder coated steel
acier peint aux poudres
Pulverlackierter Stahl
Acero con baño de barniz en polvo

collection info
pg. 186



IPE
IP03

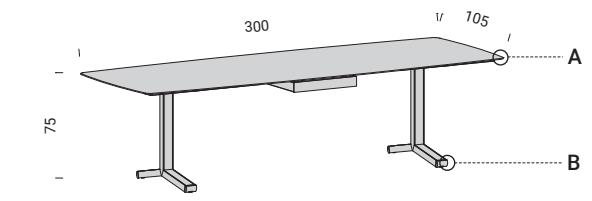

- A**
- Y36**
rovere/oak
 - HPL impiallacciato
 - wood-veneered HPL
 - HPL plaqué bois
 - HPL mit Holz furnier
 - HPL contrachapado madera
- B**
- C29**
bronzo/bronze
 - acciaio verniciato a polveri
 - powder coated steel
 - acier peint aux poudres
 - Pulverlackierter Stahl
 - Acero con baño de barniz en polvo

collection info
pg. 186



IPE
IP02

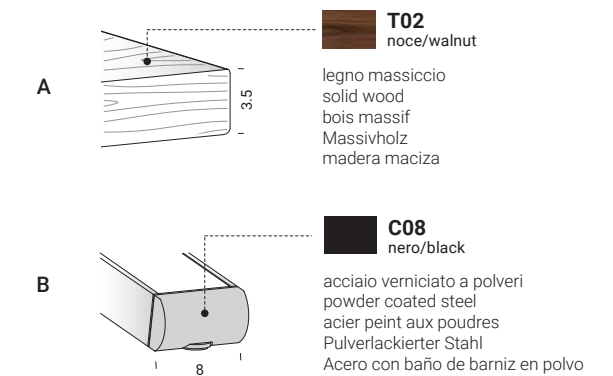
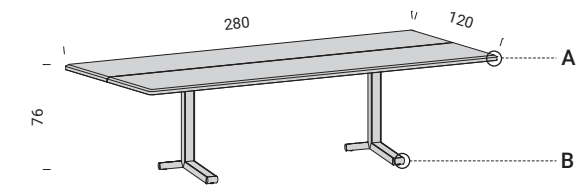

collection info
pg. 186

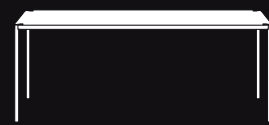

danske T

L'acciaio ed il legno massiccio si compenetrano generando una purezza volumetrica e valorizzando le essenze di rovere e noce. Come tutti i top in legno massiccio, extendo unisce le tavole grezze con la tecnica del finger joint, (tecnica che consente un' unione stabile, senza elementi estranei di connessione).

The steel and solid wood permeate to generate volumetric purity and develop the oak and walnut essences. As with all solid wood tops, Extendo joins the rough table using the finger joint technique (which allows stable joinery, without foreign couplings).

L'acier et le bois massif s'interpénètrent en générant une pureté géométrique et en valorisant les essences du chêne rouvre et du noyer. Comme tous les plateaux en bois massif, extendo unit les planches brutes avec la technique du joint par entures multiples ou finger joint, (technique qui permet une union stable, sans éléments de liaison étrangers).

Der Stahl und das Massivholz durchdringen sich gegenseitig, schaffen eine volumetrische Leichtigkeit und bringen die Eiche- und Nussbaumhölzer zur Geltung. Wie bei allen Abschlussborden aus Massivholz werden die unbearbeiteten Holztafeln mit der finger-joint-Methode ohne Verbindungselemente stabil zusammengesetzt.

El acero y la madera maciza se compenetran generando una pureza volumétrica, destacando las maderas de roble y nogal. Como todos los sobres de madera maciza, extendo une las tablas sin tratar con la técnica del "finger joint" (técnica que permite una "unión estable, sin elementos extraños de conexión).

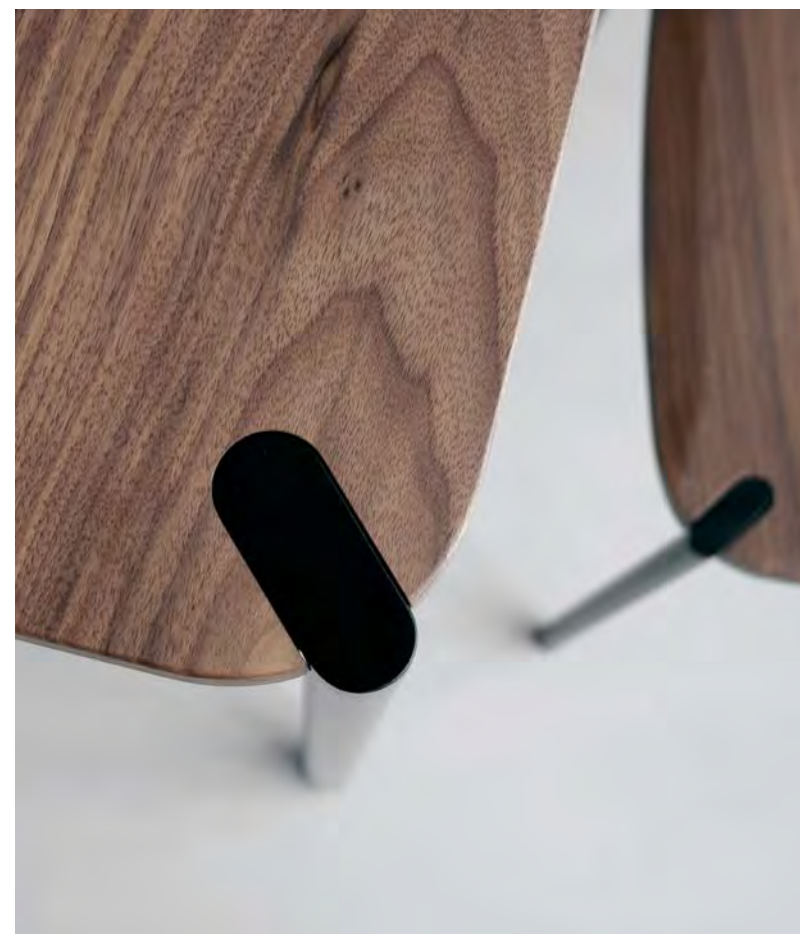

disponibili riduzioni a misura / tailor-made reduction available / disponibles réductions sur mesure / Verkleinerung nach Kundenwunsch / Disponibles reducciones a medida

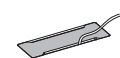

passacavo disponibile per tutti i top / cable gland available for all tops / passe-câble disponible pour tous les plateaux / Kabeldurchlass für alle Abschlussborde verfügbar / pasacables disponible para todos los sobres

materiali / materials



legno massiccio
solid wood
bois massif
Massivholz
madera maciza



acciaio
steel
acier
Stahl
acero

Le materie prime che costituiscono il sistema danske T derivano da un processo di riutilizzo e sono a loro volta riciclabili.

The primary materials used in the system danske T are sourced from a reuse process, and are in turn recyclable.

Les matières premières qui composent le système danske T dérivent d'un processus de réutilisation et sont à leur tour recyclables.

Die Rohstoffe für das System danske T entstammen einem Wiederverwertungsprozess und sind Ihrerseits wiederum recyclebar.

Las materias primas que constituyen el sistema danske T proceden de un proceso de reutilización y son, a su vez, reciclables.

finiture / finishes

top tavolo / table top / plateaux de table / Tischplatte / plano de mesa

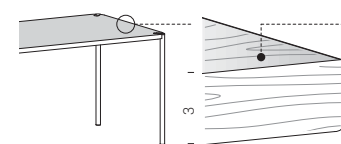

legno massiccio
solid wood
bois massif
Massivholz
madera maciza

T01 rovere
oak
T02 noce
walnut
T03 iroko

telaio / structure / châssis / Gestell / bastidor

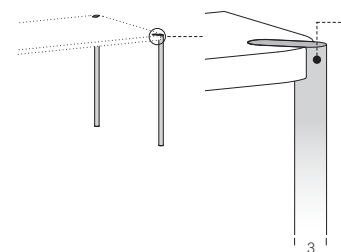

acciaio verniciato
painted steel
acier peint
lackierter Stahl
acero pintado

C12 bianco
white
C21 seta
silk
C23 corda
ecru
C30 ghisa
cast-iron
C14 antracite
anthracite
C08 nero
black
C18 verde
green
C26 corten
corten
C29 bronzo
bronze

dimensioni / dimensions

tavoli / tables / tables / Tische / mesas

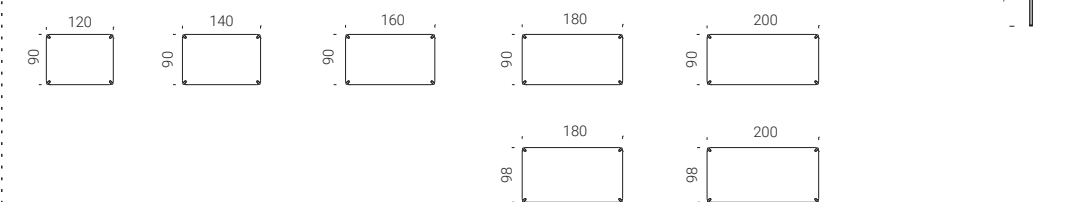

scrivani / writing desks / secrétaires / Schreibtischen / escritorios

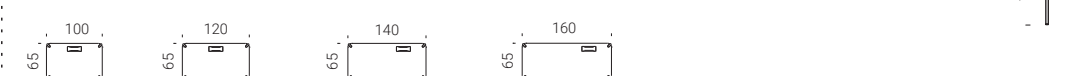

scrivani a parete / wall-mounted writing desks / bureaux au mur / Wandschreibtische
escritorios de pared



consolle a parete / wall-mounted console table / consoles murales / Wandkonsolen
consola de pared

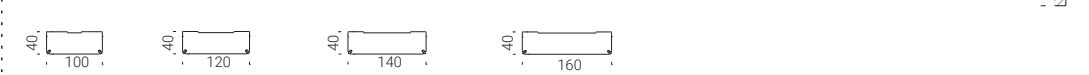

verificare a listino geometrie e finiture / check profiles and finishings in the price list / vérifier sur la liste de prix les géométries et les finitions / Siehe Preisliste für Ausführungen und Oberflächen / averiguar geometrías y acabados en la lista



danske T
DT01

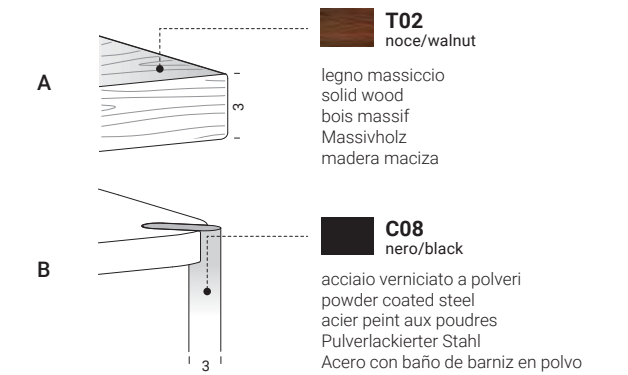
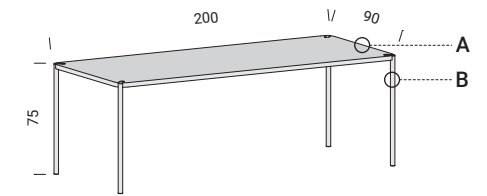

collection info
pg. 194

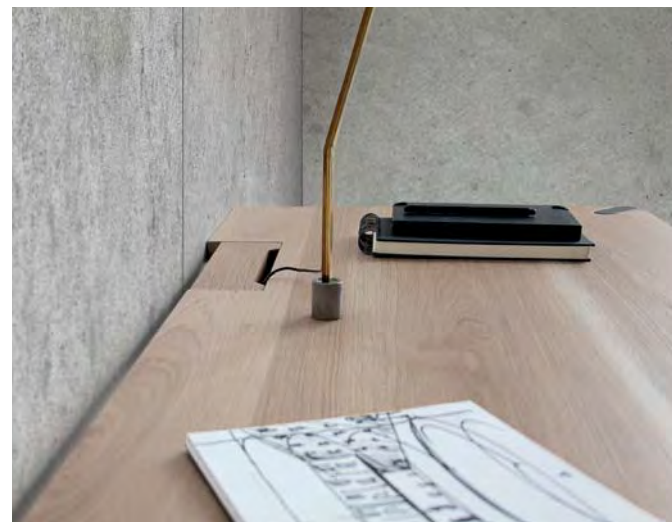

danske T
DT02

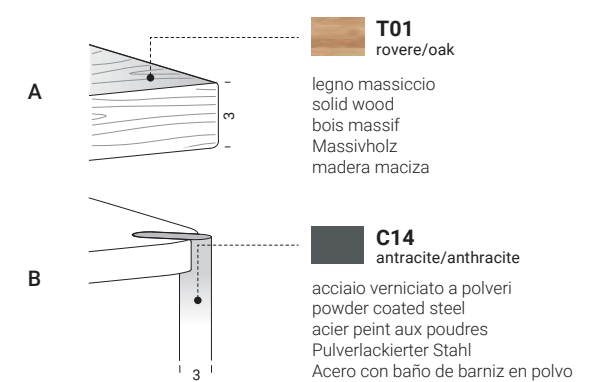
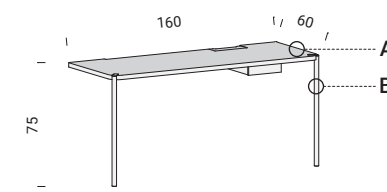

collection info
pg. 194



hammer

Progettato senza compromessi per un impiego outdoor, è comunque disponibile nelle finiture noce e rovere massiccio per l'inserimento indoor. Per la versione outdoor il top e le sedute sono in Iroko trattato con olio naturale, il telaio è in acciaio corten, o acciaio verniciato a polveri, gli elementi di connessione sono in acciaio inox e ottone.

Designed without compromise for outdoor use, it is available in solid walnut and oak finishes for indoor use. For the outdoor version, the top and the chairs are in Iroko treated with natural oil, the frame is in Corten steel or powder painted steel. The joinery elements are in stainless steel or brass.

Conçu sans compromis pour une utilisation en extérieur, il est toutefois disponible dans les finitions noyer et chêne rouvre massif pour l'insertion d'intérieur. Pour la version d'extérieur, le plateau et les assises sont en Iroko traité avec de l'huile naturelle, la structure est en acier Corten, ou en acier verni par poudres, les éléments de connexion sont en acier inox et laiton.

Kompromissloser Entwurf für den Outdoor-Einsatz, steht jedoch auch als Indoor-Lösung mit Endbehandlung Nussbaum und Massiveiche zur Verfügung. Für die Outdoor-Version sind Abschlussbord und Sitze aus mit natürlichem Öl behandeltem Iroko, der Rahmen ist aus Corten-Stahl oder pulverlackiertem Stahl und die Verbindungsstücke sind aus Edelstahl und Messing.

Diseñada para usarla sin problemas en el exterior, también está disponible en los acabados nogal y roble macizo para su uso en el interior. Para la versión de exterior el sobre y los asientos son de iroko tratado con aceite natural, el bastidor es de acero corten, o acero tratado con barniz en polvo, los elementos de unión son de acero inoxidable y latón.



disponibili riduzioni a misura / custom reductions available / réductions sur mesure disponibles / Verkürzungen auf Maß erhältlich / disponibles reducciones a medida



iroko outdoor trattato ad olio 100% vegetale / iroko outdoor treated with 100% vegetable oil / iroko outdoor traité à l'huile 100% végétale / iroko Outdoor behandelt mit 100% pflanzlichem Öl / iroko para exteriores, tratado con aceite 100% vegetal

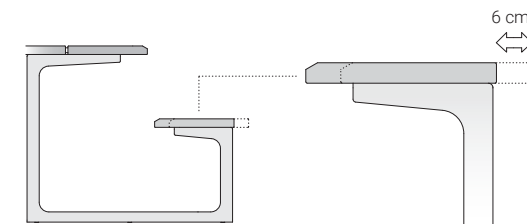

materiali / materials



legno massiccio
solid wood bois
massif Massivholz
madera maciza

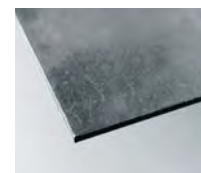

acciaio
steel
acier
Stahl
acero

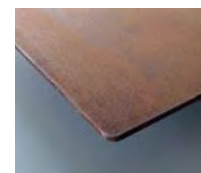

corten

Le materie prime che costituiscono il sistema hammer derivano da un processo di riutilizzo e sono a loro volta riciclabili.

The primary materials used in the system hammer are sourced from a reuse process, and are in turn recyclable.

Les matières premières qui composent le système hammer dérivent d'un processus de réutilisation et sont à leur tour recyclables.

Die Rohstoffe für das System hammer entstammen einem Wiederverwertungsprozess und sind Ihrerseits wiederum recyclebar.

Las materias primas que constituyen el sistema hammer proceden de un proceso de reutilización y son, a su vez, reciclables.

finiture / finishes

top tavolo / table top / plateau de table / Tischplatte / plano de mesa

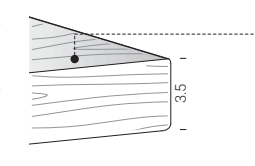
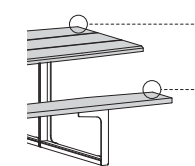

legno massiccio
solid wood
bois massif
Massivholz
madera maciza

- T01** rovere oak
- T02** noce walnut
- T03** iroko
- T04** iroko outdoor

telaio / structure / châssis / Gestell / bastidor

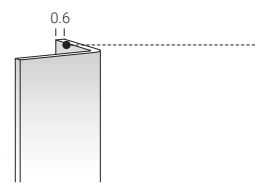
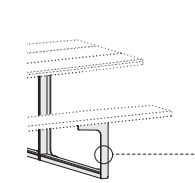

acciaio verniciato
painted steel
acier peint
lackierter Stahl
acero pintado

- C12** bianco white
- C21** seta silk
- C23** corda ecrú
- C30** ghisa cast-iron
- C14** antracite anthracite
- C08** nero black
- C18** verde green
- C26** corten corten
- C29** bronzo bronze
- C27** corten outdoor corten outdoor

uso in esterno
full outdoor use

dimensioni / dimensions

tavoli / tables / tables / Tische / mesas

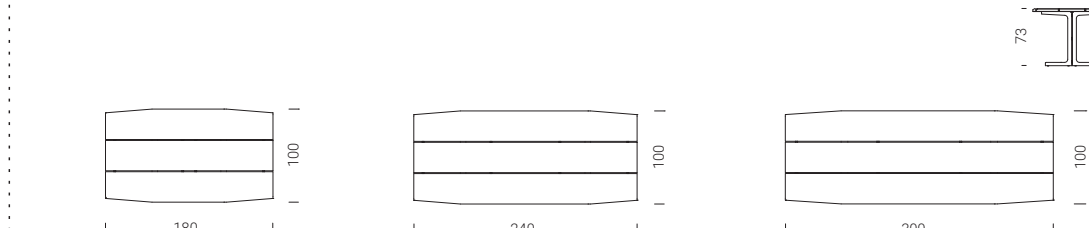
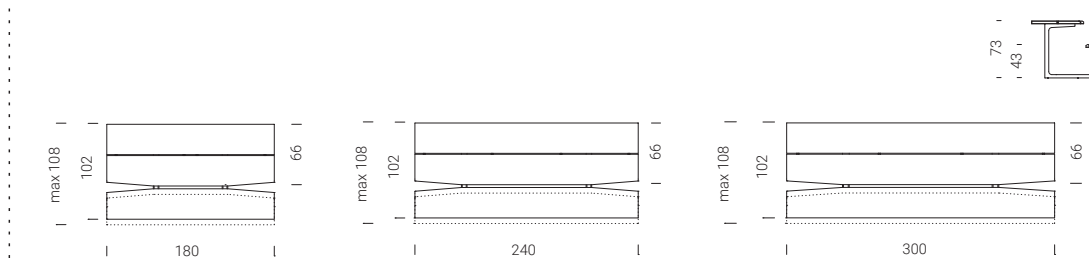
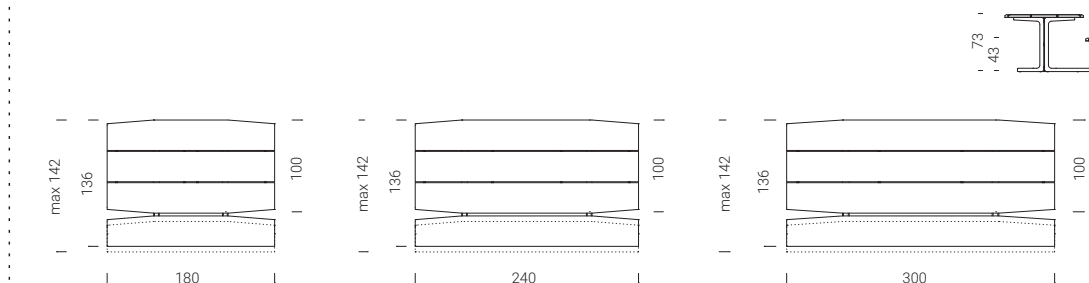
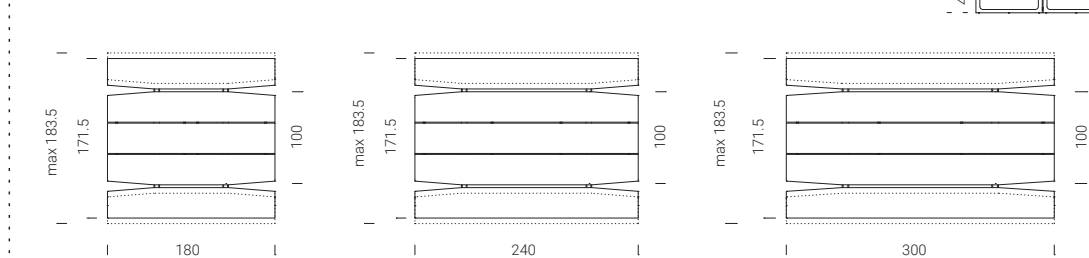

verificare a listino geometrie e finiture / check profiles and finishings in the price list / vérifier sur la liste de prix les géométries et les finitions / Siehe Preisliste für Ausführungen und Oberflächen / averiguar geometrias y acabados en la lista

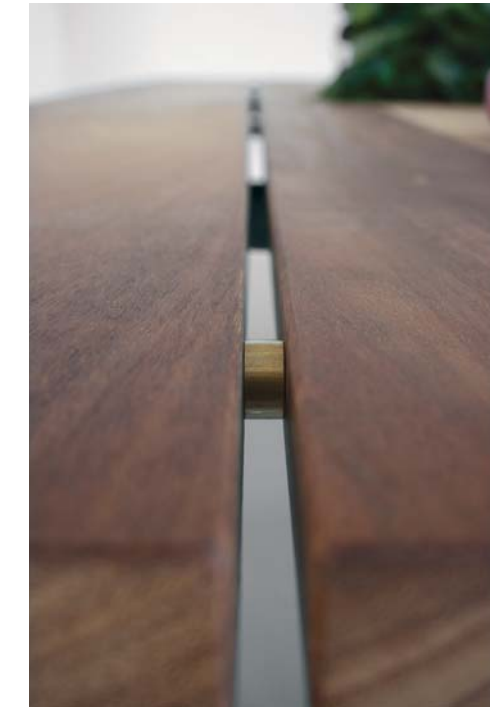
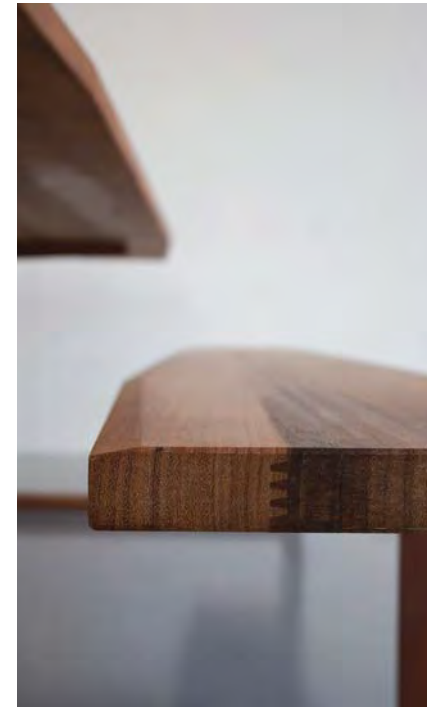

hammer
HA04

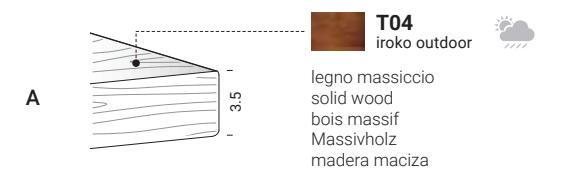
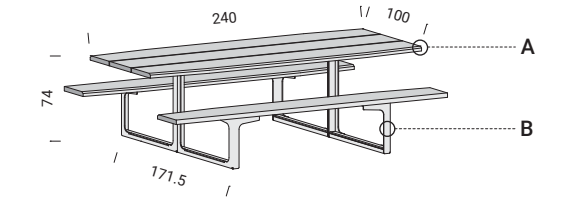

collection info
pg. 200



hammer

HA05

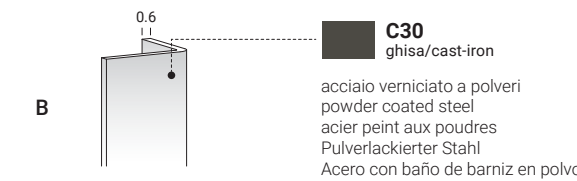
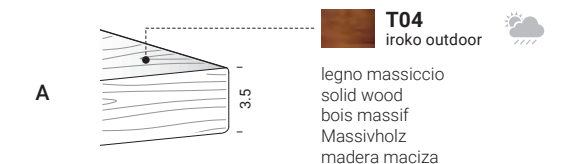
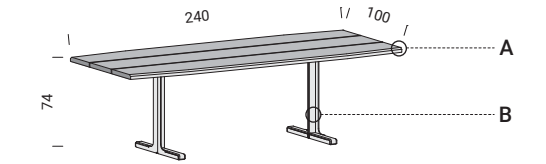

T04
iroko outdoor

legno massiccio
solid wood
bois massif
Massivholz
madera maciza

C30
ghisa/cast-iron

acciaio verniciato a polveri
powder coated steel
acier peint aux poudres
Pulverlackierter Stahl
Acero con baño de barniz en polvo

collection info
pg. 200



hammer

HA06

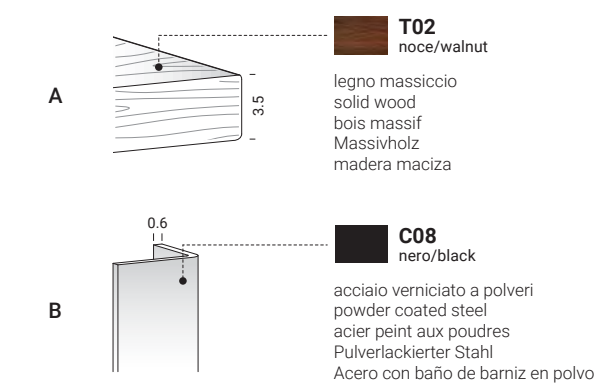
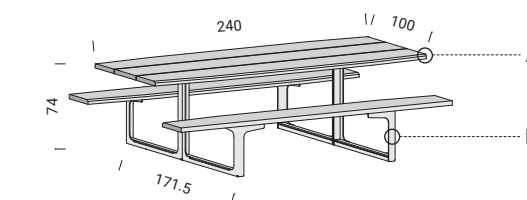

collection info
pg. 200



hammer
HA03

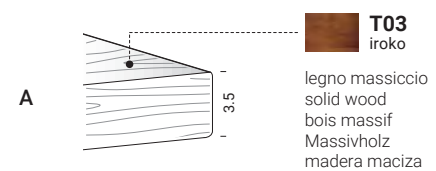
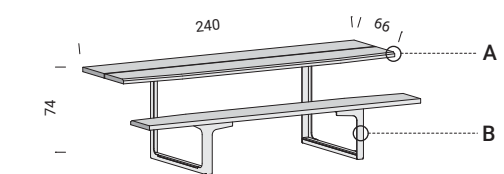

T03
iroko
legno massiccio
solid wood
bois massif
Massivholz
madera maciza

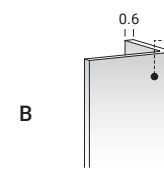

C26
corten
acciaio verniciato a polveri
powder coated steel
acier peint aux poudres
Pulverlackierter Stahl
Acero con baño de barniz en polvo

collection info
pg. 200



hammer
HA02

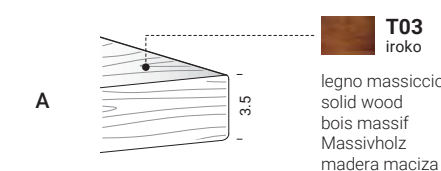
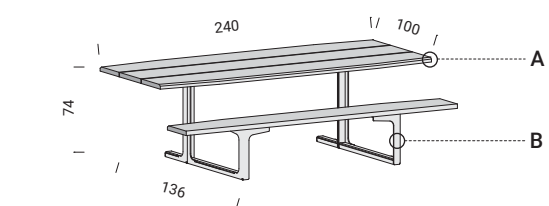

T03
iroko
legno massiccio
solid wood
bois massif
Massivholz
madera maciza

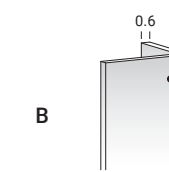

C26
corten
acciaio verniciato a polveri
powder coated steel
acier peint aux poudres
Pulverlackierter Stahl
Acero con baño de barniz en polvo

collection info
pg. 200



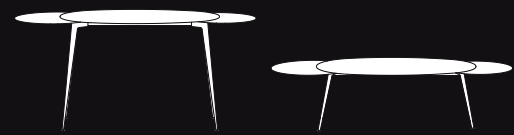

mr.hyde

mr.hyde è una collezione di tavoli che nascondono nella parte sottostante uno o più dischi con diametro 48-54 cm. I dischi possono essere estratti ruotandoli, aumentando la superficie disponibile del tavolino. I top mr.hyde ed i dischi estraibili sono in hpl spessore 6 mm che nello sviluppo del perimetro viene ridotto tramite fresatura ad uno spessore di soli 3 mm.

mr.hyde is a collection of tables with one or more hidden discs of diameters between 48 and 54 cm. The discs can be extracted by turning them, thus increasing the available space on the table. The mr.hyde tops and extractable discs are in 6 mm HPL, milled around the edge to a thickness of just 3 mm.

mr.hyde est une collection de tables de café qui cachent dans la partie sous-jacente un ou plusieurs disques avec un diamètre de 48-54 cm. Les disques peuvent être extraits en les faisant tourner, en augmentant ainsi la superficie disponible de la table basse. Les plateaux mr.hyde et les disques extractibles sont réalisés en HPL de 6 mm d'épaisseur, qui est réduite par fraisage le long du périmètre à une épaisseur de seulement 3 mm.

mr.hyde ist eine Kollektion von Tables, die auf der Unterseite eine oder mehrere runde Platten mit einem Durchmesser von 48-54 cm verbergen. Die runden Platten können herausgedreht werden und vergrößern so die Ablagefläche des Tisches. Die HPL-Tischplatte und die runden Platten sind aus 6 mm starkem HPL gefertigt, der Rand ist dagegen auf eine Stärke von 3 mm.

mr.hyde es una colección de tables que esconden en la parte inferior uno o varios discos, con un diámetro de 48-54 cm. Los discos pueden extraerse girándolos, aumentando la superficie disponible de la mesita. Los sobres de mr.hyde y los discos extraíbles son de hpl, de 6 mm de espesor, que en el desarrollo del perímetro se reduce a través de fresado a un espesor solo de 3 mm.



materiali / materials

HPL+legno
HPL+wood
HPL+bois
HPL+Holz
HPL+madera

HPL

acciaio
steel
acier
Stahl
acero

Le materie prime che costituiscono il sistema mr.hyde derivano da un processo di riutilizzo e sono a loro volta riciclabili.

The primary materials used in the system mr.hyde are sourced from a reuse process, and are in turn recyclable.

Les matières premières qui composent le système mr.hyde dérivent d'un processus de réutilisation et sont à leur tour recyclables.

Die Rohstoffe für das System mr.hyde entstammen einem Wiederverwertungsprozess und sind Ihrerseits wiederum recyclebar.

Las materias primas que constituyen el sistema mr.hyde proceden de un proceso de reutilización y son, a su vez, reciclables.

finiture / finishes

top tavolo / table top / plateau de table / Tischplatte / plano de mesa

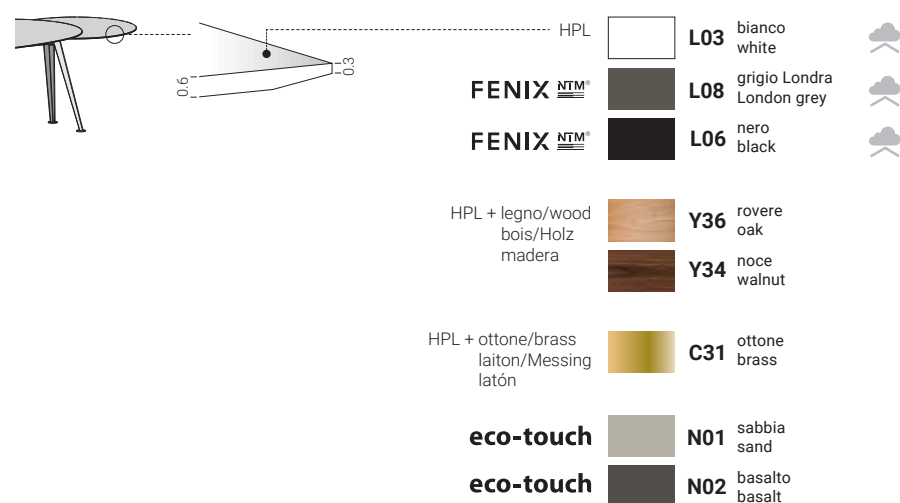

telaio / structure / châssis / Gestell / bastidor

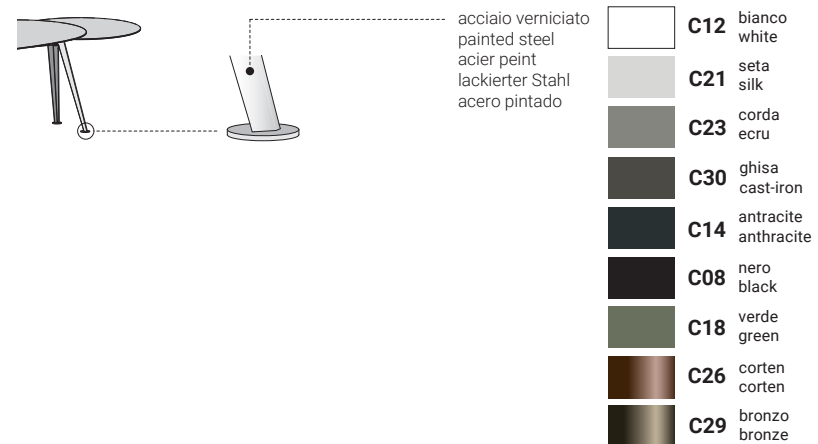

uso in esterno riparato protected outdoor use

dimensioni / dimensions

tavoli / tables / tables / Tische / mesas

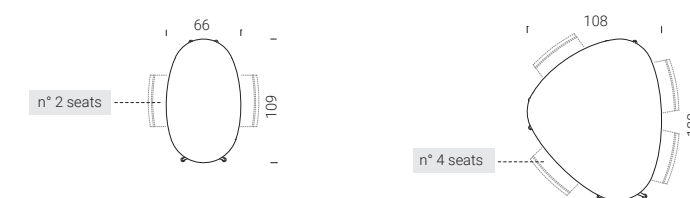

tavoli ampliabili / extension tables / tables à rallonges / Erweiterbare Tische / mesas ampliables

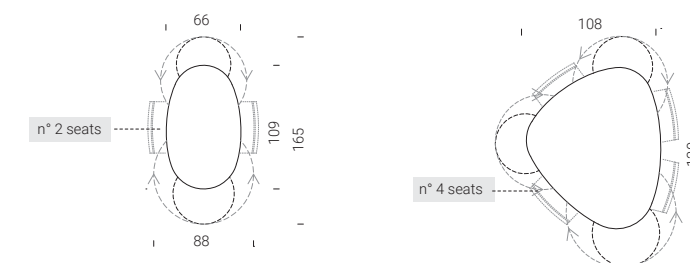

tavoli bassi / coffee tables / tables basses / Couchtische / mesas bajas

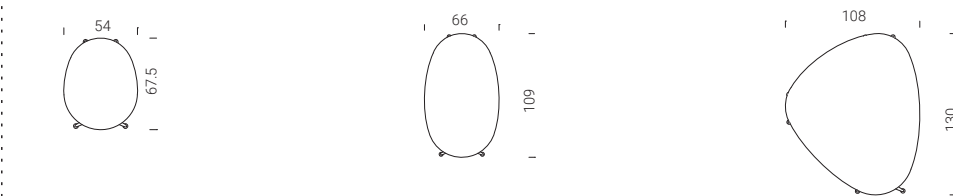

tavoli bassi ampliabili / extension coffee tables / tables basses à rallonges Erweiterbare Couchtische / mesas bajas ampliables

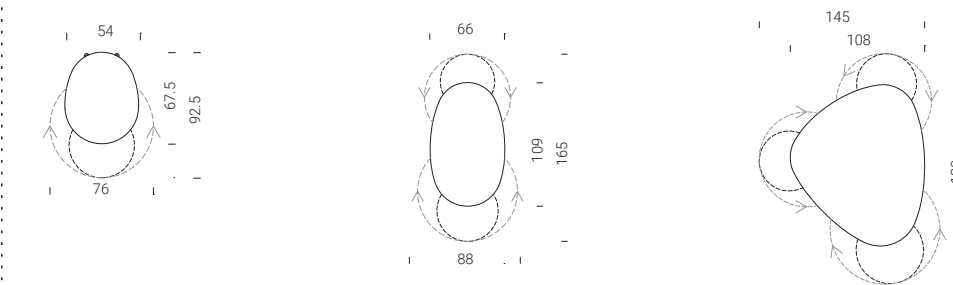

verificare a listino geometrie e finiture / check profiles and finishings in the price list / vérifier sur la liste de prix les géométries et les finitions / Siehe Preisliste für Ausführungen und Oberflächen / averiguar geometrias y acabados en la lista

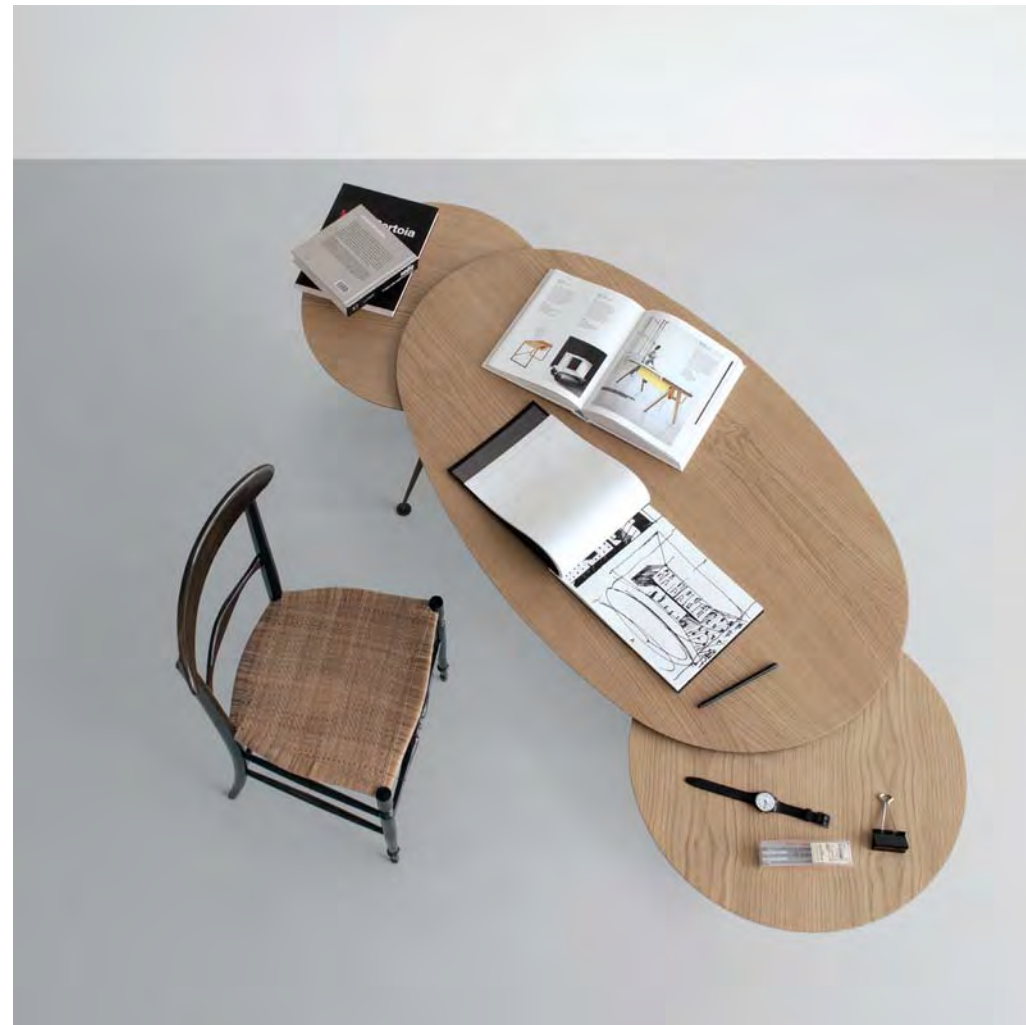

mr.hyde
MH28

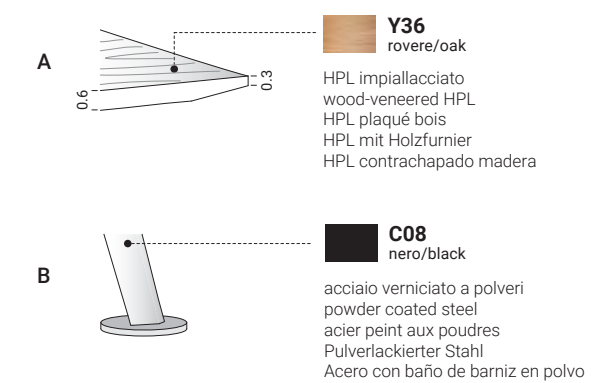
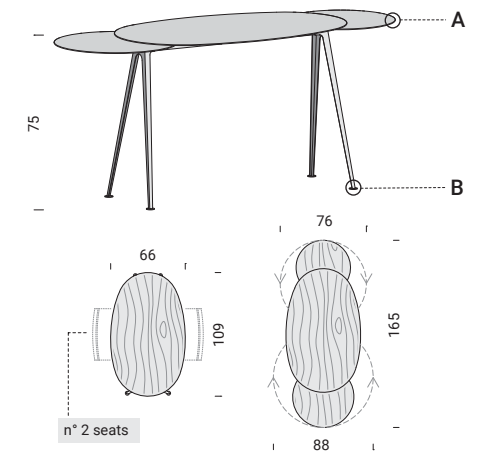

collection info
pg. 210



mr.hyde
MH29

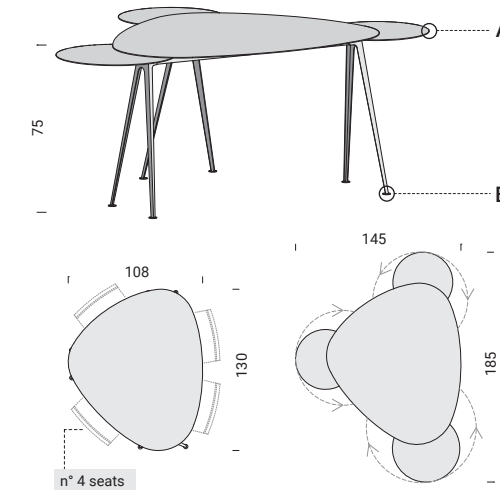

- A**
- N01** sabbia/sand
 - HPL **eco-touch**
- B**
- C12** bianco/white
 - acciaio verniciato a polveri
powder coated steel
acier peint aux poudres
Pulverlackierter Stahl
Acero con baño de barniz en polvo

collection info
pg. 210



mr.hyde
MH01

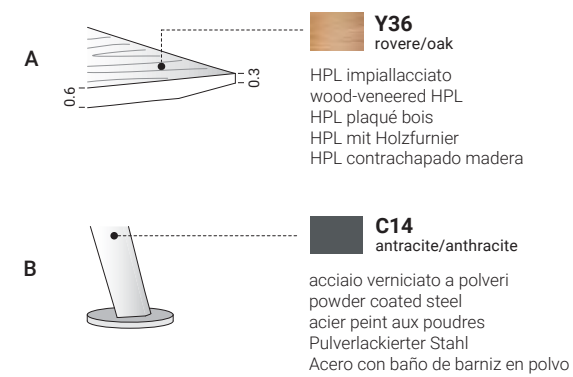
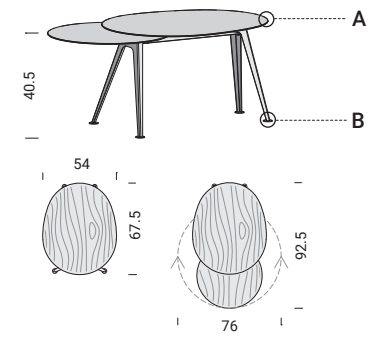

collection info
pg. 210



mr.hyde
MH07

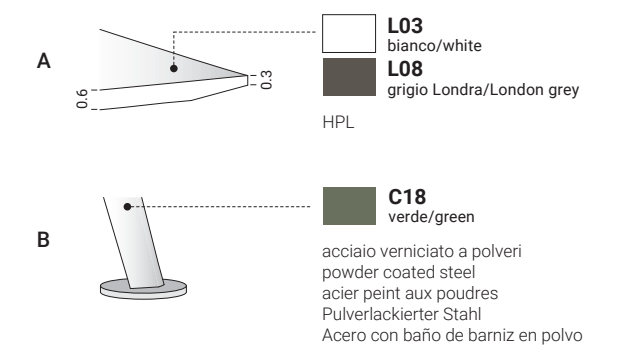
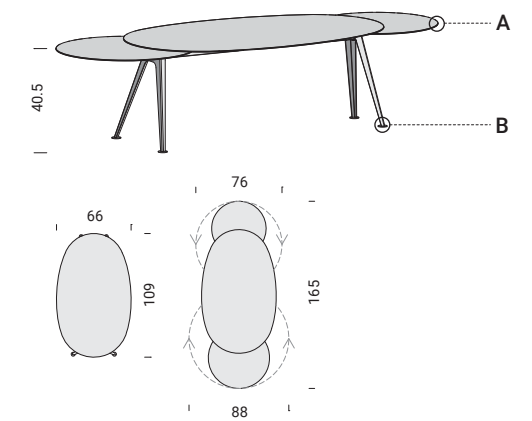

collection info
pg. 210



mr.hyde
MH02

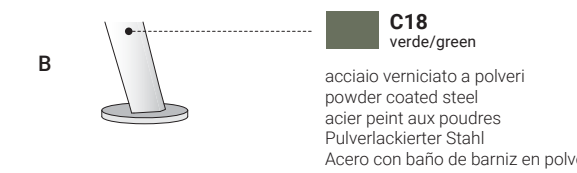
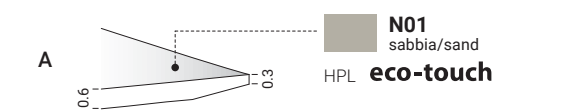
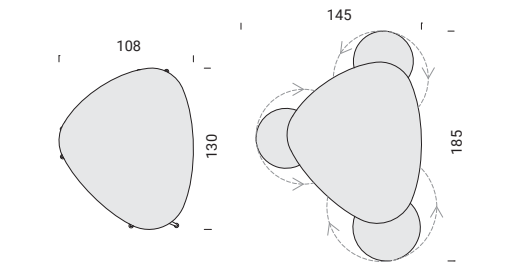
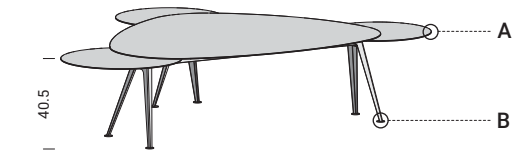

collection info
pg. 210



déco

Una collezione di tavolini che si ispira ad uno stile che ha influenzato l'architettura ed il design negli anni 30. Le nuove tecnologie per la lavorazione dei metalli e le alte performance dei materiali impiegati, hanno consentito di reinterpretare uno stile dalle forme classiche in geometrie contemporanee.

This is a collection of coffee tables inspired by a style that influenced both the fields of architecture and design during the 1930s. The new metalworking technologies and the high-performing materials used, have made it possible to re-interpret a style with classical forms in contemporary profiles.

Une collection de tables basses qui s'inspire d'un style qui a influencé l'architecture et le design dans les années 30. Les nouvelles technologies pour l'usinage des métaux et les performances élevées des matériaux employés ont permis de réinterpréter un style aux formes classiques en géométries contemporaines.

Eine Kollektion von Tischen, die sich am Art Déco inspiriert, einer Stilrichtung, die die Architektur und das Design der 1930er Jahre beeinflusst hat. Innovative Technologien bei der Metallbearbeitung und leistungsfähige Materialien erlauben die Neuinterpretation eines von klassischen Formen geprägten Stils, die mit zeitgenössischen Konturen überzeugt.

Una colección de mesitas inspirada en el estilo que predominó en la arquitectura y el diseño de los años 30. Las nuevas tecnologías para el procesamiento de metales y las altas prestaciones de los materiales utilizados, permitieron reinterpretar un estilo caracterizado por formas clásicas, creando geometrías contemporáneas.



materiali / materials



HPL+legno
HPL+wood
HPL+bois
HPL+Holz
HPL+madera



HPL



acciaio
steel
acier
Stahl
acero

Le materie prime che costituiscono il sistema déco derivano da un processo di riutilizzo e sono a loro volta riciclabili.

The primary materials used in the system déco are sourced from a reuse process, and are in turn recyclable.

Les matières premières qui composent le système déco dérivent d'un processus de réutilisation et sont à leur tour recyclables.

Die Rohstoffe für das System déco entstammen einem Wiederverwertungsprozess und sind Ihrerseits wiederum recyclebar.

Las materias primas que constituyen el sistema déco proceden de un proceso de reutilización y son, a su vez, reciclables.

finiture / finishes

top tavolo / table top / plateaux de table / Tischplatte / plano de mesa

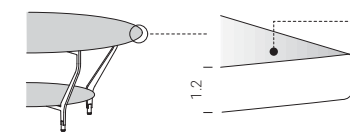

marmo
marble
marbre
Marmor
mármol

Z01 bianco Carrara
white Carrara
Z02 nero Marquiña
black Marquiña

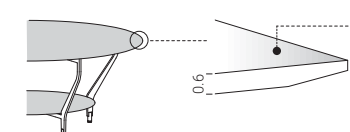

HPL
FENIX NTM®
FENIX NTM®

L03 bianco
white
L08 grigio Londra
London grey
L06 nero
black

HPL + legno/wood
bois/Holz
madera
Y36 rovere
oak
Y34 noce
walnut
Y37 rovere affumicato
smoked oak
Y39 frassino nero
black ash

HPL + ottone/brass
laiton/Messing
latón
C31 ottone
brass

eco-touch **N01** sabbia
sand

eco-touch **N02** basalto
basalt

telaio / structure / châssis / Gestell / bastidor

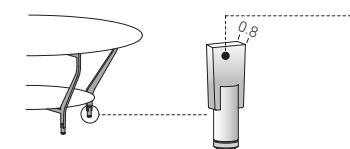

acciaio verniciato
painted steel
acier peint
lackierter Stahl
acero pintado

C12 bianco
white
C21 seta
silk
C23 corda
ecru
C30 ghisa
cast-iron
C14 antracite
anthracite
C08 nero
black
C18 verde
green
C26 corten
corten
C29 bronzo
bronze

uso in esterno riparato
protected outdoor use

dimensioni / dimensions

tavoli bassi / coffee tables / tables basses / Couchtische / mesas bajas

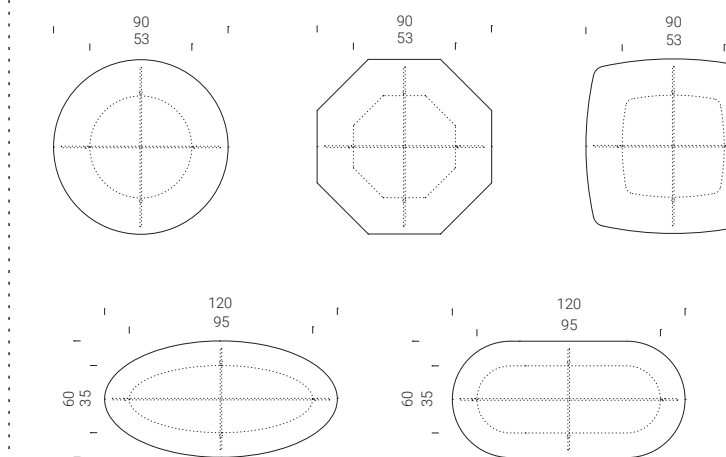

tavoli bassi / coffee tables / tables basses / Couchtische / mesas bajas

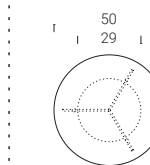

verificare a listino geometrie e finiture / check profiles and finishings in the price list / vérifier sur la liste de prix les géométries et les finitions / Siehe Preisliste für Ausführungen und Oberflächen / averiguar geometrías y acabados en la lista



déco
DE03

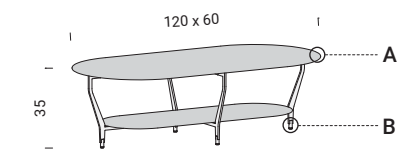

- A**
- Y37**
rovere affumicato/smoked oak
- HPL impiallacciato
wood-veneered HPL
HPL plaqué bois
HPL mit Holz furnier
HPL contrachapado madera
- B**
- C29**
bronzo/bronze
- acciaio verniciato a polveri
powder coated steel
acier peint aux poudres
Pulverlackierter Stahl
Acero con baño de barniz en polvo

collection info
pg. 220



déco
DE06

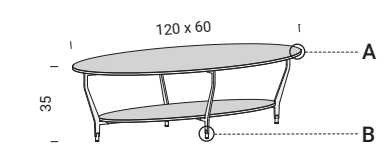

- A**
- Z02**
nero Marquiña/black Marquiña
- marmo
marble
marbre
Marmor
mármol
- B**
- C08**
nero/black
- acciaio verniciato a polveri
powder coated steel
acier peint aux poudres
Pulverlackierter Stahl
Acero con baño de barniz en polvo

collection info
pg. 220



déco

DE01

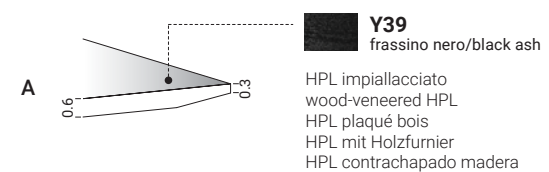
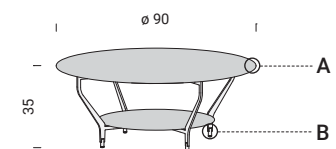

collection info
pg. 220



déco

DE05

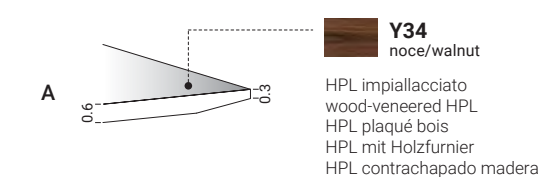
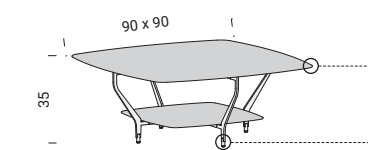

collection info
pg. 220



déco

DE02

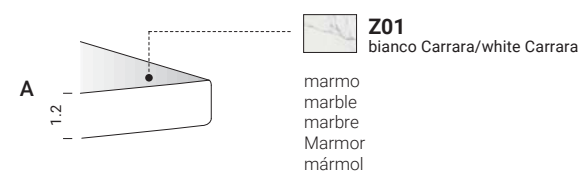
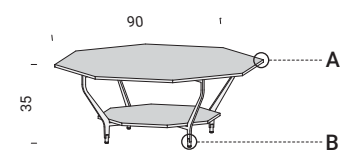

Z01
bianco Carrara/white Carrara

marmo
marble
marbre
Marmor
mármol

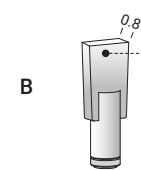

C12
bianco/white

acciaio verniciato a polveri
powder coated steel
acier peint aux poudres
Pulverlackierter Stahl
Acero con baño de barniz en polvo

collection info
pg. 220



déco

DE04

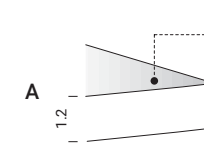
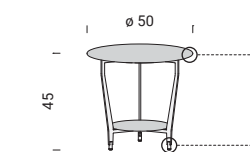

Z02
nero Marquiña/black Marquiña

marmo
marble
marbre
Marmor
mármol

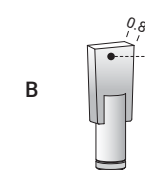

C14
antracite/anthracite

acciaio verniciato a polveri
powder coated steel
acier peint aux poudres
Pulverlackierter Stahl
Acero con baño de barniz en polvo

collection info
pg. 220

seating



viking K
pg. 232



viking W
pg. 236



viking L
pg. 238

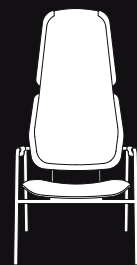

viking GL
pg. 240



danske C1
pg. 246



danske C2
pg. 248



danske C3
pg. 252





viking

La lama in acciaio che ricorda il profilo di chiglia delle navi vichinghe è la spina dorsale di tutte le sedute che fanno parte della collezione. Su di essa si innestano il fondello lo schienale e gli appoggi a terra. Il telaio è in acciaio, mentre i componenti di seduta e schienale sono disponibili in multistrato o cuoio.

The steel blade recalling the contour of the keel of Viking ships is the backbone of all the chairs belonging to this collection. The chair seat, the backrest and the chair legs are inserted onto this. The chair frame is made of steel, while the seat and backrest are available in either plywood or leather.

La lame en acier qui rappelle le profil de la quille des navires vikings est l'épine dorsale de toutes les assises qui font partie de la collection. C'est sur elle que s'enclenchent le fond, le dossier et les appuis au sol. Le châssis est en acier alors que les composants de l'assise et du dossier sont disponibles en multicouche ou en cuir.

Ein Stahlprofil, das an den Rumpf der Wikingerschiffe erinnert, stellt das Rückgrat aller Stühle dieser Kollektion dar, an dem die Sitzfläche, die Rückenlehne und die Bodenstützen befestigt sind. Der Rahmen ist aus Stahl gefertigt, während die Sitzflächen und die Lehnen in Sperrholz oder Leder erhältlich sind.

La cuchilla de acero que recuerda el perfil de la quilla de los barcos vikingos, es la espina dorsal de todos los asientos que forman parte de la colección. Sobre ella, se ensamblan el fondo, el respaldo y los apoyos en el suelo. El bastidor es de acero, mientras que los componentes del asiento y el respaldo, están disponibles en madera estratificada o cuero.



materiali / materials



cuoio
cow-hide
cuir
Kernleder
cuero



multistrato
plywood
contre-plaqué
Sperrholz
contrachapado



acciaio
steel
acier
Stahl
acero

Le materie prime che costituiscono il sistema viking derivano da un processo di riutilizzo e sono a loro volta riciclabili.

The primary materials used in the system viking are sourced from a reuse process, and are in turn recyclable.

Les matières premières qui composent le système viking dérivent d'un processus de réutilisation et sont à leur tour recyclables.

Die Rohstoffe für das System viking entstammen einem Wiederverwertungsprozess und sind Ihrerseits wiederum recyclebar.

Las materias primas que constituyen el sistema viking proceden de un proceso de reutilización y son, a su vez, reciclables.

finiture / finishes

fondello e schienale / seat and back / assise et dossier / Sitzfläche und Rückenlehne / asiento y respaldo

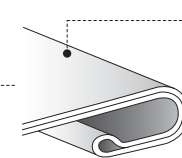

cuoio
cow-hide
cuir
Kernleder
cuero

F01 tabacco
tobacco

F03 corteccia
bark

F02 nero
black

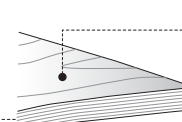
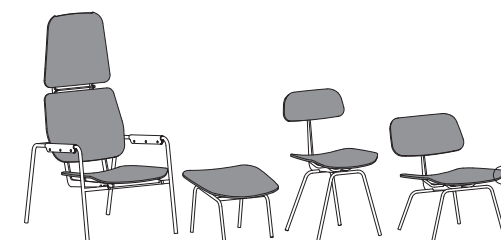

multistrato
plywood
contre-plaqué
Sperrholz
contrachapado

Y34 noce
walnut

Y39 frassino nero
black ash

telaio / structure / châssis / Gestell / bastidor

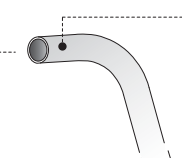
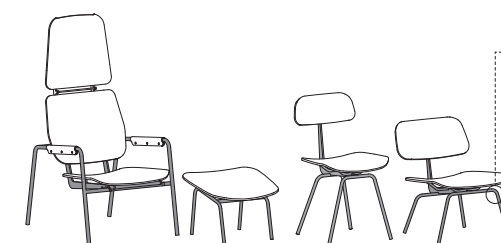

acciaio verniciato
powder coating steel
acier peint
lackierter Stahl
acero pintado

C12 bianco
white

C21 seta
silk

C23 corda
ecru

C30 ghisa
cast-iron

C14 antracite
anthracite

C08 nero
black

C18 verde
green

C26 corten
corten

C29 bronzo
bronze

cuscino / cushion / coussin / Kissen / cojin

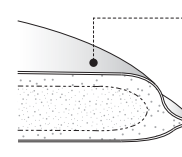
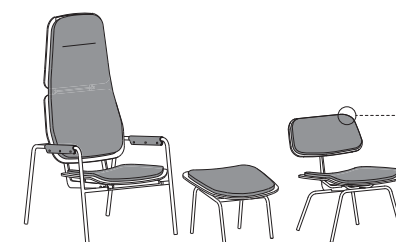

cuoio
cow-hide
cuir
Kernleder
cuero

F01 tabacco
tobacco

F03 corteccia
bark

F02 nero
black

dimensioni / dimensions

sedie / chairs / chaises / Stühle / sillas

K

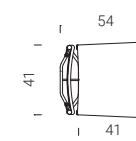
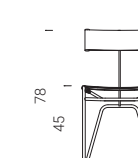

W

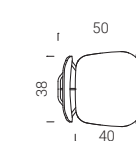
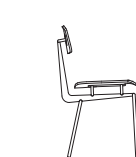
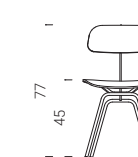

L

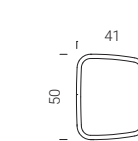
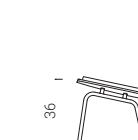
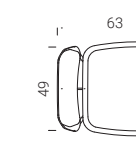
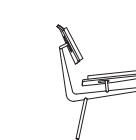
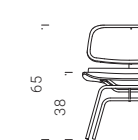

GL

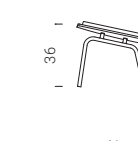
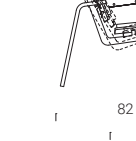
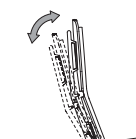
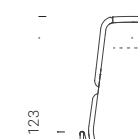



viking K
VK01

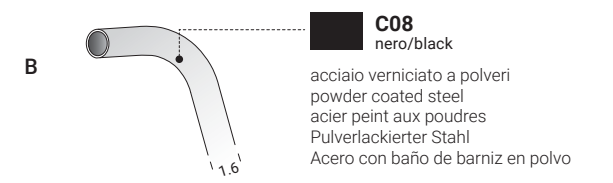
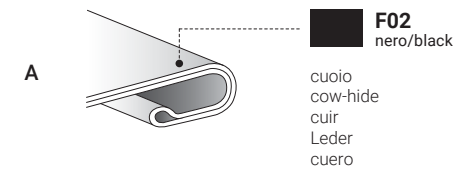
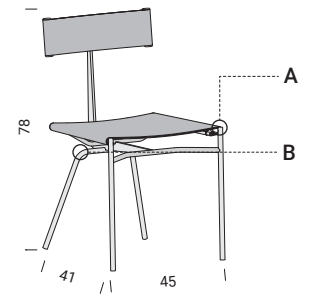

collection info
pg. 230





viking W
VK02

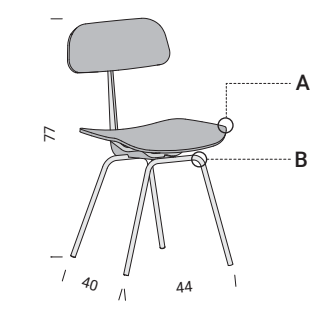

- Y34**
noce/walnut
- Y39**
frassino nero/black ash
- A**
multistrato
plywood
contre-plaqué
Sperrholz
contrachapado
- B**
C08
nero/black
acciaio verniciato a polveri
powder coated steel
acier peint aux poudres
Pulverlackierter Stahl
Acero con baño de barniz en polvo

collection info
pg. 230



viking L
VK03

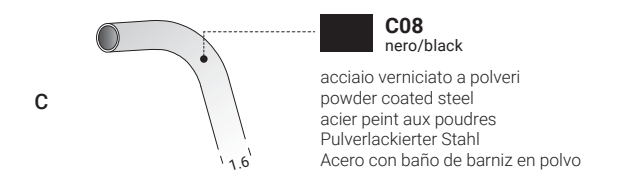
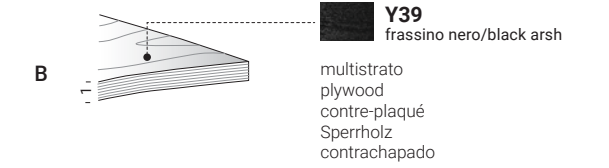
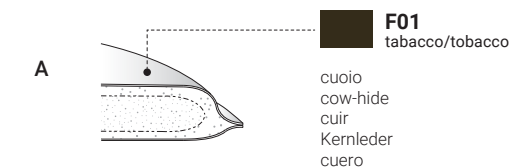
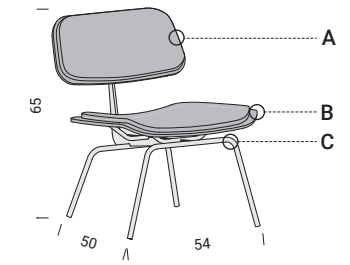

collection info
pg. 230



viking GL
VK04

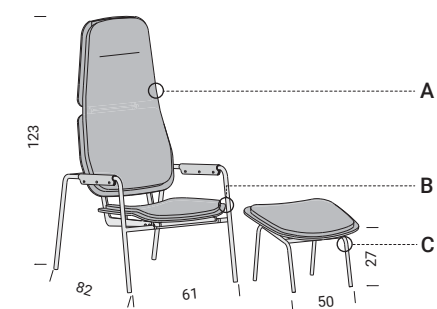

A

F01
tabacco/tobacco

cuoio
cow-hide
cuir
Kernleder
cuero

B

Y34
noce/walnut

multistrato
plywood
contre-plaqué
Sperrholz
contrachapado

C

C08
nero/black

acciaio verniciato a polveri
powder coated steel
acier peint aux poudres
Pulverlackierter Stahl
Acero con baño de barniz en polvo

collection info
pg. 230





danske C

L'acciaio e il legno vengono plasmati esaltando le loro caratteristiche strutturali ed estetiche. Le singole geometrie tridimensionali di legno e acciaio si compenetrano in uniche superfici. Le parti in legno massiccio sono protette con vernice all'acqua opaca antigraffio, mentre le parti in acciaio sono verniciate a polveri.

Steel and wood are shaped to emphasise their structural and aesthetic characteristics. The individual, three-dimensional geometries of the wood and steel permeate in single surfaces. The solid wood parts are protected with matt, scratch-proof water-based varnish, while the steel parts are powder painted.

L'acier et le bois sont façonnés en exaltant leurs caractéristiques structurelles et esthétiques. Les différentes géométries tridimensionnelles du bois et de l'acier s'interpénètrent en surfaces uniques. Les parties en bois massif sont protégées avec du verni à l'eau opaque résistant aux rayures, alors que les parties en acier sont vernies par poudres.

Stahl und Holz sind so geformt, dass ihre strukturellen und ästhetischen Eigenschaften unterstrichen werden. Die einzelnen, dreidimensionalen Formen von Holz und Stahl durchdringen zusammen zu einzigen Oberflächen. Die Teile aus Massivholz sind mit einer Schicht aus mattem und kratzfesten Wasserlack geschützt und die Teile aus Stahl sind pulverlackiert.

El acero y la madera se modelan exaltando sus características estructurales y estéticas. Las geometrías tridimensionales individuales de la madera y el acero se compenetran en superficies únicas. Las piezas de madera maciza están protegidas con barniz mate al agua resistente a los arañazos, mientras que las piezas de acero están tratadas con barniz en polvo.



materiali / materials



legno massiccio
solid wood
bois massif
Massivholz
madera maciza



acciaio
steel
acier
Stahl
acero

Le materie prime che costituiscono il sistema danske C derivano da un processo di riutilizzo e sono a loro volta riciclabili.

The primary materials used in the system danske C are sourced from a reuse process, and are in turn recyclable.

Les matières premières qui composent le système danske C dérivent d'un processus de réutilisation et sont à leur tour recyclables.

Die Rohstoffe für das System danske C entstammen einem Wiederverwertungsprozess und sind Ihrerseits wiederum recyclebar.

Las materias primas que constituyen el sistema danske C proceden de un proceso de reutilización y son, a su vez, reciclables.

finiture / finishes

fondello e schienale / seat and back / siège et dossier / Sitzfläche und Rückenlehne / asiento y respaldo

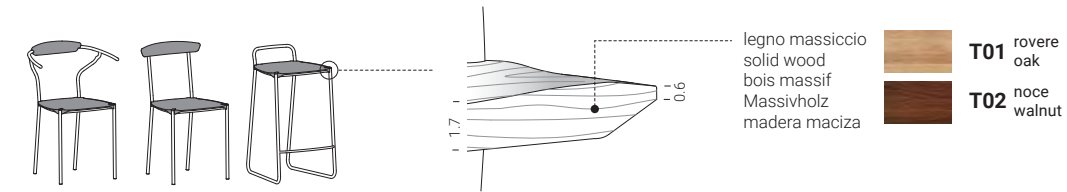

telaio / structure / châssis / Gestell / bastidor

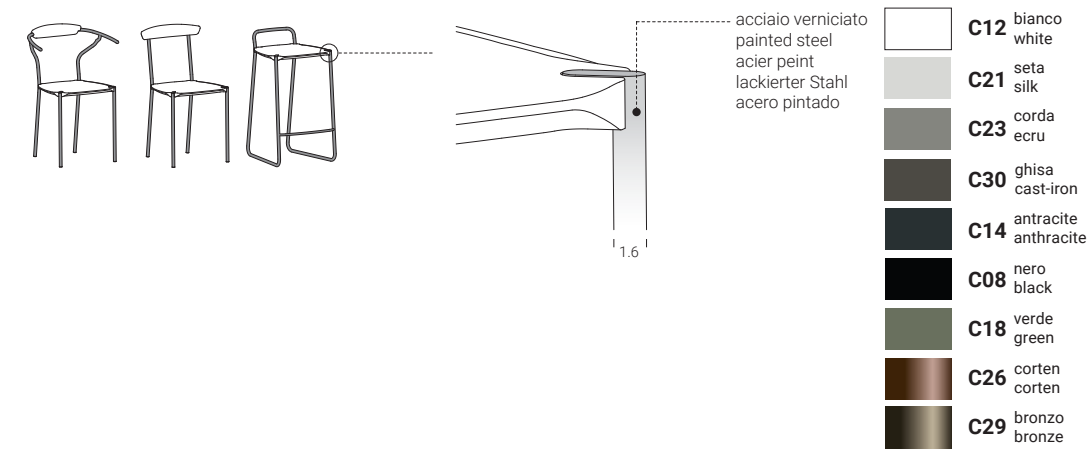

dimensioni / dimensions

sedie / chairs / chaises / Stühle / sillas

C1

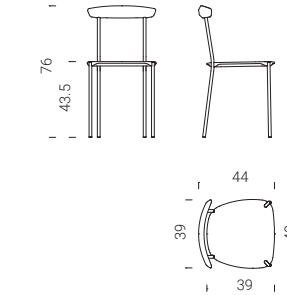

C2

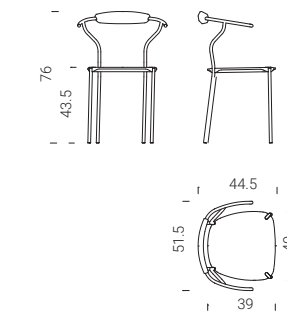

C3

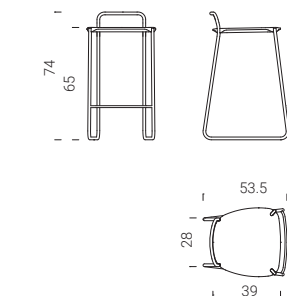



danske C1
DC01

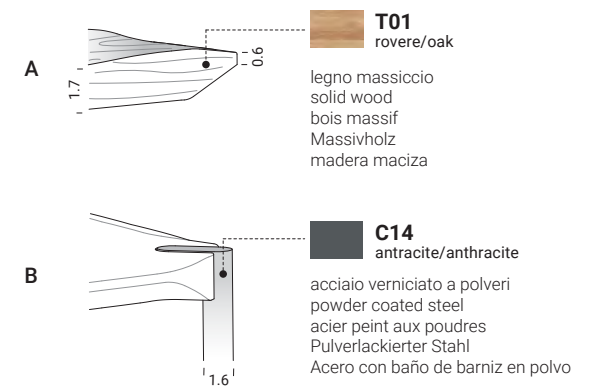
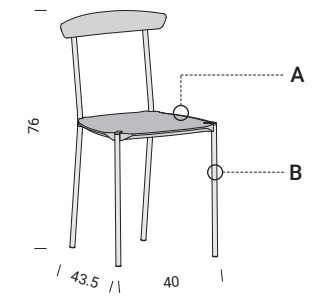

collection info
pg. 244



danske C2
DC02

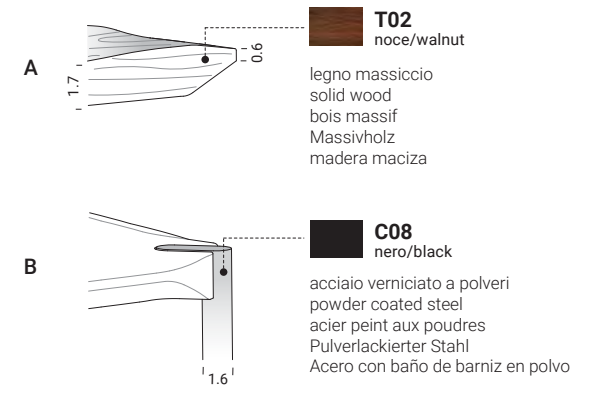
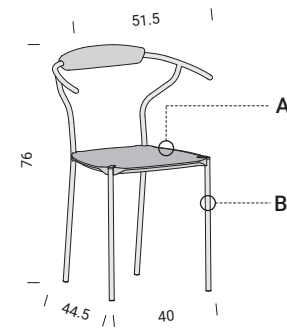

collection info
pg. 244





danske C3
DC04

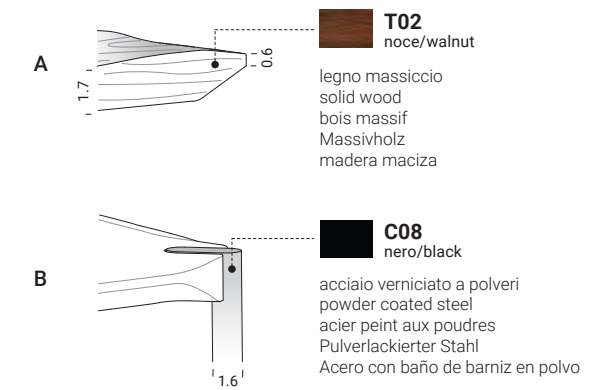
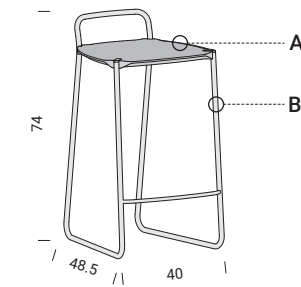

collection info
pg. 244



danske C3
DC03

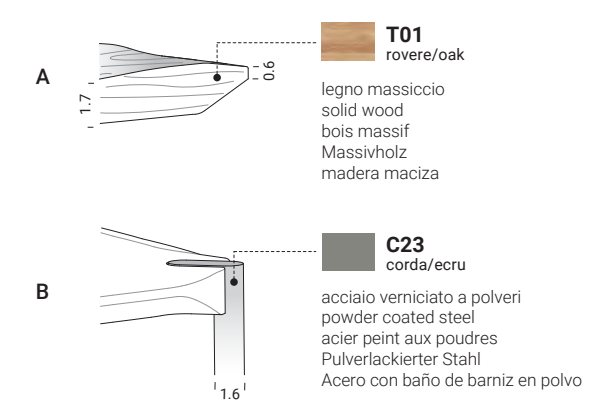
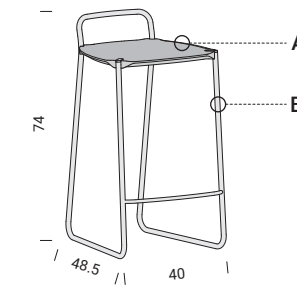

collection info
pg. 244

multimedia

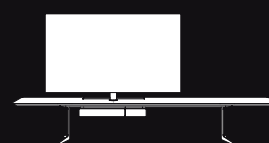

connect

pg. 258



spin360

pg. 272

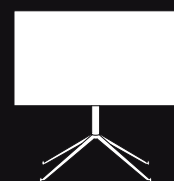

apollo

pg. 226

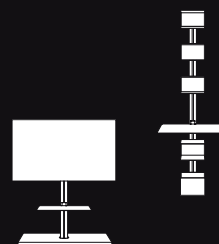

girogiro-system

pg. 278



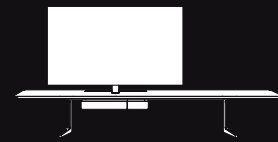

connect

Supporto pensato per installare le Tv di nuova generazione a parete o in centro stanza con la massima flessibilità. Il sistema di integrazione cavi studiato da extendo consente di nascondere completamente i cavi lasciando libertà di rotazione di 360° della Tv. Il supporto rotante e il contenimento di apparati multimediali nella parte sottostante sono accessori.

This is a TV support column designed to host new generation TV installations either mounted on the wall or in the centre of the room with the utmost flexibility. The cable integration system designed by extendo makes it possible to completely conceal cables enabling the TV to freely rotate a full 360°. The turntable swivel base and the multimedia device cable containment system in the lower part of the support column are accessories.

Support conçu pour installer les téléviseurs de nouvelle génération au mur ou au centre de la pièce avec une flexibilité maximale. Le système d'intégration des câbles, conçu par extendo, permet de cacher complètement les câbles en laissant la liberté de rotation de 360° du téléviseur. Le support pivotant et le récipient pour appareils multimédias dans la partie en dessous sont des accessoires.

Fernsehalterung für die Installation von TV-Geräten der neuesten Generation an der Wand oder in der Raummitte, für maximale Flexibilität bei der Positionierung. Dank der von extendo entwickelten, integrierten Kabelführung lassen sich die Gerätekabel völlig verstecken, wobei das Gerät um 360 Grad schwenkbar bleibt. Die Drehhalterung und die unterhalb anzubringenden Fächer für Multimedia-Geräte sind als Zubehör erhältlich.

Soporte pensado para instalar televisores de nueva generación en la pared o en una posición central en el ambiente, con la máxima flexibilidad. El sistema de integración de cables estudiado por extendo, permite ocultar los cables por completo, dejando libertad de rotación de 360° para el televisor. Cuenta con accesorios en la parte de abajo: un soporte giratorio y un espacio para posicionar dispositivos multimedia.



i cavi della TV e di eventuali unità multimediali sono completamente nascosti. the TV and multimedia unit wires are completely hidden. les fils de la TV et des unités multimédias sont complètement dissimulés. Die Kabel des Fernsehers und der Multimedia sind vollkommen unsichtbar. los cables de la TV y de los sistemas multimedia quedan completamente ocultos.

supporto monitor universale per TV da 19 a 65 pollici. universal monitor support for TV from 19 to 65 inches. support moniteur universel pour TV de 19 à 65 pouces. Universal-Monitor-Halter für TV von 19 bis 65 Zoll. soporte de monitor universal para TV de 19 a 65 pulgadas.

materiali / materials



HPL+legno
HPL+wood
HPL+bois
HPL+Holz
HPL+madera



legno massiccio
solid wood
bois massif
Massivholz
madera maciza

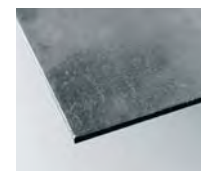

acciaio
steel
acier
Stahl
acero

Le materie prime che costituiscono il sistema connect derivano da un processo di riutilizzo e sono a loro volta riciclabili.

The primary materials used in the system connect are sourced from a reuse process, and are in turn recyclable.

Les matières premières qui composent le système connect dérivent d'un processus de réutilisation et sont à leur tour recyclables.

Die Rohstoffe für das System connect entstammen einem Wiederverwertungsprozess und sind Ihrerseits wiederum recyclebar.

Las materias primas que constituyen el sistema connect proceden de un proceso de reutilización y son, a su vez, reciclables.

finiture / finishes

top / top / plateaux / Platte / plano

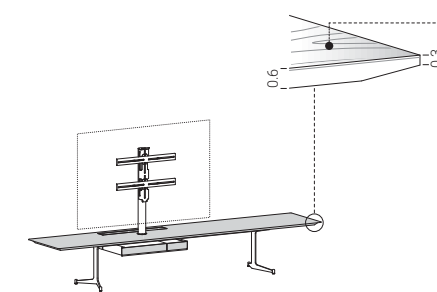

- HPL **L03** bianco white
- FENIX NTM** **L08** grigio Londra London grey
- FENIX NTM** **L06** nero black
- HPL + legno/wood **Y36** rovere oak
- bois/Holz **Y34** noce walnut
- madera **Y37** rovere affumicato smoked oak
- Y39** frassino nero black ash
- HPL + ottone/brass **C31** ottone brass
- laiton/Messing latón
- eco-touch** **N01** sabbia sand
- eco-touch** **N02** basalto basalt

telaio / structure / châssis / Gestell / bastidor

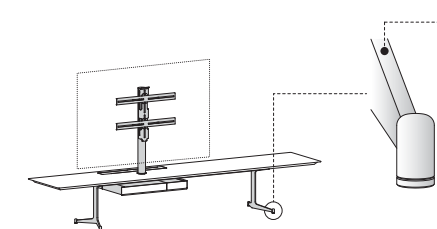

- acciaio verniciato powder coating steel **C12** bianco white
- acier peint **C21** seta silk
- lackierter Stahl **C23** corda ecru
- acero pintado **C30** ghisa cast-iron
- C14** antracite anthracite
- C08** nero black
- C18** verde green
- C26** corten corten
- C29** bronzo bronze

dimensioni / dimensions

panca porta TV / bench TV support / banc TV / Fernsehbank / banco de TV

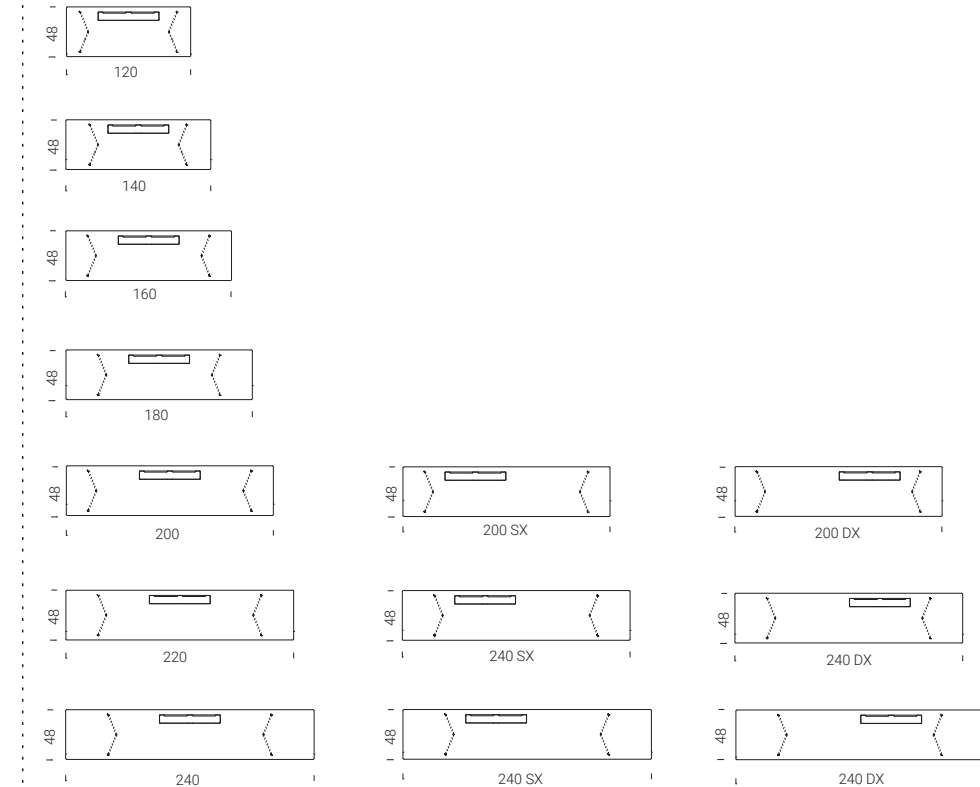

accessori / accessories / accessoires / Zubehör / accesorios

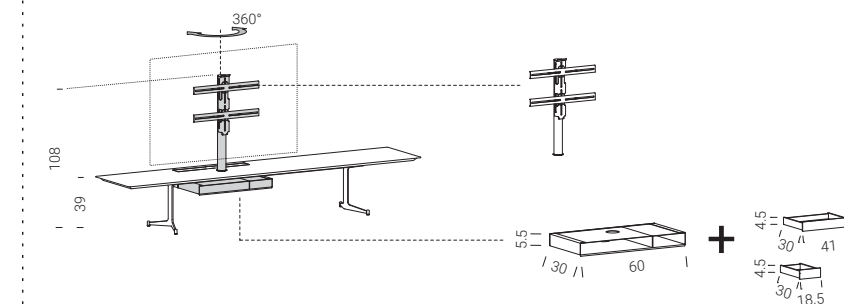

verificare a listino geometrie e finiture / check profiles and finishings in the price list / vérifier sur la liste de prix les géométries et les finitions / Siehe Preisliste für Ausführungen und Oberflächen / averiguar geometrías y acabados en la lista



connect
CN01

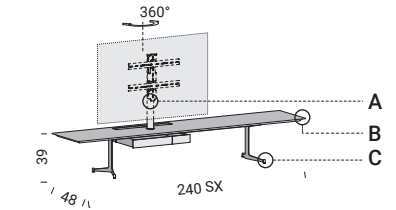

- A**

C08
nero/black
acciaio verniciato a polveri
powder coated steel
acier peint aux poudres
Pulverlackierter Stahl
Acero con baño de barniz en polvo
- B**

Y39
frassino nero/black ash
HPL impiallacciato
veneered HPL
HPL plaqué
HPL mit Furnier
HPL chapado
- C**

C08
nero/black
acciaio verniciato a polveri
powder coated steel
acier peint aux poudres
Pulverlackierter Stahl
Acero con baño de barniz en polvo

collection info
pg. 258

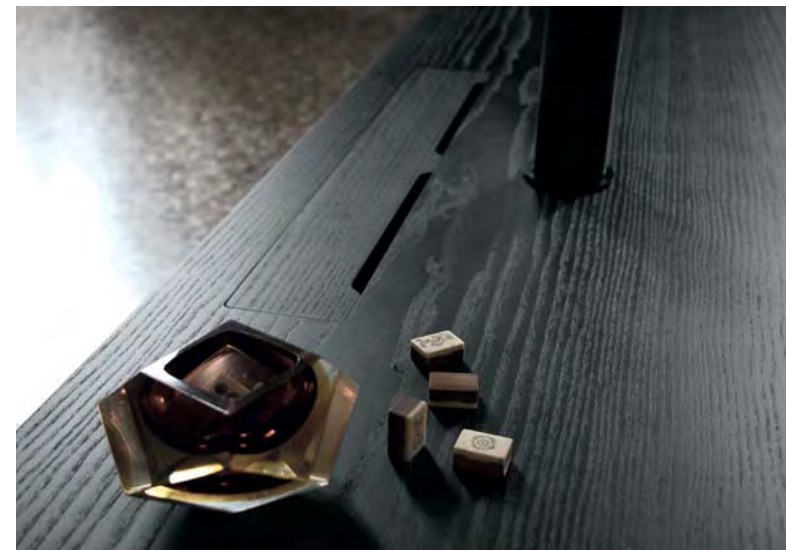



connect
CN02

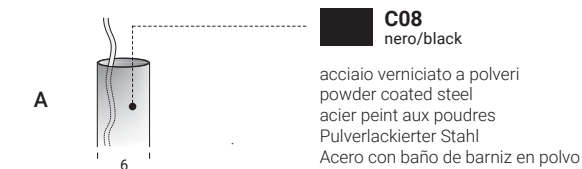
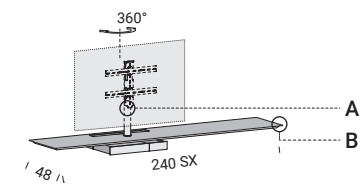

C08
nero/black

acciaio verniciato a polveri
powder coated steel
acier peint aux poudres
Pulverlackierter Stahl
Acero con baño de barniz en polvo

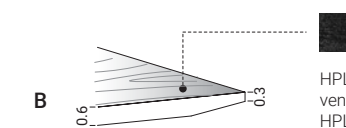

Y39
frassino nero/black ash

HPL impiallacciato
veneered HPL
HPL plaqué
HPL mit Furnier
HPL chapado

collection info
pg. 258

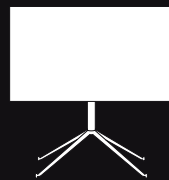

apollo

Desideravamo disegnare un supporto che si integrasse al meglio con il design essenziale degli ultimi modelli Tv. Apollo pur essendo composto da pochi elementi che ne evidenziano la purezza geometrica, consente la rotazione di 360°, l'occultamento dei cavi e la possibilità di aggiungere accessori porta decoder e sound bar.

We had the intention to design a TV support column that integrates at best with the essential design of the latest TV models. Although Apollo consists of only a few elements that enhance its geometrical purity, it rotates 360°, the concealing of cables along with the possibility to add TV decoder and sound bar support accessories.

Nous souhaitions dessiner un support qui s'intègre au mieux avec le design essentiel des derniers modèles de téléviseurs. Apollo, même s'il est composé de peu d'éléments qui mettent en évidence sa pureté géométrique, permet la rotation de 360°, la dissimulation des câbles et la possibilité d'ajouter des accessoires comme le porte-décodeur et la barre audio.

Unser Anliegen bestand darin, einen Fernsehständer zu entwerfen, der optimal auf das essentielle Design der neuesten TV-Modelle abgestimmt ist. Apollo setzt auf einen essentiellen Aufbau aus wenigen Elementen und besticht durch eine schlichte Optik. Er erlaubt eine Drehung des Geräts um 360 Grad, bietet unsichtbare Kabelverlegung und auf Wunsch zusätzliche Ablagen für Decoder und Soundbar als Zubehör.

Nuestro deseo era diseñar un soporte que se integrara de la mejor forma con el diseño esencial de los últimos modelos de televisores. Apollo, que consta de pocos elementos que ponen de relieve su pureza geométrica, permite la rotación de 360°, ocultar los cables y la posibilidad de añadir accesorios porta codificador y barra de sonido.



i cavi della TV e di eventuali unità multimediali sono completamente nascosti. the TV and multimedia unit wires are completely hidden. les fils de la TV et des unités multimédias sont complètement dissimulés. Die Kabel des Fernsehers und der Multimedia sind vollkommen unsichtbar. los cables de la TV y de los sistemas multimedia quedan completamente ocultos.

supporto monitor universale per TV da 19 a 65 pollici. universal monitor support for TV from 19 to 65 inches. support moniteur universel pour TV de 19 à 65 pouces. Universal-Monitor-Halter für TV von 19 bis 65 Zoll. soporte de monitor universal para TV de 19 a 65 pulgadas.

materiali / materials



acciaio
steel
acier
Stahl
acero

Le materie prime che costituiscono il sistema apollo derivano da un processo di riutilizzo e sono a loro volta riciclabili.

The primary materials used in the system apollo are sourced from a reuse process, and are in turn recyclable.

Les matières premières qui composent le système apollo dérivent d'un processus de réutilisation et sont à leur tour recyclables.

Die Rohstoffe für das System apollo entstammen einem Wiederverwertungsprozess und sind Ihrerseits wiederum recyclebar.

Las materias primas que constituyen el sistema apollo proceden de un proceso de reutilización y son, a su vez, reciclables.

finiture / finishes

telaio / structure / châssis / Gestell / bastidor

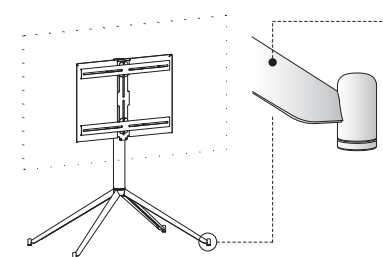

acciaio verniciato
powder coating steel
acier peint
lackierter Stahl
acero pintado

- C12 bianco white
- C21 seta silk
- C23 corda ecru
- C30 ghisa cast-iron
- C14 antracite anthracite
- C08 nero black

dimensioni / dimensions

porta TV / TV support / porte TV / Fernsehstand / soporte TV

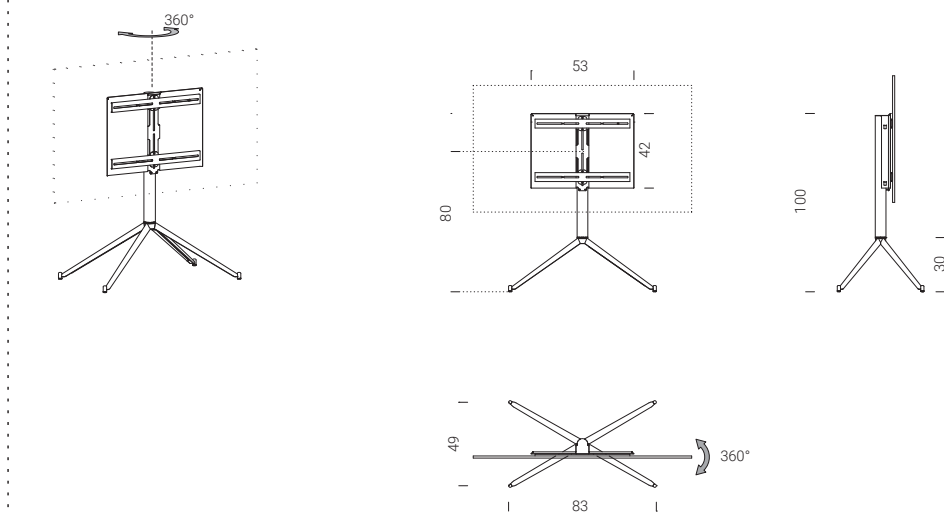

accessori / accessories / accessoires / Zubehör / accesorios

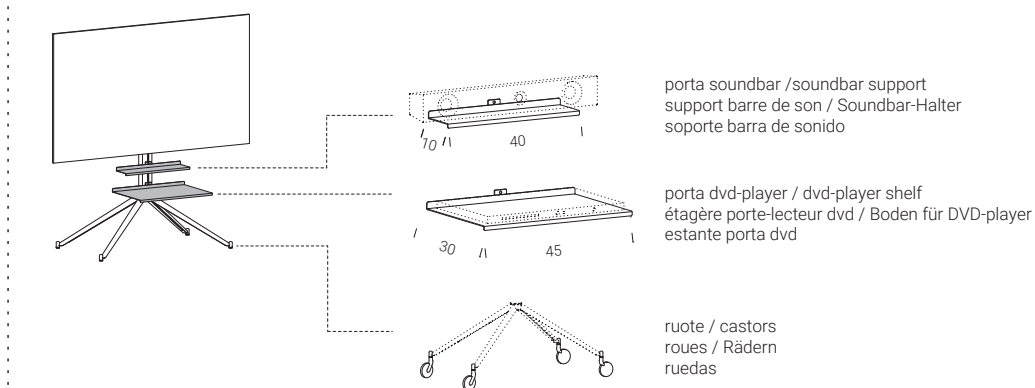

verificare a listino geometrie e finiture / check profiles and finishings in the price list / vérifier sur la liste de prix les géométries et les finitions / Siehe Preisliste für Ausführungen und Oberflächen / averiguar geometrías y acabados en la lista



apollo
AP02

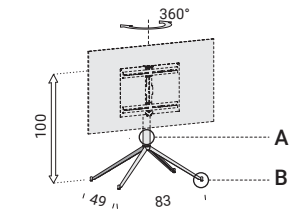

A

C14
antracite/anthracite

acciaio verniciato a polveri
powder coated steel
acier peint aux poudres
Pulverlackierter Stahl
Acero con baño de barniz en polvo

B

C14
antracite/anthracite

acciaio verniciato a polveri
powder coated steel
acier peint aux poudres
Pulverlackierter Stahl
Acero con baño de barniz en polvo

collection info
pg. 266





spin360

Spin 360 è un supporto TV disegnato e progettato per una perfetta integrazione con i monitor dal design più sofisticato. Nascondere i cavi completamente al suo interno e orientare la colonna a 360 gradi, garantisce massima funzionalità e purezza di disegno. Spin 360 è disponibile nella versione con base in acciaio spessore 6mm, con contenitore per unità multimediali aperto o chiuso, in due altezze distinte H=100 / 120 cm, (altezze nel punto medio del monitor).

Spin 360 is a TV support designed and manufactured for perfect integration with the most sophisticated monitor designs. It completely hides wires within and the column can be turned 360 degrees, guaranteeing maximum functionality and clean design. Spin 360 is available in a version with a 6mm thick steel base, with a container for multimedia units opened or closed, in two distinct heights H=100 / 120 cm, (heights at average height of the monitor).

Spin 360 est un support pour TV dessiné et conçu pour une intégration parfaite avec les écrans aux designs les plus sophistiqués. Pour un maximum de fonctionnalité et de pureté du dessin dissimuler les fils complètement à l'intérieur et orienter la colonne à 360°. Spin 360 est disponible dans la version avec base en acier, épaisseur 6 mm, avec module de rangement pour unités multimédias ouvert ou fermé, disponible dans deux hauteurs distinctes H=100/120 cm, (hauteurs mesurées au point médian de l'écran).

Spin 360 ist ein TV-Halter, der für eine perfekte Integration von hoch entwickelten Bildschirmen entworfen wurde. Die vollständige Unterbringung der Kabel im Halter und die Drehmöglichkeit der Säule um 360 Grad, bieten höchste Zweckmäßigkeit und ein klares Design. Spin 360 ist in der Version mit einem Fuß aus 6 mm starkem Stahl, einer multimedialen, offenen oder geschlossenen Einheit, in zwei unterschiedlichen Höhen von 100 oder 120 cm (Höhe des Mittelpunktes des Bildschirms) erhältlich.

Spin 360 es un soporte de TV diseñado y desarrollado para una integración perfecta con la pantalla de diseño más sofisticado. Ocultar los cables completamente en su interior y orientar la columna a 360 grados, garantiza la máxima durabilidad y la pureza del diseño. Spin 360 está disponible en versión con base de acero de 6 mm de grosor, con compartimento para sistemas multimedia abierto o cerrado, en dos alturas diferentes H = 100/120 cm, (altura desde el punto central de la pantalla).



la base è dotata di pattini in teflon per un facile spostamento. the base is equipped with Teflon slides for easy movement. la base est munie de patins en téflon afin de faciliter le déplacement. Für eine einfache Verschiebung ist die Basis mit Teflon-Kufen ausgestattet. la base cuenta con patines de teflón para colocarla fácilmente.

i cavi della TV e di eventuali unità multimediali sono completamente nascosti. the TV and multimedia unit wires are completely hidden. les fils de la TV et des unités multimédias sont complètement dissimulés. Die Kabel des Fernsehers und der Multimedia sind vollkommen unsichtbar. los cables de la TV y de los sistemas multimedia quedan completamente ocultos.

supporto monitor universale per TV da 19 a 65 pollici. universal monitor support for TV from 19 to 65 inches. support moniteur universel pour TV de 19 à 65 pouces. Universal-Monitor-Halter für TV von 19 bis 65 Zoll. soporte de monitor universal para TV de 19 a 65 pulgadas.



materiali / materials

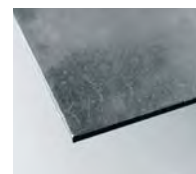

acciaio
steel
acier
Stahl
acero

Le materie prime che costituiscono il sistema spin360 derivano da un processo di riutilizzo e sono a loro volta riciclabili.

The primary materials used in the system spin360 are sourced from a reuse process, and are in turn recyclable.

Les matières premières qui composent le système spin360 dérivent d'un processus de réutilisation et sont à leur tour recyclables.

Die Rohstoffe für das System spin360 entstammen einem Wiederverwertungsprozess und sind Ihrerseits wiederum recyclebar.

Las materias primas que constituyen el sistema spin360 proceden de un proceso de reutilización y son, a su vez, reciclables.

finiture / finishes

telaio / structure / châssis / Gestell / bastidor

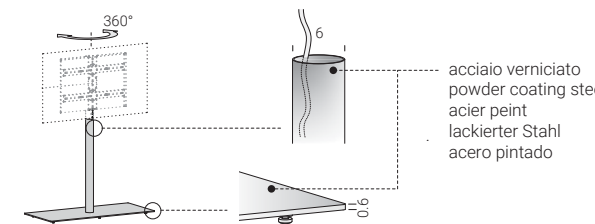

acciaio verniciato
powder coating steel
acier peint
lackierter Stahl
acero pintado

- C12** bianco white
- C21** seta silk
- C23** corda ecru
- C30** ghisa cast-iron
- C14** antracite anthracite
- C08** nero black

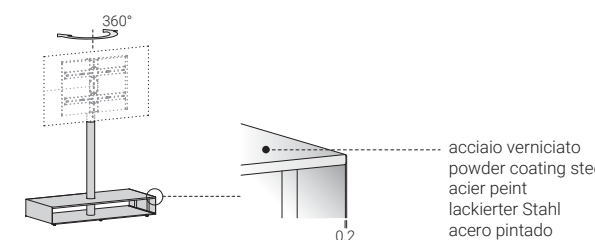

acciaio verniciato
powder coating steel
acier peint
lackierter Stahl
acero pintado

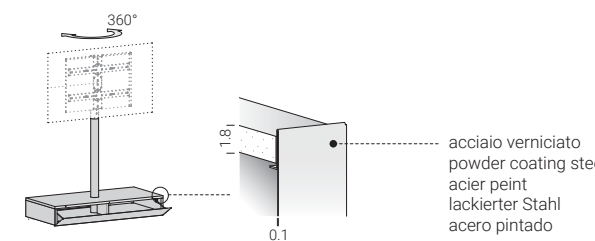

acciaio verniciato
powder coating steel
acier peint
lackierter Stahl
acero pintado

dimensioni / dimensions

porta TV / TV support / porte TV / Fernsehstand / soporte TV

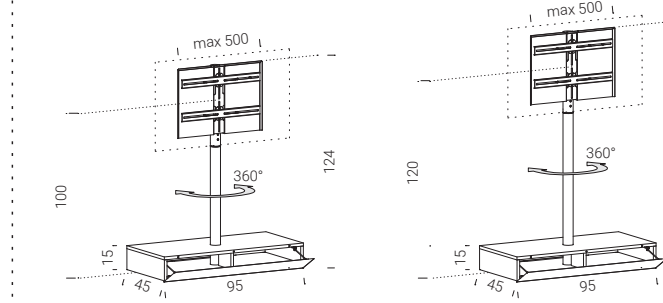
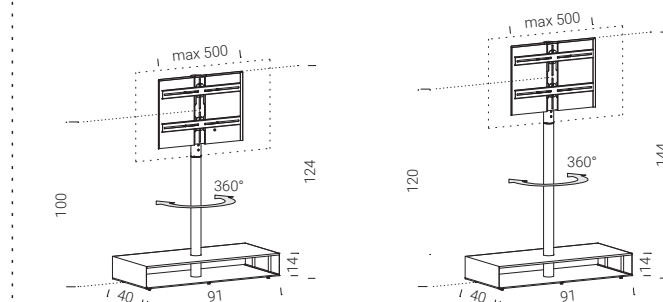
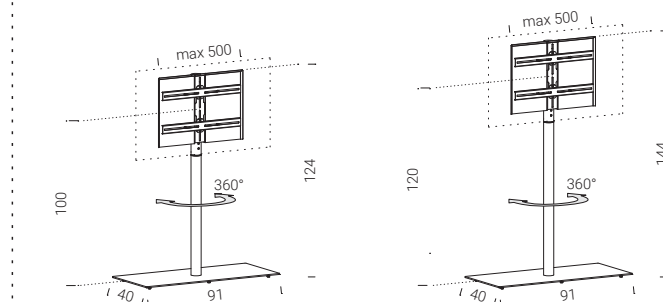

accessori / accessories / accessoires / Zubehör / accesorios

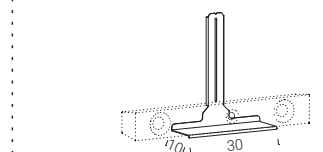

porta soundbar
soundbar support
support barre de son
Soundbar-Halter
soporte barra de sonido



ripetitore di segnale per telecomandi
signal relay for remote control
répéteur de signal pour télécommandes
Signalverstärker für Fernsteuerung
repetidor de señal para mando a distancia

⚠ verificare a listino geometrie e finiture / check profiles and finishings in the price list / vérifier sur la liste de prix les géométries et les finitions / Siehe Preisliste für Ausführungen und Oberflächen / averiguar geometrías y acabados en la lista



spin360
SN01

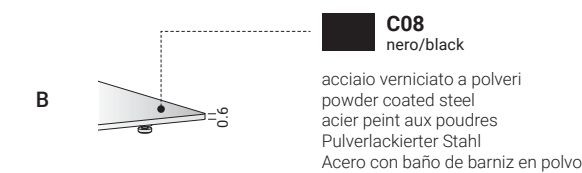
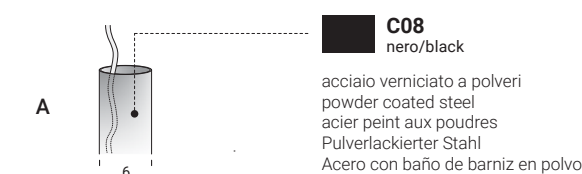
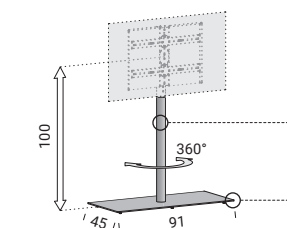

C08
nero/black
acciaio verniciato a polveri
powder coated steel
acier peint aux poudres
Pulverlackierter Stahl
Acero con baño de barniz en polvo

C08
nero/black
acciaio verniciato a polveri
powder coated steel
acier peint aux poudres
Pulverlackierter Stahl
Acero con baño de barniz en polvo

collection info
pg. 272



La copertura in acciaio a rimozione rapida, consente di nascondere nella parte posteriore del monitor, cavi e prese. Il supporto regolabile per sound bar è un accessorio utilizzabile nei 6 modelli porta TV.

The fast-removal steel covering allows the rear part of the monitor, cables and sockets to be easily hidden. The adjustable support for the sound bar is an accessory used in the 6 TV support models.

La couverture en acier à démontage rapide, permet de dissimuler les fils et les prises à l'arrière de l'écran. Le support réglable pour barre de son est un accessoire utilisable avec les 6 modèles porte TV.

Die einfach zu entfernende Stahlabdeckung ermöglicht die sichtgeschützte Unterbringung der Kabel und Stecker an der Rückseite des Bildschirms. Der einstellbare Sound Bar-Halter kann bei den 6 Modellen für TV-Halter eingesetzt werden.

La cubierta de acero de extracción rápida permite ocultar, por detrás de la pantalla, cables y tomas. El soporte ajustable para la barra de sonido es un accesorio utilizable en los 6 modelos de soporte de TV.



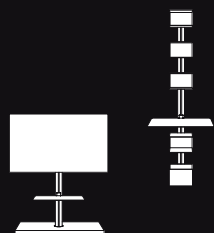

girogiro-system

Le colonne girogiro con base 40x40 sono accessoriabili con elementi porta libri, riviste, CD. La versione girogiro con base 80x40, l'asta telescopica extendo e il profilo a parete extendo, sono prodotti accessoriabili con staffa supporto monitor universale, ripiani per unità multimediali, ripiani per libri, riviste, DVD, CD. Le clip ferma-cavi in dotazione con la staffa monitor consentono di effettuare il cablaggio all'esterno del profilo.

The girogiro columns with a 40x40 base can be accessorised with book, magazine and CD shelving elements. The girogiro version with an 80x40 base, the Extendo telescopic pole and Extendo wall profile are products easily accessorised with a universal monitor support bracket, shelving for multimedia units or shelving for books, magazines, DVDs and CDs. The cable-tie clips supplied with the monitor bracket enable wiring outside the profile.

Les colonnes girogiro avec base 40x40 peuvent être équipées avec des éléments porte-livres, revues, CD. La version girogiro avec base 80x40, la tige télescopique extendo et le profilé mural extendo sont des produits pouvant être équipés de fixation de support de moniteur universel, d'étagères pour unités multimédia, d'étagères pour livres, revues, DVD, CD. Le clip serre-câble fourni avec la fixation de support de moniteur permet d'effectuer le câblage à l'extérieur du profilé.

Die Säulen girogiro mit einem 40x40 Fuß können mit Halter für Bücher, Zeitschriften, CDs ausgestattet werden. Die Version girogiro mit Fuß 80x40, die extendo Teleskopstange und das extendo Wandprofil, können mit Universal-Monitor-Halter, Fächer für multimediale Geräte, Fächer für Bücher, Zeitschriften, DVD und CD ausgestattet werden. Die zusammen mit dem Monitorhalter gelieferte Kabelklemmen ermöglichen die Verkabelung an der Außenseite des Profils.

Las columnas girogiro con base de 40 x 40 se pueden equipar con elementos de almacenamiento de libros, revistas y CD. La versión girogiro con base de 80 x 40, la barra telescópica extendo y el perfil de sujeción a pared extendo son productos equipables con accesorios como el soporte de monitor universal o los estantes para libros, revistas, DVD o CD. El clip sujetacables que viene con el soporte de monitor permite efectuar el cableado por fuera del perfil.



la base è dotata di pattini in teflon per un facile spostamento.
the base is equipped with Teflon slides for easy movement.
la base est munie de patins en téflon afin de faciliter le déplacement.
Für eine einfache Verschiebung ist die Basis mit Teflon-Kufen ausgestattet.
la base cuenta con patines de teflón para colocarla fácilmente.

i cavi della TV e di eventuali unità multimediali sono completamente nascosti.
the TV and multimedia unit wires are completely hidden.
les fils de la TV et des unités multimédias sont complètement dissimulés.
Die Kabel des Fernsehers und der Multimedia sind vollkommen unsichtbar.
los cables de la TV y de los sistemas multimedia quedan completamente ocultos.

supporto monitor universale per TV da 19 a 65 pollici.
universal monitor support for TV from 19 to 65 inches.
support moniteur universel pour TV de 19 à 65 pouces.
Universal-Monitor-Halter für TV von 19 bis 65 Zoll.
soporte de monitor universal para TV de 19 a 65 pulgadas.



materiali / materials

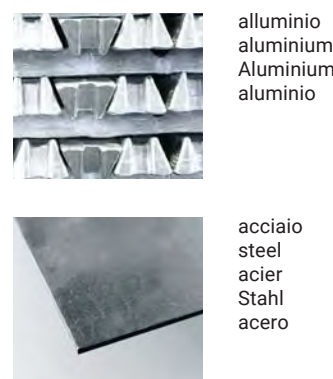

alluminio
aluminium
Aluminium
aluminio

acciaio
steel
acier
Stahl
acero

Le materie prime che costituiscono il sistema girogiro-system derivano da un processo di riutilizzo e sono a loro volta riciclabili.

The primary materials used in the system girogiro-system are sourced from a reuse process, and are in turn recyclable.

Les matières premières qui composent le système girogiro-system dérivent d'un processus de réutilisation et sont à leur tour recyclables.

Die Rohstoffe für das System girogiro-system entstammen einem Wiederverwertungsprozess und sind Ihrerseits wiederum recyclebar.

Las materias primas que constituyen el sistema girogiro-system proceden de un proceso de reutilización y son, a su vez, reciclables.

finiture / finishes

telaio / structure / châssis / Gestell / bastidor

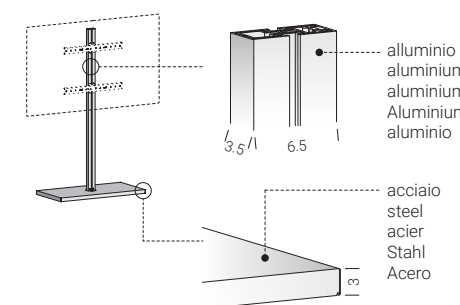

verniciatura a polveri
powder coating
peinture en poudres
Pulverlackierung
pintura en polvo

- C12** bianco white
- C21** seta silk
- C30** ghisa cast-iron
- C08** nero black

system

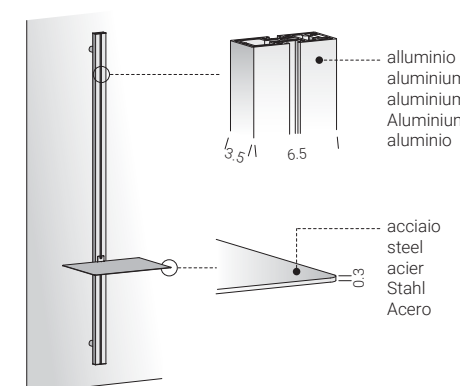

verniciatura a polveri
powder coating
peinture en poudres
Pulverlackierung
pintura en polvo

- C12** bianco white
- C21** seta silk
- C30** ghisa cast-iron
- C08** nero black

dimensioni / dimensions

porta TV / TV support / porte TV / Fernsehstand / soporte TV girogiro 80x40

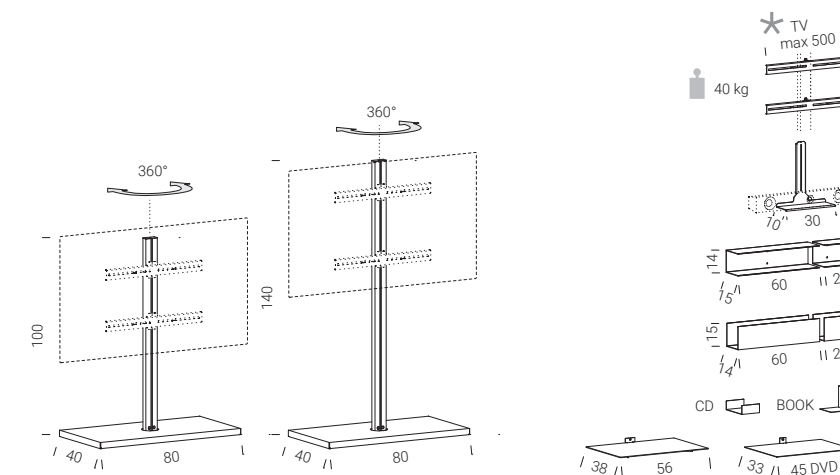

system

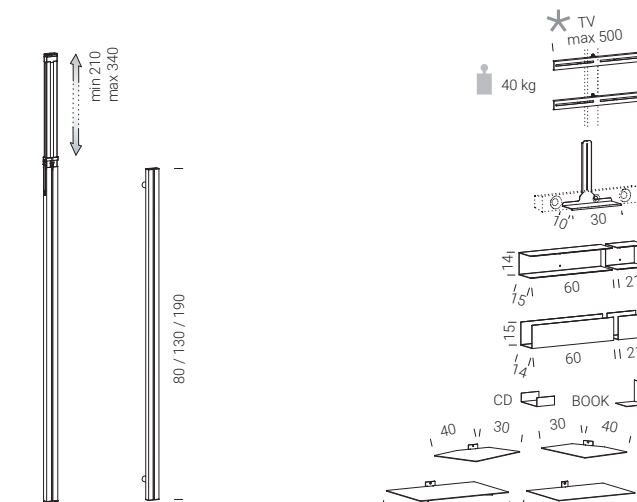

⚠ verificare a listino geometrie e finiture / check profiles and finishings in the price list / vérifier sur la liste de prix les géométries et les finitions / Siehe Preisliste für Ausführungen und Oberflächen / averiguar geometrías y acabados en la lista



system
SY55

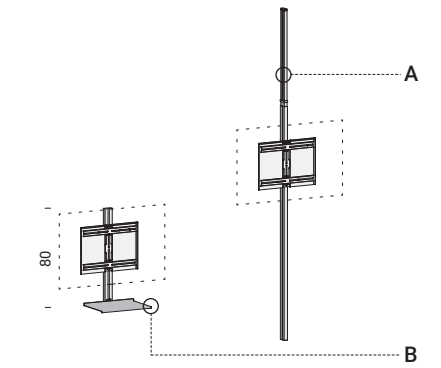

A

C08
nero/black

alluminio verniciato a polveri
powder coated aluminium
aluminium peint aux poudres
Pulverlackierter Aluminium
aluminio con baño de barniz en polvo

6.5 3.5

B

C08
nero/black

acciaio verniciato a polveri
powder coated steel
acier peint aux poudres
Pulverlackierter Stahl
acero con baño de barniz en polvo

0.3

collection info
pg. 278



girogiro
SY20C

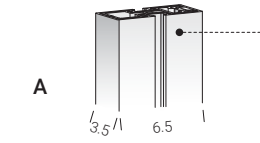
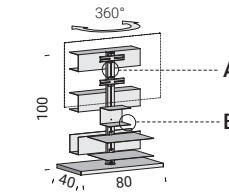

C08
nero/black
alluminio verniciato a polveri
powder coated aluminium
aluminium peint aux poudres
Pulverlackierter Aluminium
aluminio con baño de barniz en polvo

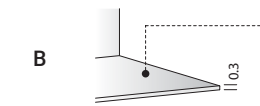

C08
nero/black
alluminio verniciato a polveri
powder coated aluminium
aluminium peint aux poudres
Pulverlackierter Aluminium
aluminio con baño de barniz en polvo

collection info
pg. 278



system
SY23

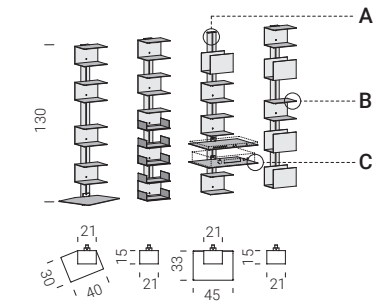

A

C08
nero/black

alluminio verniciato a polveri
powder coated aluminium
aluminium peint aux poudres
Pulverlackierter Aluminium
aluminio con baño de barniz en polvo

B

C08
nero/black

alluminio verniciato a polveri
powder coated aluminium
aluminium peint aux poudres
Pulverlackierter Aluminium
aluminio con baño de barniz en polvo

C

C08
nero/black

acciaio verniciato a polveri
powder coated steel
acier peint aux poudres
Pulverlackierter Stahl
acero con baño de barniz en polvo

collection info
pg. 278



system
SY18

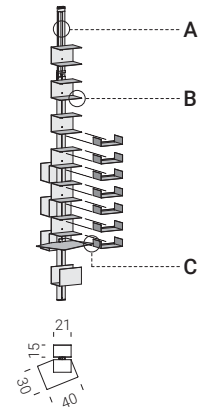

A

C08
nero/black
alluminio verniciato a polveri
powder coated aluminium
aluminium peint aux poudres
Pulverlackierter Aluminium
aluminio con baño de barniz en polvo

B

C08
nero/black
alluminio verniciato a polveri
powder coated aluminium
aluminium peint aux poudres
Pulverlackierter Aluminium
aluminio con baño de barniz en polvo

C

C08
nero/black
acciaio verniciato a polveri
powder coated steel
acier peint aux poudres
Pulverlackierter Stahl
acero con baño de barniz en polvo

collection info
pg. 278



system
SY17

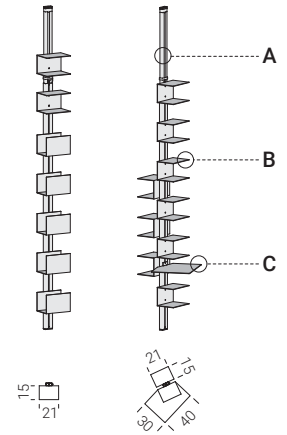

A

C12
bianco/white
alluminio verniciato a polveri
powder coated aluminium
aluminium peint aux poudres
Pulverlackierter Aluminium
aluminio con baño de barniz en polvo

B

C12
bianco/white
alluminio verniciato a polveri
powder coated aluminium
aluminium peint aux poudres
Pulverlackierter Aluminium
aluminio con baño de barniz en polvo

C

C12
bianco/white
acciaio verniciato a polveri
powder coated steel
acier peint aux poudres
Pulverlackierter Stahl
acero con baño de barniz en polvo

collection info
pg. 278

walk in closet

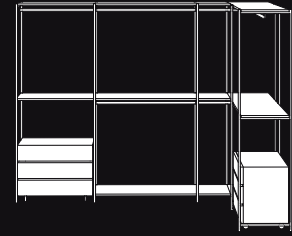

slide
pg. 290

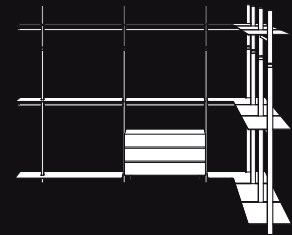

personal
pg. 306



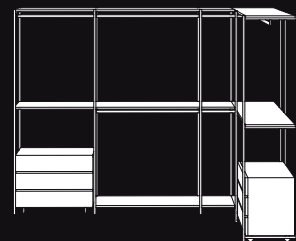

slide

Le coppie di profili verticali, i ripiani e le barre appenderia sono ordinabili al centimetro, ciò consente di progettare lo spazio desiderato in modo sartoriale senza extracosti di riduzioni.

The pairs of upright profiles, the shelves and hanging rails can be sized to the centimetre, making it possible to design a tailor-made space without the added cost of reductions.

Les paires de profils verticaux, les étagères et les barres porte-vêtements peuvent être commandées au centimètre, ceci permet d'organiser l'espace souhaité « sur mesure » sans coûts supplémentaires de réduction.

Die Paare vertikaler Profile, die Böden und die Aufhängestangen können zentimetergenau bestellt werden. Dadurch kann der gewünschte Raum ohne zusätzliche Kosten für Kürzungen maßgeschneidert geplant werden.

Los pares de perfiles verticales, estantes y barras de colgar se pueden pedir por centímetros, lo que permite diseñar el espacio deseado adaptándolos sin costos adicionales de reducción.



slide materials



alluminio
aluminium
Aluminium
aluminio

Le materie prime che costituiscono il sistema slide derivano da un processo di riutilizzo e sono a loro volta riciclabili.

The primary materials used in the system slide are sourced from a reuse process, and are in turn recyclable.

Les matières premières qui composent le système slide dérivent d'un processus de réutilisation et sont à leur tour recyclables.

Die Rohstoffe für das System slide entstammen einem Wiederverwertungsprozess und sind Ihrerseits wiederum recyclebar.

Las materias primas que constituyen el sistema slide proceden de un proceso de reutilización y son, a su vez, reciclables.



Il sistema di ancoraggio a "pinza" tra ripiani e profili verticali consente in fase progettuale il loro libero posizionamento in orizzontale e verticale. E' disponibile anche una versione di barra appenderia in posizione "terminale" che consente di spostare orizzontalmente la coppia profili verticali in ogni momento.

The "pincer" anchoring system attaching shelves to upright profiles means that during the design stage they can be freely positioned horizontally and vertically. The hanging rail is also available in an end-position version, so that the pair of upright profiles can be moved horizontally at any time.

Le système de fixation par « pince » entre les étagères et les profils verticaux permet, en phase de conception, leur positionnement libre dans le sens horizontal et vertical. Une version de barre porte-vêtements est également disponible en position « terminale ». Elle permet de déplacer la paire de profils verticaux dans le sens horizontal à tout moment.



Mit dem „Klemmen“-Verankerungssystem zwischen Böden und vertikalen Profilen können die Elemente bei der Planung frei horizontal oder vertikal positioniert werden. Es ist auch eine Version mit Aufhängestange in "Endposition" erhältlich, bei der das Paar vertikaler Profile jederzeit verschoben werden kann.

El sistema de anclaje de "pinza" entre los estantes y los perfiles verticales permite su libre colocación en horizontal y vertical durante la fase de diseño. También hay una versión de barra de colgar en posición "terminal" que permite colocar horizontalmente el par de perfiles verticales en todo momento.

finiture / finishes

spalle / support profiles / montants / Widerlage / perchas

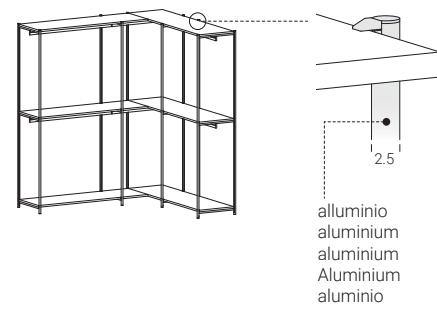

verniciatura a polveri
powder coating
peinture en poudres
Pulverlackierung
pintura en polvo

- C12** bianco white
- C21** seta silk
- C30** ghisa cast-iron
- C08** nero black

alluminio
aluminium
aluminium
Aluminium
aluminio

dimensioni / dimensions

spalle / support profiles / montants / Widerlage / perchas

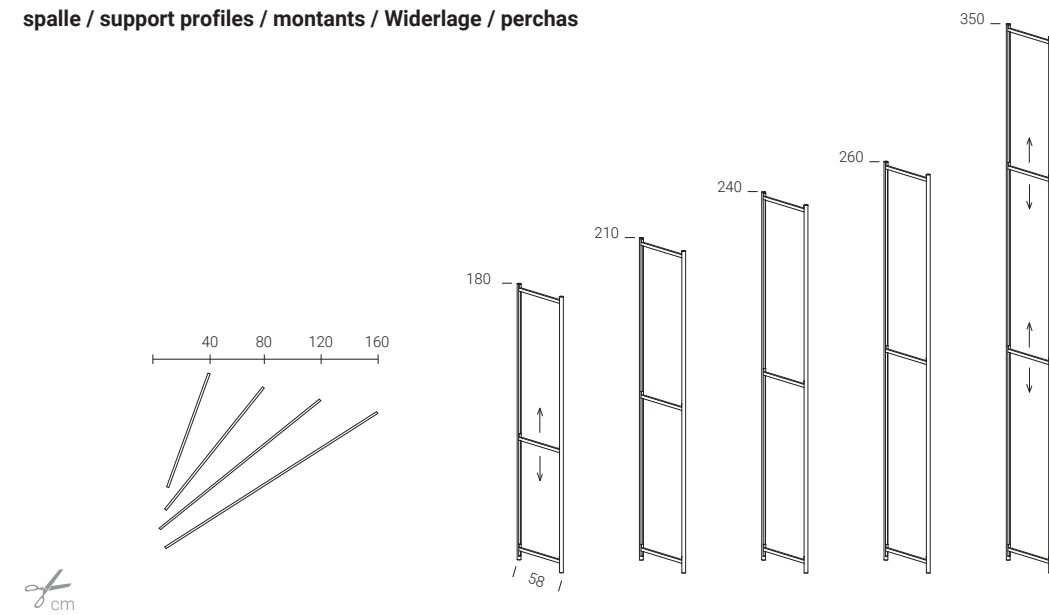

finiture / finishes

ripiani / shelves / étagères / Böden / estantes

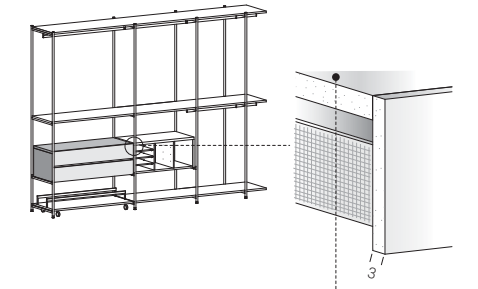

laccato
lacquered
laqué
lackiert
lacado

- Q05** bianco white
- Q16** seta silk
- Q17** corda ecru
- Q20** ghisa cast-iron
- Q04** nero black

melaminico
melamine
mélaminé
Melamin
melamina

- M03** bianco white
- M02** rovere moka moka oak

agglomerato ligneo
wood composite
aggloméré de bois
holzartiges Agglomerat
aglomerado de madera

ripiani / shelves / étagères / Böden / estantes

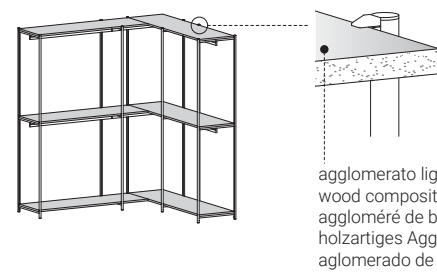

laccato
lacquered
laqué
lackiert
lacado

- Q05** bianco white
- Q16** seta silk
- Q17** corda ecru
- Q20** ghisa cast-iron
- Q04** nero black

melaminico
melamine
mélaminé
Melamin
melamina

- M03** bianco white
- M02** rovere moka moka oak

100 cm => 30 kg



ripiani / shelves / étagères / Böden / estantes

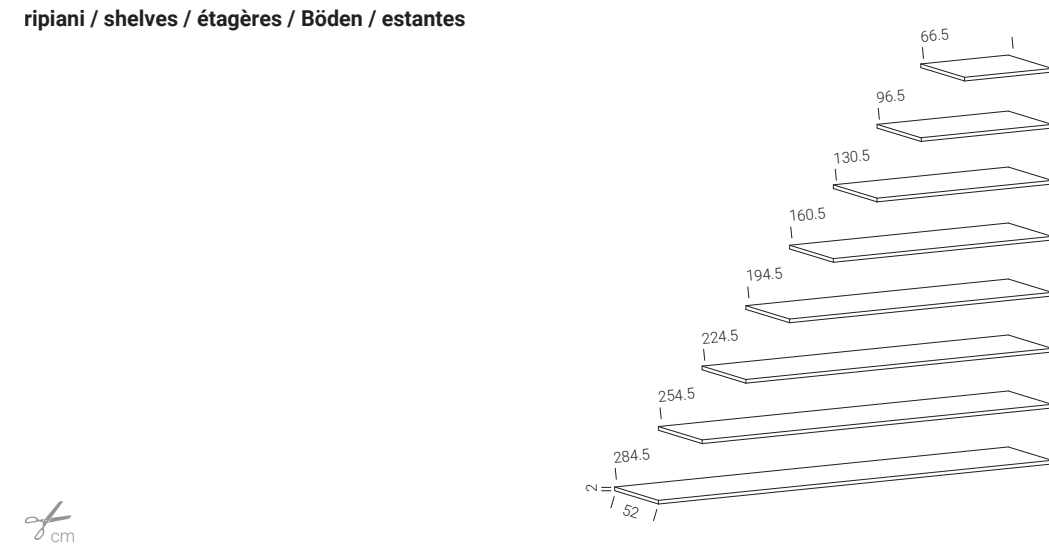

ripiani portascarpe su ruote / shoe rack shelves on casters / étagères porte-chaussures sur roues Böden schuhablage auf rollen / estantes portazapatos con ruedas

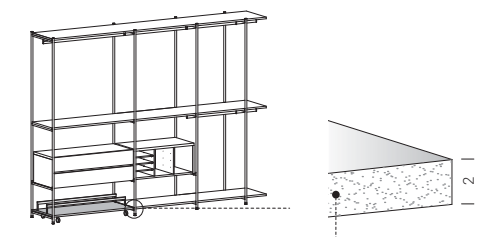

laccato
lacquered
laqué
lackiert
lacado

- Q05** bianco white
- Q16** seta silk
- Q17** corda ecru
- Q20** ghisa cast-iron
- Q04** nero black

melaminico
melamine
mélaminé
Melamin
melamina

- M03** bianco white
- M02** rovere moka moka oak

agglomerato ligneo
wood composite
aggloméré de bois
holzartiges Agglomerat
aglomerado de madera

20 kg/ml

barre portabiti / clothes rails / barres porte-vêtements / Kleiderstangen / barras perchera

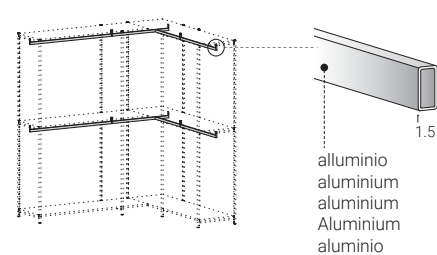

verniciatura a polveri
powder coating
peinture en poudres
Pulverlackierung
pintura en polvo

- C12** bianco white
- C21** seta silk
- C30** ghisa cast-iron
- C08** nero black

alluminio
aluminium
aluminium
Aluminium
aluminio

100 cm => 30 kg



barre portabiti / clothes rails / barres porte-vêtements / Kleiderstangen / barras perchera

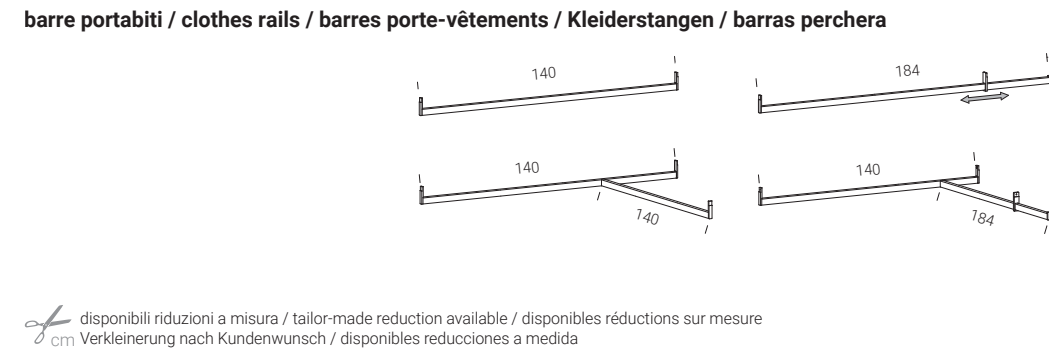

disponibili riduzioni a misura / tailor-made reduction available / disponibles réductions sur mesure
Verkleinerung nach Kundenwunsch / disponibles reducciones a medida

dimensioni / dimensions

ripiani / shelves / étagères / Böden / estantes

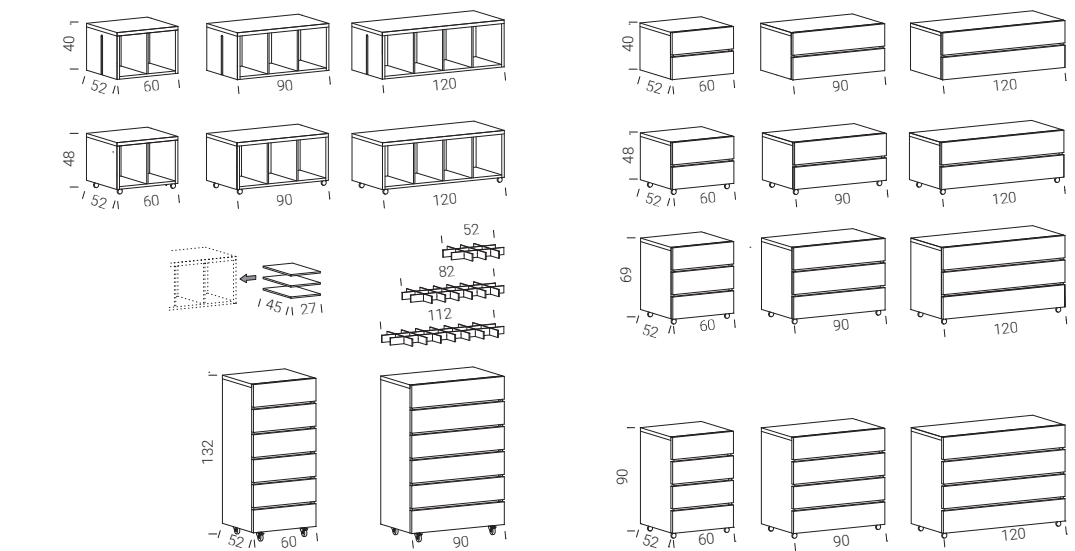

ripiani portascarpe su ruote / shoe rack shelves on casters / étagères porte-chaussures sur roues Böden schuhablage auf rollen / estantes portazapatos con ruedas

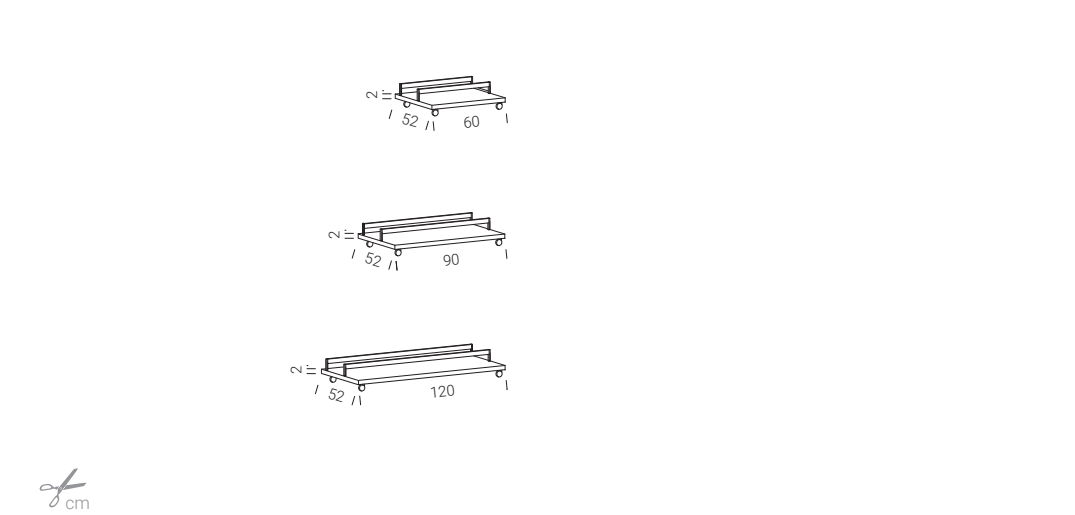

portapantaloni / trouser rail / porte-pantalons / Hosenhalter / portapantalones

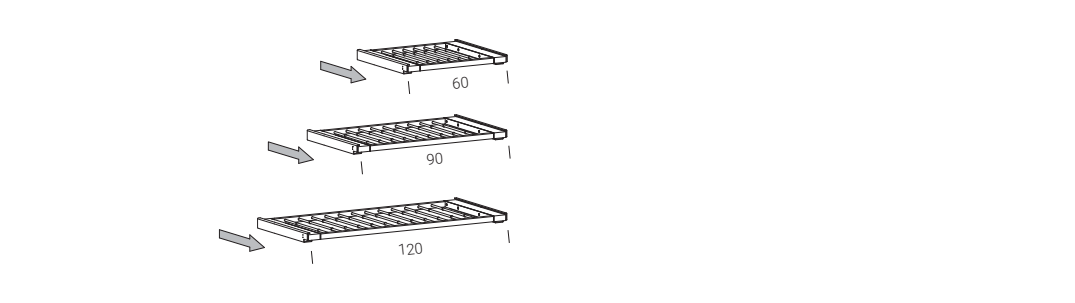



slide
SL01

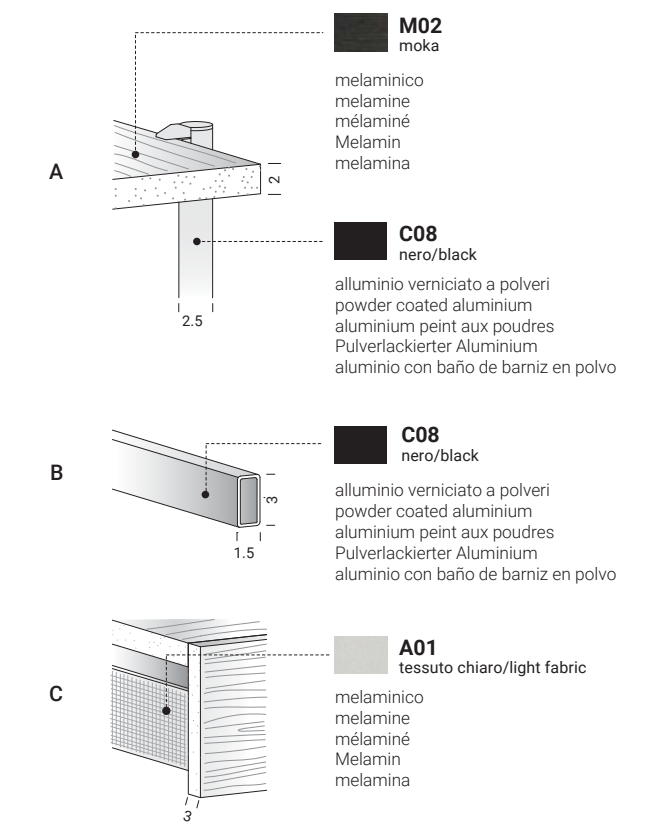
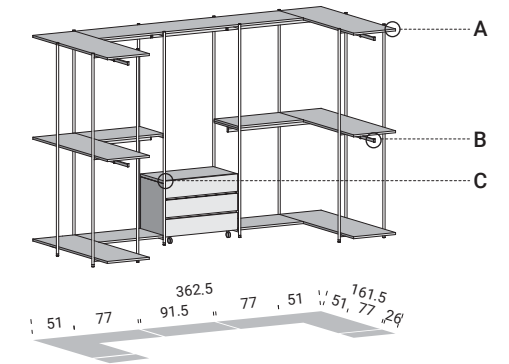

collection info
pg. 290

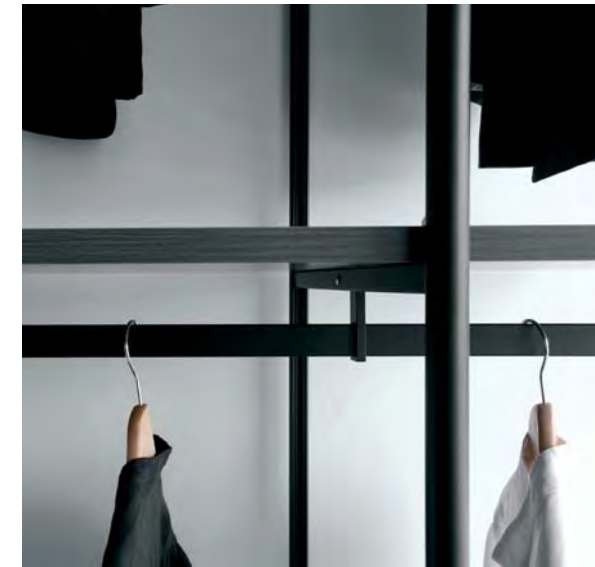



slide
SL04

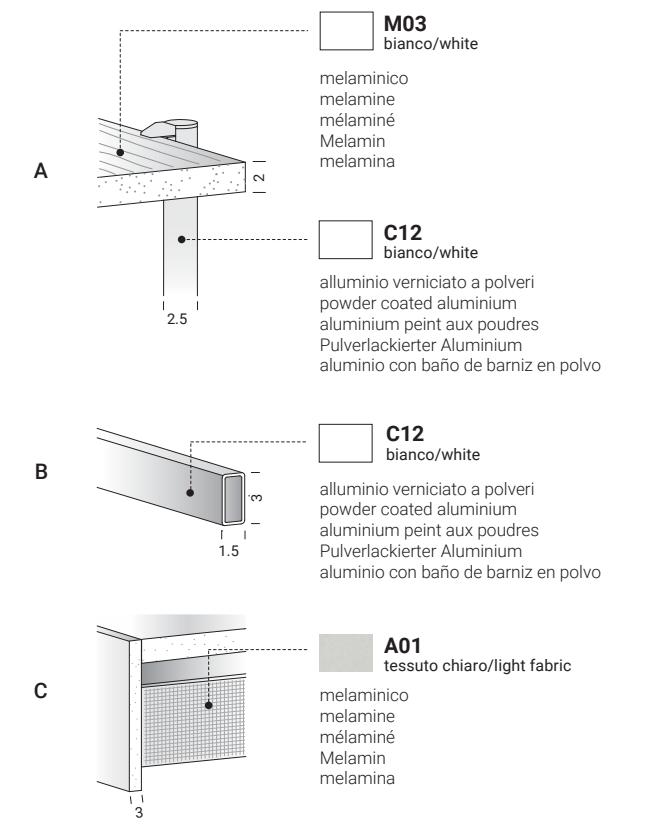
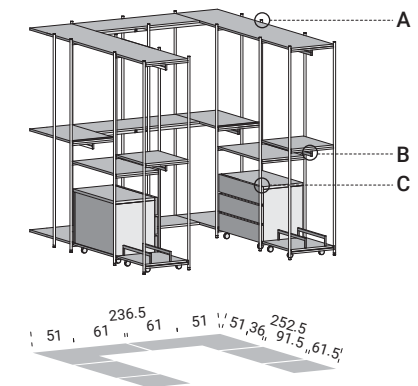

collection info
pg. 290





slide SL03

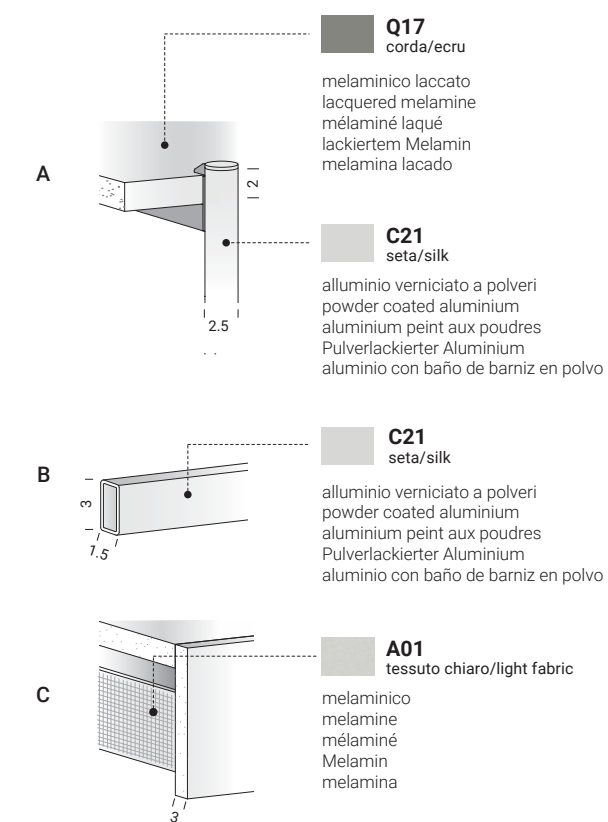
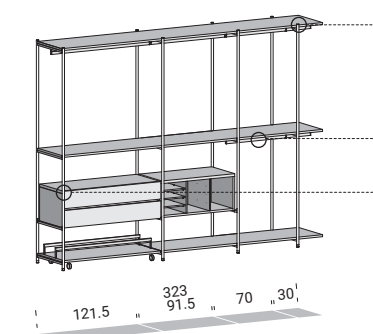

collection info
pg. 290



slide
SL02

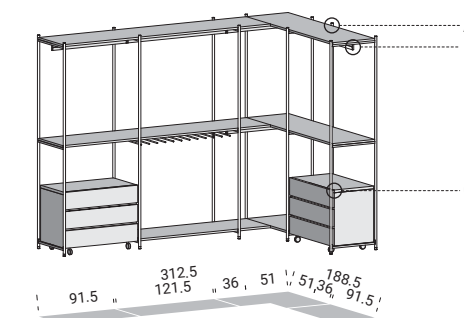

- M03**
bianco/white

melaminico
melamine
mélaminé
Melamin
melamina
- C12**
bianco/white

alluminio verniciato a polveri
powder coated aluminium
aluminium peint aux poudres
Pulverlackierter Aluminium
aluminio con baño de barniz en polvo
- C12**
bianco/white

alluminio verniciato a polveri
powder coated aluminium
aluminium peint aux poudres
Pulverlackierter Aluminium
aluminio con baño de barniz en polvo
- A01**
tessuto chiaro/light fabric

melaminico
melamine
mélaminé
Melamin
melamina

collection info
pg. 290

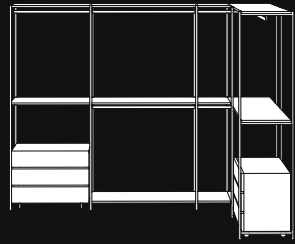

extendo
patented
product

personal

Il sistema brevettato extendo è formato da due profili in alluminio estensibili, adattabili alle diverse altezze degli ambienti. Agendo sulla leva a scomparsa, i profili si bloccano all'altezza desiderata e si comprimono tra pavimento e soffitto, senza l'utilizzo di alcun utensile o pre-fissaggio.

The patented extendo system consists of two extendable aluminium profiles that can be adapted to environments of various heights. Using the foldaway lever, the profiles can be blocked at the desired height and compressed between floor and ceiling, without having to use any kind of pre-fixing tool.

Le système breveté extendo est constitué de deux profilés extensibles en aluminium pouvant être adaptés aux différentes hauteurs des milieux. En agissant sur le levier escamotable, les profilés se verrouillent à la hauteur souhaitée et se compriment entre plancher et plafond, sans utiliser aucun outil ou préfixation.

El sistema patentado extendo está formado por dos perfiles de aluminio extensibles, adaptables a las distintas alturas de los ambientes. Actuando sobre la palanca escondida, los perfiles se bloquean a la altura deseada y se comprimen entre el suelo y el techo, sin que sea necesario utilizar ninguna herramienta o fijación previa.

Das patentierte System extendo besteht aus zwei ausziehbaren Aluminium-Profilen, die an unterschiedliche Raumhöhen angepasst werden können. Durch einen versenkbaren Hebel werden die Profile auf der gewünschten Höhe blockiert und zwischen Fußboden und Zimmerdecke ohne Werkzeug oder Vor-Befestigung komprimiert eingesetzt.



L'asta telescopica extendo esercita una spinta dinamica verso l'alto che consente di assorbire eventuali variazioni d'altezza tra pavimento e soffitto che possono avvenire nel corso del tempo. Per progettare senza vincoli ogni spazio, sono disponibili adattatori soffitto cartongesso, soffitto inclinato e a parete.

The extendo telescopic rod exerts dynamic upward pressure, so that it can absorb any height variations between the floor and ceiling that may occur over time. In order to design any space without limitations, adaptors are available for plasterboard ceilings, sloped ceilings and walls.

La tige télescopique extendo exerce une poussée dynamique vers le haut qui permet d'absorber les éventuelles variations de hauteur entre le plancher et le plafond susceptibles de se présenter au fil du temps. Pour concevoir tout espace sans contraintes, des adaptateurs pour plafond en placoplâtre, plafond incliné et pour application murale sont disponibles.

personal materials



alluminio
aluminium
Aluminium
aluminio

Le materie prime che costituiscono il sistema personal derivano da un processo di riutilizzo e sono a loro volta riciclabili.

The primary materials used in the personal "system" are sourced from a reuse process, and are in turn recyclable.

Les matières premières qui composent le système personal dérivent d'un processus de réutilisation et sont à leur tour recyclables.

Die Rohstoffe für das System personal entstammen einem Wiederverwertungsprozess und sind Ihrerseits wiederum recyclebar.

Las materias primas que constituyen el sistema personal proceden de un proceso de reutilización y son, a su vez, reciclables.



Die Teleskopstange extendo übt einen dynamischen Druck nach oben aus, wodurch mögliche Änderungen des Abstands zwischen Boden und Decke, wie sie im Lauf der Zeit auftreten können, aufgefangen werden. Um jeden Raum ohne Einschränkungen planen zu können, sind Adapter zur Befestigung an Decken aus Gipskarton, Dachschrägen und an Wänden erhältlich.

La barra telescópica extendo ejerce un empuje dinámico hacia arriba que permite absorber las variaciones de altura entre el suelo y el techo que se pueden dar con el tiempo. Para diseñar sin limitaciones cualquier espacio, existen adaptadores de cartón-yeso para techo, techo inclinado y pared.



Profilo extendo con attacco a parete disponibile in tre altezze o con supporto a pavimento autoportante.

Extendo profile with wall coupling available in three heights or with freestanding floor support.

Profilé extendo avec fixation murale disponible en trois hauteurs ou avec support au sol autoportant.

Das extendo Profil mit Wandbefestigung steht in drei verschiedenen Höhen oder mit selbsttragender Bodenhalterung zur Verfügung.

Perfil extendo con sujeción a pared disponible en tres alturas y con soporte autónomo al suelo.

finiture / finishes

extendo

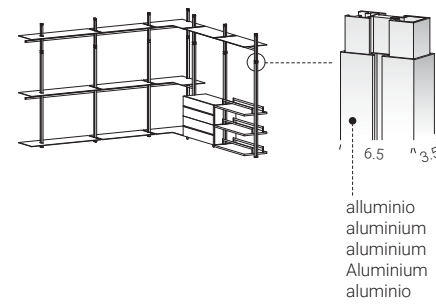

verniciatura a polveri
powder coating
peinture en poudres
Pulverlackierung
pintura en polvo

	C12 bianco white
	C21 seta silk
	C30 ghisa cast-iron
	C08 nero black

alluminio
aluminium
aluminium
Aluminium
aluminio

ripiani / shelves / étagères / Böden / estantes

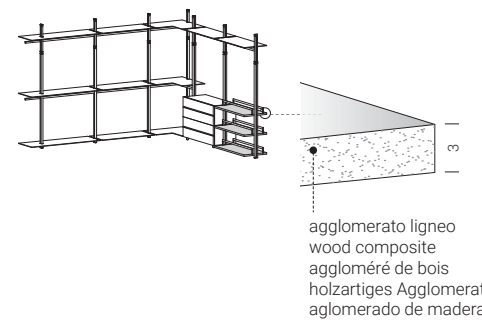

laccato
lacquered
laqué
lackiert
lacado

	Q05 bianco white
	Q16 seta silk
	Q17 corda ecru
	Q20 ghisa cast-iron
	Q04 nero black

melaminico
melamine
mélaminé
Melamin
melamina

	M03 bianco white
	M02 rovere moka moka oak

20 kg/ml

dimensioni / dimensions

extendo

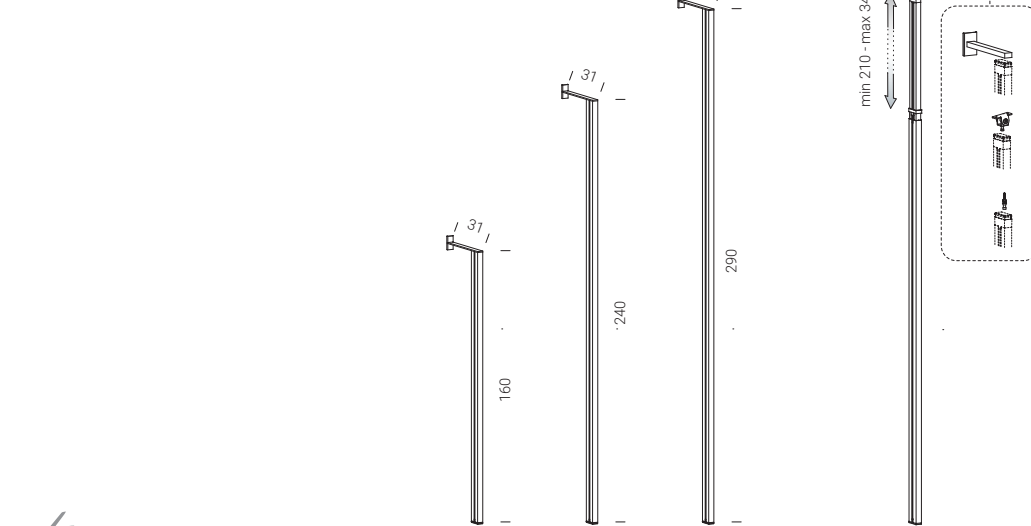

ripiani / shelves / étagères / Böden / estantes

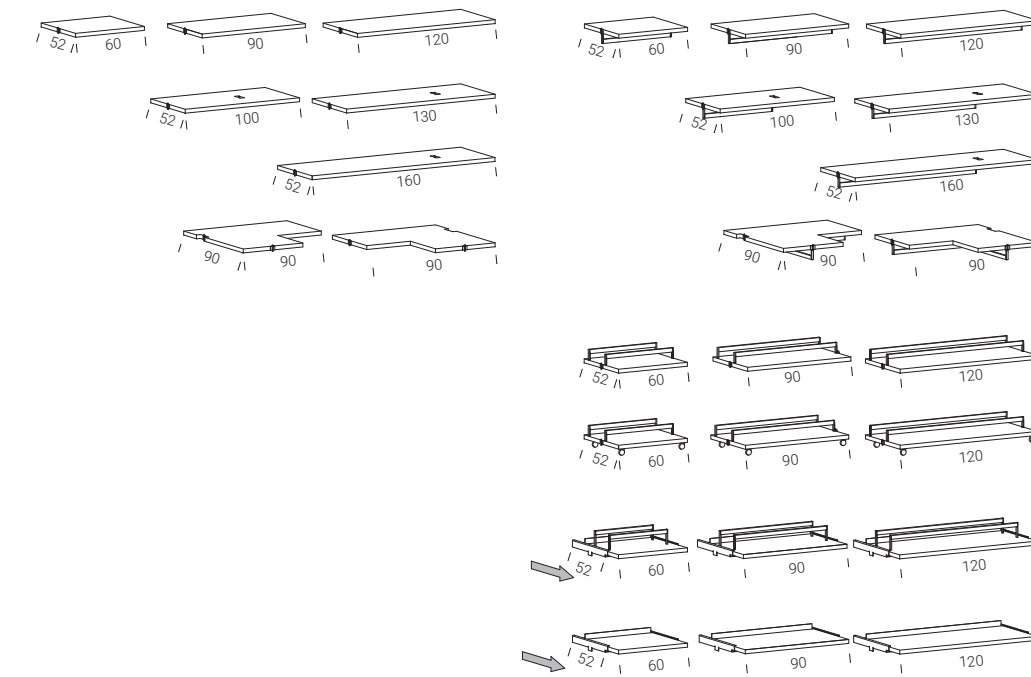

disponibili riduzioni a misura / tailor-made reduction available / disponibles réductions sur mesure
cm Verkleinerung nach Kundenwunsch / disponibles reducciones a medida

finiture / finishes

ripiani / shelves / étagères / Böden / estantes

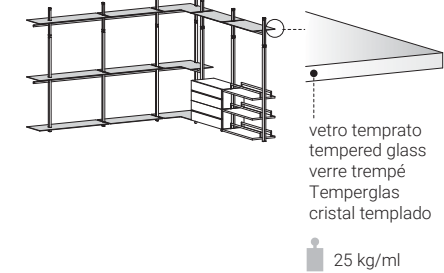

laccato
lacquered
laqué
lackiert
lacado

	V01 bianco white
	V15 seta silk
	V16 corda ecru
	V23 ghisa cast-iron
	V02 nero black

25 kg/ml

	V06 fumè smoked glass
--	------------------------------

contenitori / cabinets / modules de rangement / Behälter / contenedores

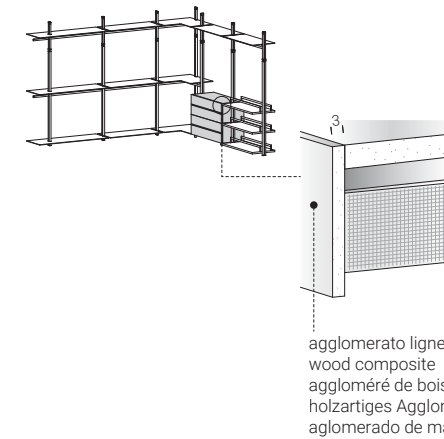

laccato
lacquered
laqué
lackiert
lacado

	Q05 bianco white
	Q16 seta silk
	Q17 corda ecru
	Q20 ghisa cast-iron
	Q04 nero black

melaminico
melamine
mélaminé
Melamin
melamina

	M03 bianco white
	M02 rovere moka moka oak

accessori / accessories / accessoires / Zubehör / accesorios

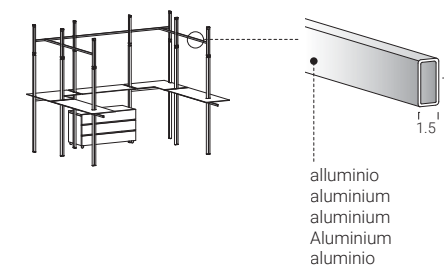

verniciatura a polveri
powder coating
peinture en poudres
Pulverlackierung
pintura en polvo

	C12 bianco white
	C21 seta silk
	C30 ghisa cast-iron
	C08 nero black

alluminio
aluminium
aluminium
Aluminium
aluminio

dimensioni / dimensions

ripiani / shelves / étagères / Böden / estantes

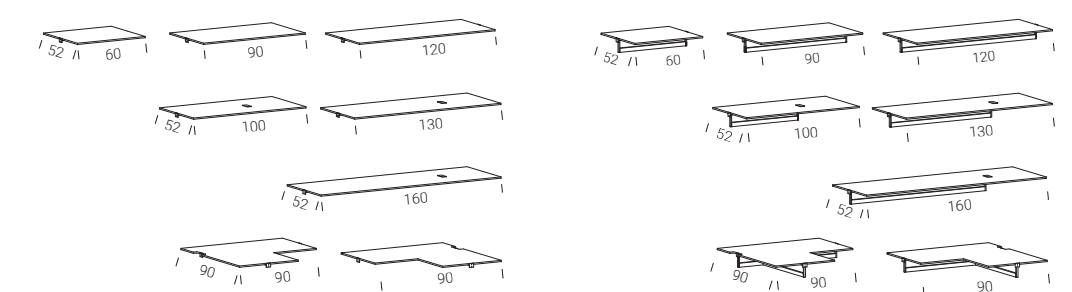

contenitori / cabinets / modules de rangement / Behälter / contenedores

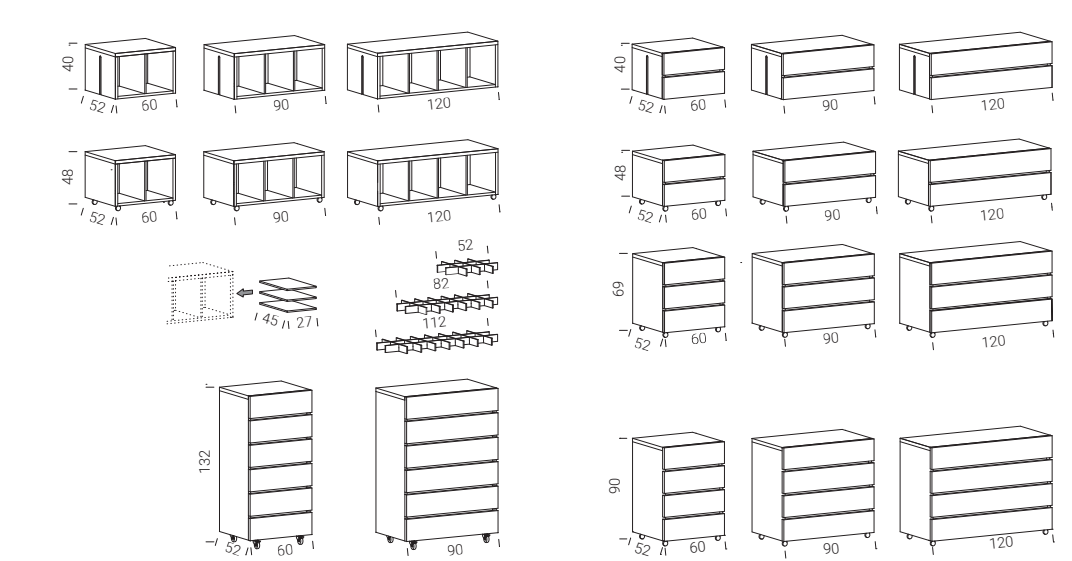

accessori / accessories / accessoires / Zubehör / accesorios

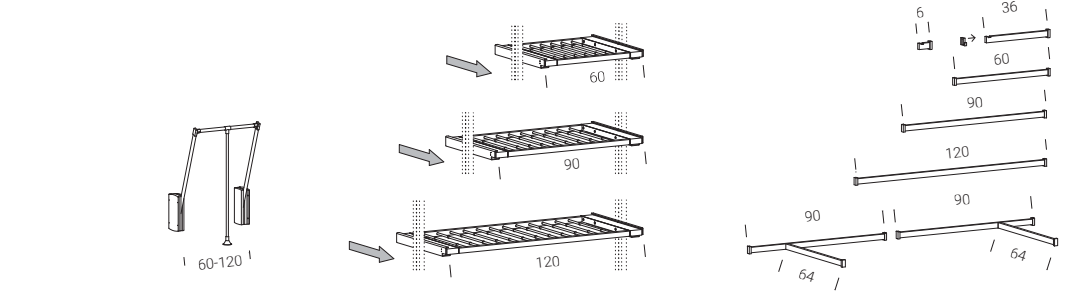



personal
PE01

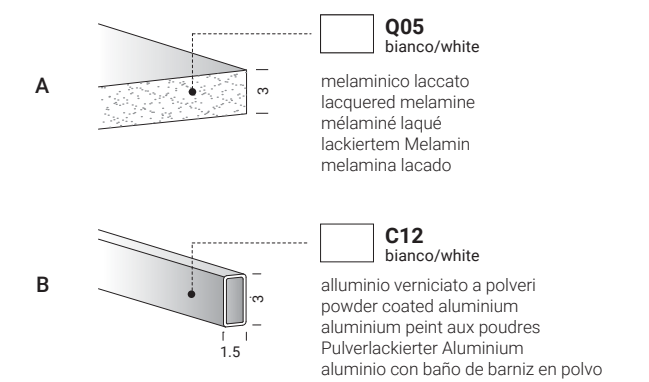
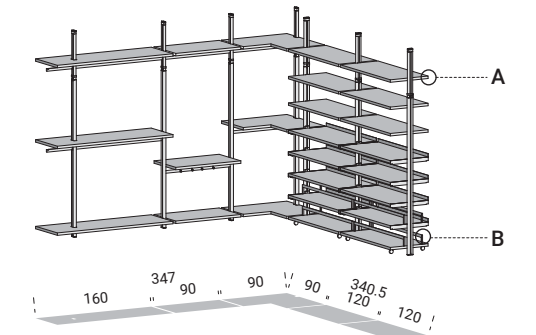

collection info
pg. 306

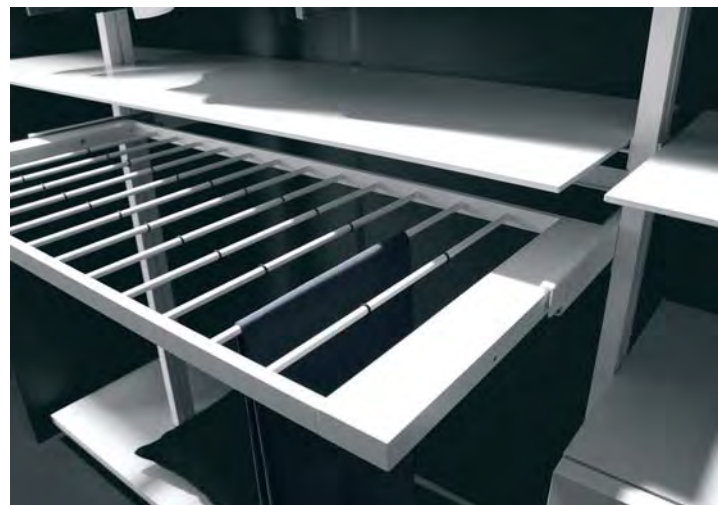

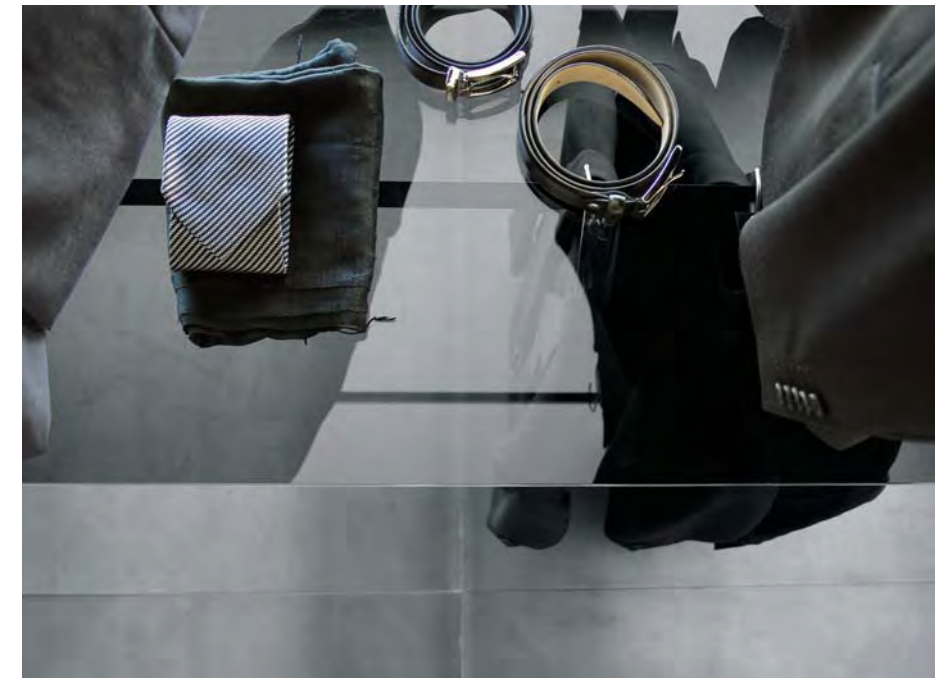

personal
PE02

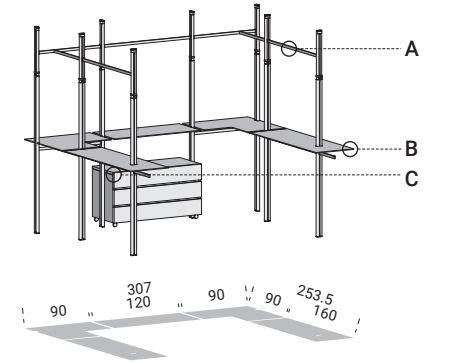

A

C08
nero/black

alluminio verniciato a polveri
powder coated aluminium
aluminium peint aux poudres
Pulverlackierter Aluminium
aluminio con baño de barniz en polvo

B

V06
fumè/smoked glass

vetro temprato
tempered glass
verre trempé
Temperglas
cristal templado

C

Q04
nero/black

melaminico laccato
lacquered melamine
mélaminé laqué
lackiertem Melamin
melamina lacado

A01
tessuto chiaro/light fabric

melaminico
melamine
mélaminé
Melamin
melamina



I ripiani in vetro adottano un esclusivo sistema d'attacco su supporti in alluminio ad incollaggio UV. Il sistema ad incollaggio impedisce ogni contatto diretto con l'asta estensibile. I ripiani in vetro sono disponibili in tutti i moduli della collezione personal, 60/90/120 e ad angolo con o senza barra porta abiti.

The glass shelves have an exclusive mounting system on aluminium supports with UV bonding. The bonding system prevents direct contact with the extendable bar.

The glass shelves are available in all the modules of the personal collection, 60/90/120 and for the corner unit with or without a clothes rail.

Les étagères en verre adoptent un système d'attelage exclusif sur des supports en aluminium à collage UV. Le système à collage empêche tout contact direct avec la tige étirable. Les étagères en verre sont disponibles dans tous les modules de la collection personal, 60/90/120 et à angle avec ou sans barre porte-vêtements.

Die Glasregale haben ein eigenes Befestigungssystem auf Aluminiumhaltern mit UV-Klebung. Das Klebesystem verhindert jeglichen direkten Kontakt mit der ausdehnbaren Stange. Die Glasregale sind in allen Modulen der Personal Kollektion erhältlich, 60/90/120 und mit Winkel, mit oder ohne Kleidungsstange.

Las repisas de vidrio adoptan un sistema de enganche exclusivo en soportes de aluminio mediante encolado UV. El sistema de encolado impide cualquier contacto directo con la barra extensible. Las repisas de vidrio se encuentran disponibles en todos los módulos de la colección personal, 60/90/120 y en ángulo con o sin barra percha para prendas de vestir.

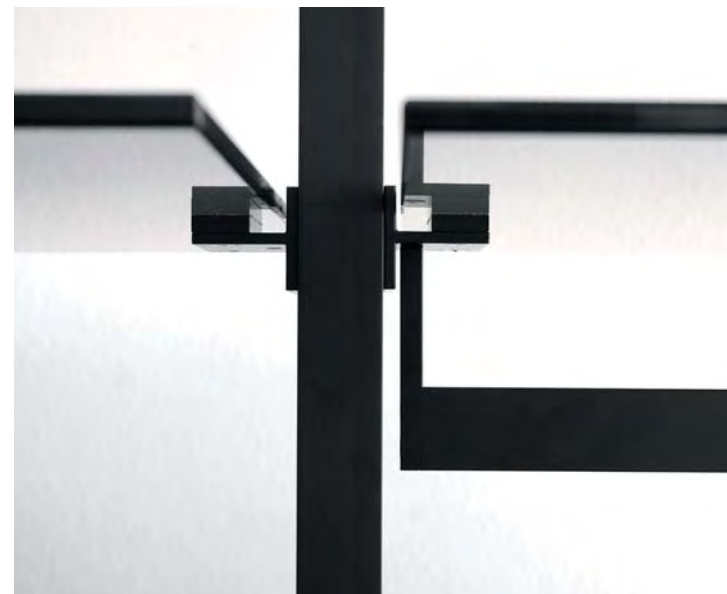



personal
PE03

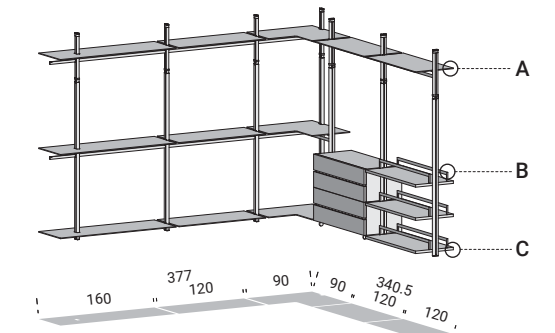

- A**

V01
bianco/white

vetro temprato laccato
lacquered tempered glass
verre trempé laqué
lackiertem Temperglass
cristal templado lacado
- B**

C12
bianco/white

alluminio verniciato a polveri
powder coated aluminium
aluminium peint aux poudres
Pulverlackierter Aluminium
aluminio con baño de barniz en polvo
- C**

Q05
bianco/white

melaminico laccato
lacquered melamine
mélaminé laqué
lackiertem Melamin
melamina lacado

collection info
pg. 306





personal
PE04

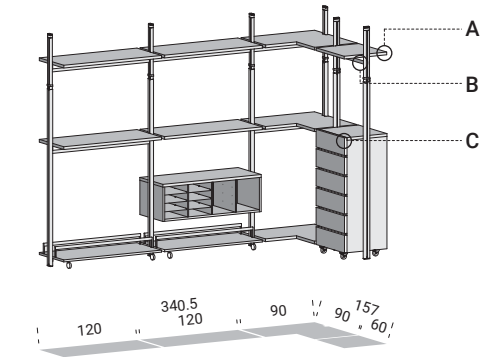

- A**
- Q17**
corda/ecru
melaminico laccato
lacquered melamine
mélaminé laqué
lackiertem Melamin
melamina lacado
- B**
- C21**
seta/silk
alluminio verniciato a polveri
powder coated aluminium
aluminium peint aux poudres
Pulverlackierter Aluminium
aluminio con baño de barniz en polvo
- C**
- A01**
tessuto chiaro/light fabric
melaminico
melamine
mélaminé
Melamin
melamina

collection info
pg. 306



personal
PE05

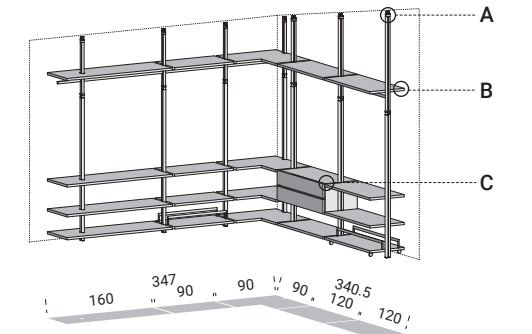

- A**
- C12**
bianco/white
acciaio verniciato a polveri
powder coated steel
acier peint aux poudres
Pulverlackierter Stahl
Acero con baño de barniz en polvo
- B**
- Q05**
bianco/white
melaminico laccato
lacquered melamine
mélaminé laqué
lackiertem Melamin
melamina lacado
- C**
- A01**
tessuto chiaro/light fabric
melaminico
melamine
mélaminé
Melamin
melamina

collection info
pg. 306



personal
PE06

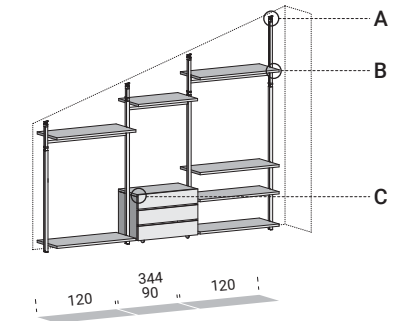

- A**
- C21**
seta/silk
acciaio verniciato a polveri
powder coated steel
acier peint aux poudres
Pulverlackierter Stahl
Acero con baño de barniz en polvo
- B**
- Q17**
corda/ecru
melaminico laccato
lacquered melamine
mélaminé laqué
lackiertem Melamin
melamina lacado
- C**
- A01**
tessuto chiaro/light fabric
melaminico
melamine
mélaminé
Melamin
melamina

collection info
pg. 306



personal
PE07

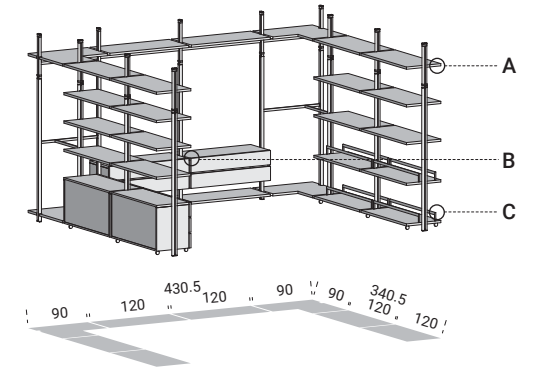

- A**
- Q05**
bianco/white
melaminico laccato
lacquered melamine
mélaminé laqué
lackiertem Melamin
melamina lacado
- B**
- A01**
tessuto chiaro/light fabric
melaminico
melamine
mélaminé
Melamin
melamina
- C**
- C12**
bianco/white
alluminio verniciato a polveri
powder coated aluminium
aluminium peint aux poudres
Pulverlackierter Aluminium
aluminio con baño de barniz en polvo

collection info
pg. 306



Le barre porta abiti in alluminio sono disponibili in tutti i moduli della collezione personal, 60/90/120 e ad angolo, agganciate al ripiano o direttamente al profilo estensibile, finitura C04 alluminio silver.

The aluminium clothes rails are available for all the modules of the personal collection, 60/90/120 and corner unit, hooked to the shelf or directly to the extendable profile, with a silver C04 aluminium finish.

Les barres porte-vêtements en aluminium sont disponibles dans tous les modules de la collection personal, 60/90/120 et à angle, accrochées soit à l'étagère soit directement au profil étirable, finition C04 aluminium silver.

Die Kleidungsstangen aus Aluminium sind in allen Modulen der Personal Kollektion erhältlich, 60/90/120 und mit Winkel, die am Regalbrett angebracht sind, oder direkt am ausdehnbaren Profil, in Silber-Aluminium C04 Endbearbeitung.

Las perchas para prendas de vestir de aluminio se encuentran disponibles en todos los módulos de la colección personal, 60/90/120 y en ángulo, enganchadas en la repisa o directamente en el perfil extensible, con acabado C04 aluminio silver.



personal
PE08

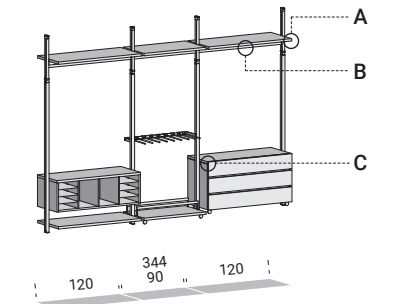

- A**

M02
moka

melaminico laccato
lacquered melamine
mélaminé laqué
lackiertem Melamin
melamina lacado
- B**

C21
seta/silk

alluminio verniciato a polveri
powder coated aluminium
aluminium peint aux poudres
Pulverlackierter Aluminium
aluminio con baño de barniz en polvo
- C**

A01
tessuto chiaro/light fabric

melaminico
melamine
mélaminé
Melamin
melamina

collection info
pg. 306



personal
PE09

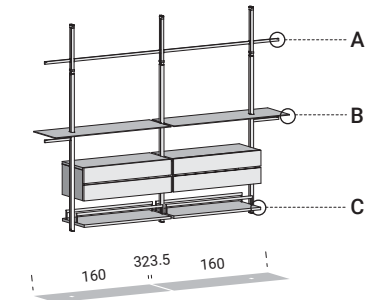

- A**
- C12**
bianco/white
- alluminio verniciato a polveri
powder coated aluminium
aluminium peint aux poudres
Pulverlackierter Aluminium
aluminio con baño de barniz en polvo
- B**
- V01**
bianco/white
- vetro temprato laccato
lacquered tempered glass
verre trempé laqué
lackiertem Temperglas
cristal templado lacado
- C**
- Q05**
bianco/white
- melaminico laccato
lacquered melamine
mélaminé laqué
lackiertem Melamin
melamina lacado

collection info
pg. 306

art direction
extendo design dept.

photo post-production
extendo design dept.
marigraf.it

graphic layout
marigraf.it

EXTENDO
DESIGN SOURCE

via Del Lavoro 2
35010 Trebaseleghe PD - Italy

tel. +39 049 9387633
fax +39 049 9387644

www.extendoweb.com
info@extendoweb.com



extendo ©
ESTV0079