

Home Decorative
Storage System

LT40



LT40

Home Decorative
Storage System

LT40

LEIVA



INDEX

1. Introduction — 6
2. The families — 8
3. Compositions — 12
 - Living Rooms — 14
 - Dining Rooms — 40
 - Kitchens — 70
 - Home Offices — 78
 - Passage Spaces — 96
 - Bedrooms — 112
 - Walk-in Closet — 128
4. Assemblages — 84
 - Technical Index — 142
5. Technical Sheet — 144
6. Samples Collection — 170



1.

INTRODUCTION

Il sistema LT40 di Lema è la sintesi della filosofia progettuale dell'architetto madrileno David López Quincoces, improntata alla purezza delle linee di uno stile senza tempo. È un sistema di contenitori, di pensili, madie, boiserie caratterizzati dalla forte personalizzazione.

L'eleganza è fatta di tanti dettagli diversi, alcuni saltano subito allo sguardo, altri si celano e la loro scoperta implica un impegno gentile, un approccio alla conoscenza, quasi uno studio che conduce all'apprezzamento fino all'ammirazione. Si presenta così il nuovo sistema LT40 di Lema: elegante nella sua silenziosa raffinatezza, privo di fronzoli, dal forte impatto visivo e ricco di una molteplicità di dettagli da renderlo quasi un'architettura versatile ideale per ogni ambito della casa. E per questo, ammirabile. LT40 è la sintesi della filosofia progettuale di David López Quincoces, architetto madrileno, noto per la sua vocazione alla purezza delle linee e allo stile senza tempo. Quello che elimina le banalità e favorisce lo studio concettuale e lo sviluppo industriale di un progetto come quello di LT40: un sistema di contenitori e di elementi a parete, ovvero di madie, pensili e boiserie caratterizzati da una fondamentale specificità quella di essere fortemente personalizzabili.

Elegance is achieved by different details. Some catch the eye immediately. Others are concealed, and their discovery requires effort, an attempt to get to know them, a study leading to appreciation and at times admiration. This is the description of the new LT40 system by Lema. Its elegance is given by refinement devoid of fussiness, distinguished visual presence and richness of detail, making it a versatile type of architecture ideal for every room of the house. That's admirable. LT40 is the synthesis of the design philosophy of the Madrid architect David López Quincoces. Known for the pureness of his lines and his timeless style, he eliminates the commonplace, conducts conceptual studies, and develops industrial projects such as the LT40 – a modular family of cabinets and wall elements: shelves, sideboards, cabinets and panelling characterised by the fundamental specificity of being highly customisable.

LT40 embodies the design philosophy of Madrid architect David López Quincoces. Characterised by pure lines of timeless style, this furniture system is composed of shelves, cabinets, sideboards and panelling, designed to be mixed and matched.

2.

THE FAMILIES

Madie, pensili, mensole, panche. E ancora, contenitori bifrontali, boiserie, cornici. Ogni elemento ha la sua specificità estetica ma una molteplice versatilità d'uso che permette varie combinazioni ad alto tasso di personalizzazione. È ricca, poliedrica, multifunzionale e sorprendente la famiglia del sistema LT40. Qui, proposte in svariate declinazioni possibili.

Examples



01.



02.



03.

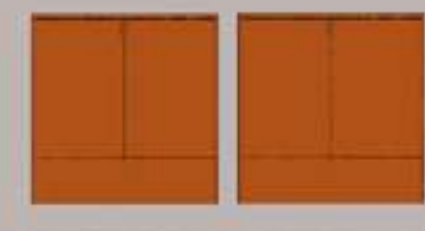

04.



05.



06.



07.



08.



09.

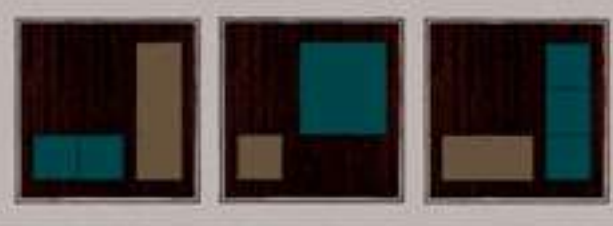

10.



11.



12.



13.



14.



15.

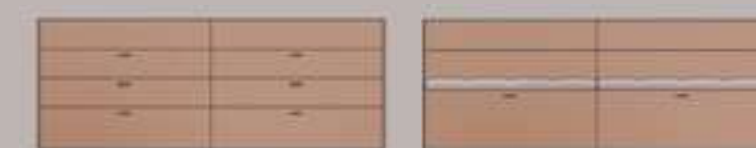

16.

Cabinets, cupboards, shelves, benches, double-access elements, wood panelling and framed units: each with its own aesthetic specificity, and each with the versatility of multiple uses. LT40 allows for infinite combinations. Customisation possibilities are endless. The family of elements is rich, eclectic, multifunctional and new. Here proposed in multiple different solutions.



3. COMPOSITIONS

Comporre e scomporre le quattro famiglie che costituiscono il sistema LT40 per reinterpretare, ogni volta in maniera diversa, un modo di arredare contemporaneo e cosmopolita.

Compose and rearrange the four LT40 families in different ways. Interpret contemporary furnishing trends and new cosmopolitan styles.

Ideare e creare in un gioco di composizioni e scomposizioni.

La creatività sta nell'infinita possibilità di accostare elementi diversi e dialoganti tra loro in base alle proprie esigenze e sensibilità. Lucidi, opachi, finiture artigianali, dettagli sartoriali, elementi hi-tech, tutto si può mixare perché questa è la filosofia del sistema LT40 di Lema. Un sistema di contenitori a parete che si snoda in quattro configurazioni principali: a terra, leggermente sollevate (madie), sospese (pensili) e integrate con la parete (boiserie). Quattro famiglie che costituiscono la speciale architettura di un modo di arredare contemporaneo, armonico e dal gusto internazionale.

Have fun conceiving and creating compositions with the elements of LT40. Creativity is given by the infinite possibilities of arranging different families of elements based on your needs and taste. Glossy, matt, hand-crafted finishes, bespoke details and high-tech elements can all be mixed, this is the basis of the LT40 system by Lema. The wall cabinets come in four main configurations: standing; slightly elevated from the floor (sideboards); wall-hung (cupboards) and integrated in the wall panelling. The four types constitute the architectural backbone of a contemporary way to furnish rooms with harmony and contemporary style.

LIVING ROOMS

Il living, prospettiva larga e scenografica, luogo delle possibilità di scambio tra i componenti della famiglia e teatro dell'ospitalità vera e premurosa. Lampade che giocano con le ombre, divani che abbracciano corpi, tavolini che ospitano libri, contenitori che custodiscono oggetti utili, ricordi di viaggi, tecnologia quotidiana per momenti ludici. È questo lo spazio del relax, dell'intimità e della socialità, della riflessione e del gioco.

The broad, scenographic perspective given by the living room is where the family spends time together, friends are welcomed, and visitors are treated to true, considerate hospitality. Here, lamps play with shadows, sofas give comfort to guests, coffee tables display books, and furniture contains useful objects, travel souvenirs and the everyday tech devices of entertainment. The living room is for relaxation, conversation, sociability, thinking and playing.





Divano, Sofa **Cloud**
Tavolino, Coffee Table **Flowers**

Tavolo, Table **Luce**
Poltroncina, Armchair **Hati**

Come in un altorilievo,
il contenitore pensile,
dal prospetto asimmetrico,
è affiancato dalla sofisticata
boiserie W-Line in legno,
impreziosito da una grafica
millerighe tridimensionale,
frutto di una complessa
lavorazione artigianale.
A sostenere l'architettura
agile e d'impatto, una panca
sospesa generosa con due
cassetti multifunzione.

Like a high relief, an
asymmetrically fronted
cabinet juts out against the
background of the refined
W-Line wood panelling
whose three-dimensional
pinstripe texture is the fruit
of meticulous craftsmanship.
Forming a base to this agile
and striking architectural
presence is a generous shelf
with two multifunctional
drawers.





Cassetti svuota tasche della stessa dimensione interrompono la scansione lineare della panca attribuendole un sussulto di colore. Lo stesso delle ante dei contenitori, impreziosite da maniglie in finitura bronzo.

Tray-like drawers, both the same size, break the linear arrangement of the bench and give it a pop of colour. The same role is played by the cabinet doors, embellished by bronze-plated handles.





Divano, Sofa **Snap**
Tavolino, Coffee Table **Cruise**

Tavolino, Coffee Table **Sign**

Sempre più ampia la possibilità di mixare i sistemi di apertura degli elementi contenitori LT40. I pensili in noce-L con apertura push&pull esaltano la pulizia delle linee. E' armonico il contrasto materico e cromatico tra laccato lucido del mobile e laccato opaco di base e maniglie in metallo.

The possibility of mixing the opening systems of the LT40 container elements is wider. The wall units in L-walnut with push & pull opening enhance the clean lines. The material and chromatic contrast between the glossy lacquer of the cabinet and the matt lacquer for base and metal handles, is harmonious.





A sinistra, dettaglio dei pensili in noce-L con apertura push&pull e della cassetiera in laccato lucido color persia con maniglia tono su tono in versione opaca. A destra, l'anta a ribalta svela il dettaglio del vano multimediale. Il top è dotato di elemento passacavi per la tv, e all'interno del vano è alloggiato il ripetitore di segnale per gestire gli apparecchi tecnologici quando l'anta è chiusa.

On the left, detail of the wall units in L-walnut with push & pull opening and of the chest of drawers in persia glossy lacquer with tone-on-tone handle in the matt version. On the right, the flap door reveals the detail of the multimedia compartment. The top is equipped with a cable outlet for the TV, and the IR system is placed inside the compartment to manage the technological devices when the door is closed.



Divano, Sofa **Jermyn**
Poltrona, Armchair **Alton**
Tavolino, Coffee Table **Mr Zheng**

Legno, colore, luce, trasparenze, asimmetrie e geometrie: LT Frame è un sistema nel sistema che alleggerisce i volumi pieni dei contenitori e delle madie e interrompe il rigore lineare delle composizioni. LT Frame vanta 12 cornici di due diverse tipologie dimensionali da appendere alla parete come inediti quadri resi ancora più affascinanti dalla luce dei Led che ne esalta tutto il perimetro interno.

Wood, colour, light, transparency, asymmetry and geometry are the ingredients of the LT Frame, a system inside the system. Frames lighten the closed solids of the cabinets and sideboards, breaking the composition's linear severity. The LT Frame comes in 12 frames of 2 different sizes. Wall-hung, they form unusual paintings made even more attractive by Led that light up the entire inside perimeter.





L'anta a ribalta con maniglia in finitura bronzo nasconde l'alloggiamento di oggetti oppure, in alternativa, il cablaggio degli accessori tecnologici.

A drop-front panel is pulled down by a bronze-plated handle, opening a compartment for objects. Alternatively, it can contain the cables of technological accessories.



Day Bed, Yard
Tavolino, Coffee Table Mr Zheng

Il top, in regale marmo nero portoro dalle preziose venature dorate, dialoga a livello cromatico con la laccatura lucida miele dei mobili sospesi: ampi contenitori con mensole, corredati da ante battenti e ante a ribalta. Per un effetto che trasmette valore.

A top in regal portoro marble precisely veined with gold finds a chromatic match in the shiny lacquered miele colour of the wall-hung cabinets, whose generous space is divided by shelves and contained by hinged doors and drop-front panels. The overall effect is one of distinction.





Piacevole al tatto e preziosa allo sguardo la maniglia in finitura di bronzo realizzata su progetto di David López Quincoces, autore di tutto il sistema LT40. Non meno importanti i ripiani in vetro extra light che acquistano lucentezza con l'illuminazione interna applicata al top. Quest'ultimo, nella versione più elegante, è in marmo portoro, un marmo italiano, storicamente amato da principi e imperatori.

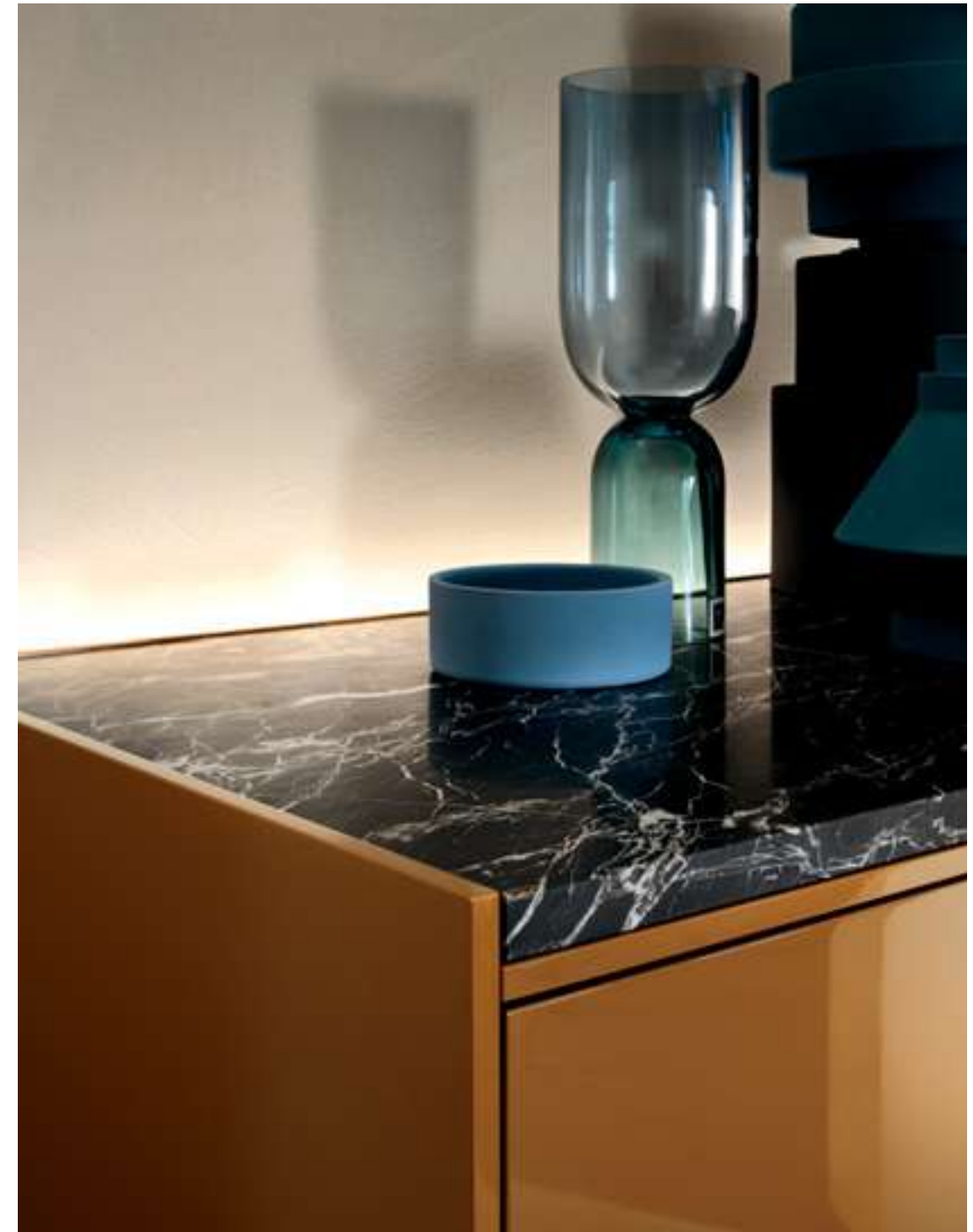

Pleasant to the touch and pleasing to the eye, the bronze-finish handles were designed by David López Quincoces, who conceived the entire LT40 system. Shelves of extra-light glass acquire shine from internal lighting projected down from the top, the most elegant version of which is crafted in portoro marble quarried in Italy, historically favoured by royalty and emperors.

DINING ROOMS

Il dining, ovvero la sala da pranzo, il luogo che in una casa, classicamente, riscrive le regole della convivialità domestica, aggiornandole secondo i tempi e le mode ma senza mai sconvolgerne l'essenza: la condivisione del racconto che accompagna quella del cibo. È un'operazione catartica che nutre ricordi, racconti oltre che corpi. Per questo il contesto è importante: l'armonia di linee e colori, di superfici e volumi concilia l'intimità della condivisione.

Classically, the dining room is where the rituals of conviviality are established and updated in accordance with the times. As we know, their essence always remains the same, namely sharing conversation over food. Such cathartic togetherness nourishes our bodies and our memories. To promote story-telling, the context is important. Harmony of lines, colours, surfaces and volumes facilitates the intimacy of sharing.





Tavolo, Table Gullwing
Sedia, Chair Lucylle
Pouf Pouf

Equilibrisi di figure geometriche e forti contrasti visivi. LT40, con le sue forme decise e minimali, crea un'atmosfera di elegante simmetria. Caratterizzato dai suoi volumi monolitici, il sistema LT40 assorbe le misure dello spazio al quale è destinato, per ospitare e custodire gli oggetti del living.

Equilibrium of geometric figures and strong visual contrasts. LT40, with its strong and minimal shapes, creates an atmosphere of elegant symmetry. Characterized by its monolithic volumes, the LT40 system absorbs the measurements of the space for which it is intended, to host and store the objects of the living room.





Dettaglio dell'anta battente con apertura push&pull, che svela il vano interno illuminato e il ripiano in vetro trasparente extralight.

Detail of the hinged door with push & pull opening, which reveals the illuminated internal compartment and the transparent extralight glass shelf.



Come specchi che amplificano luce e spazi, le ante laccate lucide di LT40, accostate a superfici opache e in noce-L, esaltano la forte matericità per un risultato sofisticato e fuori dagli schemi.

Like mirrors that amplify light and spaces, the glossy lacquered doors of LT40, combined with matt surfaces and in L-walnut, enhance the strong materiality for a sophisticated and unconventional result.





Tavolo, Table Alamo
Sedia, Chair Ombra

In un gioco di lucidi e opachi, in un'alternanza di volumi vuoti e pieni, la madia combina le specchianti ante laccate con il top e con il vano a giorno, entrambi realizzati in noce L, particolare finitura del noce canaletto, studiata da Lema. A completare l'armonia un pomolo in metallo, discreto nella sua utilità d'uso. Il connubio è perfetto e regala un fascino di sobria eleganza.

The sideboard features a juxtaposition of matt and glossy, alternating solids and voids. It is a combination of mirror-shine lacquered doors with wood for the top and open compartments. Noce L is a particular finish of black walnut developed by Lema. The harmony is completed by a discreet metal knob, the perfect useful detail to impart sobriety and elegance.





La finitura in noce così curata implica un contatto: la mano poggia gli oggetti e accarezza la superficie. Importante, il dettaglio del top vassoio, un ulteriore riguardo alla raffinatezza del sistema LT40.

The walnut wood is treated in such a way as to invite contact. As the hand places an object on it, the surface asks to be caressed. An important detail is the top's tray-like edging, another mark of refinement in the LT40 furniture.

Nella sua vocazione trasformativa, LT40 propone una fuga orizzontale di mobili sospesi che interrompono la loro linearità grazie all'inserimento di un vano a giorno, in contrasto per colore e volume. È qui che libri, mini sculture, vasi possono essere riposti e mostrati, mentre dietro le ante si nascondono suppellettili, piatti, bicchieri, vassoi, di uso quotidiano, tipici della sala da pranzo.

In its transformative spirit, LT40 proposes a horizontal flight of wall-hung furniture whose linearity is broken by the insertion of an open compartment contrasting in colour and volume. This is where books, small sculptures and vases can have their place and be displayed, while concealed behind the cabinet doors are the dishes, plates, glasses and trays for daily use, the objects typical of dining rooms.





L'anta a ribalta si avvale di un sistema d'apertura costituito da un cavetto in nylon colore grigio contenuto in un carter talmente piccolo da essere quasi invisibile.



The drop-front panel uses an opening system made up of a grey nylon wire contained in a case so small as to be almost invisible.

A rendere ancora più scenografica la composizione, la luce a Led che corre lungo il perimetro superiore e, volendo, inferiore. Una serie combinata di telai in alluminio, posizionati tra il mobile e la parete, consente l'inserimento della luce Led. Così da ricreare una speciale atmosfera e da promuovere giochi di ombre con gli oggetti sul top.

Making the composition even more scenographic is a Led light strip running all along the back of the top and as an option, all underneath. Aluminium frames positioned between the cabinet and the wall give lodging to the Led, creating a special atmosphere and a playing a game of shadows with the objects standing on top.





Tavolo, Table **Graceland**
Poltroncina, Armchair **Bea**
Pouf **Notch**

I colori della terra, dal marrone al grigio, all'antracite, caratterizzano la composizione realizzata da boiserie, pensile, panca in marmo ricostruito belgianblue e vano a giorno in vetro temperato. Sporgenze e rientranze, superfici lucide e trasparenti, legni preziosi abbinati a elementi materici rappresentano una sofisticata scelta di elementi per una inconsueta narrazione del dining.

Earthy colours ranging from brown and grey to anthracite characterise this composition made up of panelling, cupboards, bench in belgianblue reconstructed marble, and open glass compartments. Recessed and projecting parts, shiny and transparent surfaces, and precious types of wood combined with textural elements all make for a sophisticated choice of elements for an extraordinary setting for dining.





Tavolo, Table **Bulè**
Poltroncina, Armchair **Bea**



La panca qui mostrata è realizzata in argilla ardesia e rappresenta una finitura alternativa a quella in marmo ricostruito belgianblue. Sempre all'insegna della personalizzazione.

Here, the bench is made in ardesia clay, an alternative material to the belgianblue reconstructed marble, always with customisation in mind.





KITCHENS

Luogo del fare e del gustare
Cooking, eating and socialising

La cucina è il fulcro,
lo spazio centrale della
casa dove ogni gesto è
reiterato e diventa rituale
di convivialità e creatività
del saper fare.

The kitchen is the hub
of the home, where
repeated rituals create
conviviality, and the
creativity of know-how
flourishes.



La magia di emozionare attraverso il colore: il rosso paprika di Lema. Una nuance calda, corposa, materica che dà valore aggiunto all'elegante madia posta su una base in finitura bronzo patinato, regolabile in altezza. Perfetta la simmetria dei quattro quadrati disegnati dalle ante impreziosite dalle maniglie in bronzo.

The magic of emotions is found in the colour paprika by Lema, a warm, rich, full-bodied shade of red that gives a punch of panache to the elegant cupboard perched on a metal structure whose height-adjustable feet are finished with a bronze patina. Four perfect squares form the symmetrical doors, embellished with bronze handles.





La struttura della madia, e di tutti i contenitori del sistema LT40, ovvero i fianchi e, volendo, i ripiani, è realizzata in un materiale innovativo chiamato greyvelvet per via del suo colore grigio intenso e per essere vellutato al tatto. Una specificità di Lema, sempre tesa alla ricercatezza così come la cerniera ridotta, come misure, ai minimi termini.



The structure of the cupboard – and of all LT40 cabinets – is finished with an innovative coating called greyvelvet for its intense grey colour and velvety feel. The sides of the furniture (and optionally, the shelves) are soft to the touch, a signature trait at Lema, always on the look-out for refined details such as robust hinges that are as small as possible.

HOME OFFICES

In forma di ufficio. Non le fisicità classiche di una maxi scrivania, di una poltrona in pelle e di una libreria massiccia, ma forme leggere aventi la stessa funzione: quella di conciliare il lavoro, di promuovere la concentrazione, di rendere produttivo ed efficiente il tempo. L'ufficio in casa è un segno della contemporaneità, un'interpretazione del mondo che cambia.

The form of the office is no longer maxi desks, high-backed leather armchairs and massive bookcases, but lighter furniture having the same function, namely to facilitate work, promote concentration, and make your time productive and efficient. The home office is a sign of contemporaneity, an interpretation of our changing world.



La fragranza lignea della boiserie in noce-L fa da piacevole sfondo e sostegno al piano scrittoio sospeso. Fondamentali i due capienti cassetti, custodi di dossier e appunti di lavoro, oltre che di tecnologie da office. Sdrammatizzano e regalano un tocco di luce gli elementi sospesi in vetro temperato trasparente extralight con schienale in contrasto laccato opaco.

The fine scent of wood panelling in L-walnut forms a pleasant backdrop for the suspended writing desk. Fundamental elements are two spacious drawers to keep folders, memos and office technology. Wall-hung cubes of extra-light tempered glass soften the seriousness and give the setting a touch of light. Their back panels are matt lacquered for contrast.



Poltroncina, Armchair **Babi**



Discreti e funzionali i contenitori multimediali, dotati di un'attrezzatura interna perfetta per installare apparecchi tecnologici. Studiata è la ventilazione così come l'ordine nel passaggio dei cablaggi, l'accesso alle prese e alle derivazioni. Facile, inoltre, l'ispezionabilità dei collegamenti.

Discreet, functional elements for multimedia devices have perfectly appointed interiors for the installation of tech units. Ventilation, orderly cable storage, access to electric outlets and extension cords, and easy inspection of connections: all has been resolved.



4.

ASSEMBLAGES

Il dialogo tra forma e materiali sta al piacere tattile come la cura certosina dei dettagli sta all'eleganza firmata Lema.

Legni, marmi, metalli. Rovere carbone, noce-L, argilla ardesia. E ancora cristallo, bronzo, greyvelvet. Un inventario di materiali la cui fisicità affascina la creatività, promuove accostamenti e diversità. L'assemblage di Lema è un'operazione di ricerca inclusiva che tende a sintetizzare l'eleganza con un effetto estetico mai scontato. Osare inediti accostamenti di materie prime per sperimentare nuove manufatti secondo un'idea di progetto frutto della filosofia di Lema.

Wood, marble and metal have special Lema finishes called carbone oak, L-walnut, ardesia clay and greyvelvet – all are combined with glass and bronze. The inventory of materials was carefully selected to fascinate the creative eye, to promote interesting combinations of diverse textures. Combinatory studies are an all-round line of research at Lema, aimed at encapsulating elegance with a novel aesthetic effect. The audacious juxtaposition of different raw materials goes hand in hand with experimentation in new types of manufacturing along the lines of the design thinking at Lema.

At Lema, the dialogue between shapes and materials is an indispensable part of tactile pleasure. Just as meticulously crafted details are an active ingredient of elegance.



Assemblage 1+2



Rovere carbone
Carbone oak



LCL Miele 239

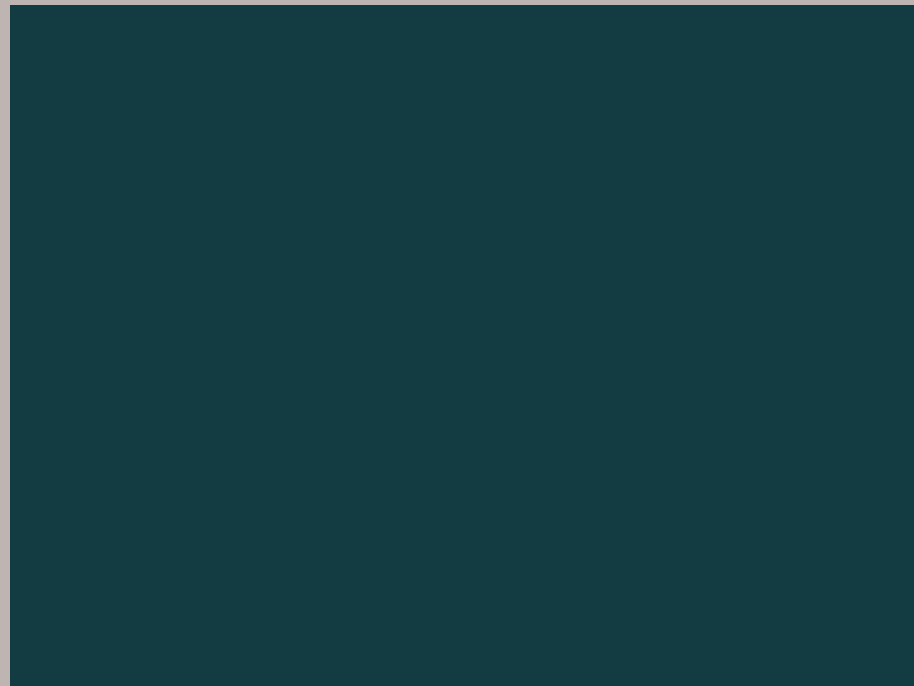

LCT Petrolio 846



LCL Granata 238



W-line



Argilla ardesia
Ardesia clay

Assemblage 1+2



Argilla creta
Creta clay



Melaminico stone
Stone melamine



LCT Paprika 826



Metallo verniciato bronzo patinato M422
Patinated bronze painted metal M422



Marmo portoro
Portoro marble



LCT Terracotta 478



Assemblage 3+4



LCL Grigio 205

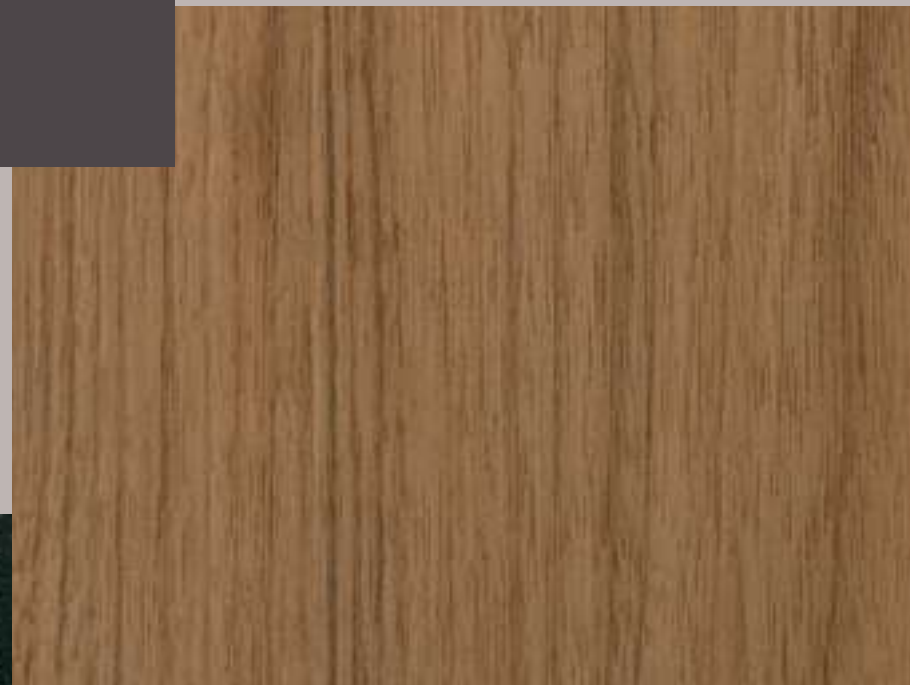

Noce-L
L-walnut



Marmo ricostruito, Verde malachite
Reconstructed marble, Malachite green



Marmo ricostruito, Nero belgianblue
Reconstructed marble, Black belgianblue



Argilla sabbia
Sabbia clay



LCL Aneto 232

PASSAGE SPACES

Come i riti di passaggio che introducono a nuovi mondi, così gli spazi che collegano un ambiente della casa all'altro preparano, attraverso soluzioni sorprendenti, il ritmo architettonico dell'arredare. Corridoi, spazi intermedi, divisori: ovvero luoghi di passaggio che esigono però la stessa attenzione delle altre stanze. Un'attenzione forse meno funzionale e più decorativa ma il tema rimane sempre quello di un'elegante sinfonia dell'abitare.

Like the rite passages that connect to new worlds, the spaces that connect one area of the house to another through surprising solutions, set the tone of the interiors. Hallways, intermediate areas and vestibules are passage spaces that deserve the same attention as the other rooms. Perhaps the focus is less functional and more decorative, but the theme remains the same: an elegant symphony of home living.





Tavolo, Table **Bulè**
Poltroncina, Armchair **Bea**

Come tessere di un mosaico, le cornici del sistema LT Frame colpiscono per il loro forte impatto grafico dovuto al gioco di incastrati di volumi all'interno del quadrato principale. Cubi in vetro si alternano a composizioni con ante colorate, in un gioco di contenitori a giorno e chiusi. A regalare un ulteriore elemento di fascino contribuisce la luce Led che incornicia il perimetro all'interno, creando così profondità.

Like the tiles of a mosaic, the LT Frames have a graphic visual impact thanks to the insertion of volumes inside the main frame. Glass cubes are alternated with compositions of coloured doors, making for a play of open and closed boxes. Utterior handsomeness is given by Led light framing the perimeter of the back panel and creating depth.





In orizzontale, in verticale, con anta oppure senza. A giorno, trasparente o in una nuance di colore ad effetto. Sono le cornici nella cornice del sistema LT Frame a forte impatto geometrico e cromatico. Speciale l'interno a specchio che si cela dietro l'anta semiaperta.

The LT Frames come with horizontal or vertical elements with or without doors. Open compartments can be transparent or coloured for effect, forming frames inside the frame. LT Frames lend strong geometric and chromatic character to any space. An element of surprise is given by a mirrored back panel, seen here hidden behind a partly open cabinet door.





Materiche, le maniglie in bronzo con lavorazione millerighe, disegnate dall'architetto David López Quincoces.

Textured with pinstripe grooves, the bronze handles were designed by David López Quincoces.



Il ripiano in vetro extrachiario da 6 millimetri di spessore è un'alternativa a quello classico in legno.

A six-millimetre-thick plate of extralight glass is an alternative to the classic shelf in wood.

In contrasto con il legno opaco dell'anta, il top a vassoio dal taglio sartoriale, in tutta larghezza e dello spessore di 10 millimetri, è in finitura laccata lucida.

Contrasting with the door's opaque wood, the top of the cabinet is glossy lacquer with tray-style edging along three sides, 10 millimetres thick.





Oggetti del quotidiano, libri, accessori: in queste immagini, gli elementi a giorno sospesi in vetro trasparente propongono una soluzione originale ed elegante per arredare l'ingresso.

Everyday objects, books, accessories: in these images, the open elements suspended in transparent glass offer an original and elegant solution for decorating the entrance.



BEDROOMS

L'intimità abita qui, nel luogo più ovattato della casa che si illumina d'immenso di giorno e che si prepara ad accogliere atmosfere di pacata dolcezza all'imbrunire. Segreti, progetti, visioni future nascono nella stanza da letto, qui germogliano e da qui si evolvono. Mentre, testimoni silenziosi i mobili contribuiscono alla magia estetica.

This is where intimacy reigns, the most secluded and protective place in the home. Luminous by day and peaceful by night, the bedroom contains secrets, plans and visions for the future that germinate and evolve. The furniture keeps silent watch, contributing to the magic of the room's aesthetic.





Letto, Bed Maddox
Pouf Notch

In camera da letto, il sistema LT40 esplica al meglio la sua essenza di sistema versatile ad alto potenziale di personalizzazione. Qui la boiserie W-Line in legno millerighe, con il suo spessore da 28 millimetri, fa da testiera del letto e sorregge i contenitori pensili trasformati in comodini. Il sistema di pannellatura della boiserie, oltre alla W-Line ha altre tipologie di finitura: in rovere carbone, in noce L, oppure in Lct, la laccatura opaca nei colori rassicuranti di Lema.

In the bedroom, the LT40 system comes into its own. Its versatility and wide-ranging customisation potential are optimally expressed. The headboard is 28-millimetre-thick W-Line wood panelling with pinstripe texture. It is hung with cabinets used as nightstands.

The W-Line panelling comes in other finishes: carbone oak, L walnut, and LCT lacquer in the reassuring colours selected by Lema.





La soluzione con luce Led, oltre a sostituire ulteriori lampade, crea sulla parete un'inedita scenografia luminosa di forte impatto.

An optional Led strip solves the need for more lamps and creates a special scenographic glow on the wall, for a striking effect.



Una struttura in metallo bronzo patinato dalla silhouette sottile regge l'elegante cassettone dallo speciale color terracotta. I capienti cassetti sono dotati di maniglie in finitura bronzo mentre la finitura è in tradizionale Lct, laccato opaco. La peculiarità di questo cassettone è di essere bifronte ovvero rifinito sul retro con un pannello laccato, pertanto può essere posizionato al centro della stanza o in prossimità di una vetrata.

Slender bronze-finish feet raise the elegant chest of drawers off the floor. Seen here in the special colour terracotta, the generous drawers are fitted with bronze-finish handles and lacquered with traditional opaque LCT (Lema Colour Trend). One particular feature of the chest is its lacquer-finished back panel, making it suitable for positioning in the middle of the room or in the proximity of a window.



Il cassettone è composto da quattro cassetti più altri due maxi, come quello aperto che mostra la finitura in greyvelvet della cornice interna in cui si innesta il cassetto, mentre l'interno del cassetto stesso è in grey stone.

Here, the chest is composed of four drawers plus two maxi drawers. The open one shows the inside finish of the side wall in greyvelvet. The inside of the drawer itself is finished in grey stone.





Vanity è un elegante piano d'appoggio solidamente ancorato ad una pannellatura che nasconde un perimetro luminoso. Un progetto caratterizzato da dettagli di ebanisteria rintracciabili nel piano in noce-L, elemento focale del progetto. Uno spazio raffinato ed accogliente per il make-up, o anche angolo discreto per lo smart working. L'armadio Next a cui si accosta è in laccato opaco cameo con elegante maniglia verticale in metallo.

Vanity is an elegant table top solidly anchored to a panelling that hides a luminous perimeter. A project characterized by cabinet-making details that can be found in the L-walnut top, the focal element of the project. A refined and welcoming space for make-up, or even a discreet corner for smart working. The Next wardrobe to which it approaches is in cameo matt lacquer with an elegant vertical metal handle.



Qui proposto in noce-L
 ma disponibile anche
 laccato, Vanity si completa
 con alcuni accessori
 opzionali che contribuiscono
 a personalizzare questo
 spazio intimo: un cassetto
 sotto piano, una piccola
 mensola e uno svuota tasche
 libero che nasconde una
 presa elettrica.

Here proposed in L-walnut
 but also available in lacquer,
 Vanity is completed with
 some optional accessories
 that help to personalize this
 intimate space: a drawer
 under the top, a small shelf
 and a coin tray emptier that
 hides an electrical socket.





WALK-IN CLOSET

L'arte della manutenzione dell'ordine
The art of neatness

Ogni cosa è al suo posto,
nulla è fuori contesto:
la scelta dell'abito giusto
comincia dall'ordinata
ricerca di ogni elemento
del vestire.
Così, anche nella stanza
guardaroba, il sistema
LT40 raggiunge la sua
sublime vocazione di
funzionalità e flessibilità.

Everything has its place;
nothing is out of context.
The choice of the right
outfit starts with an orderly
search for each individual
item of clothing.
The walk-in closet is
another setting in which
the LT40 system reaches
its maximum potential for
functionality and flexibility.



L'Isola LT40 è una soluzione ideale per il centro stanza che completa la zona dedicata agli armadi: gli elementi singoli possono essere accostati tra loro e posizionati schiena contro schiena. I contenitori bassi a cassetti possono alloggiare, in corrispondenza del top, una seduta composta da cuscini imbottiti. L'isola si presta a fornire inediti concetti progettuali multifunzione mettendo in relazione contenitore chiuso, seduta, teca, cassetti, cassettoni e vani con ante o ripiani.

The LT40 Island is an ideal solution for the middle of the room that completes the area dedicated to wardrobes: the individual elements can be placed side by side and positioned back-to-back. The low storage units with drawers can house, at the top, a seat made up of padded cushions. The island lends itself to providing unprecedented multifunctional design concepts by relating closed container, seat, case, drawers, chests of drawers and compartments with doors or shelves.





La teca di LT40 ha un top in vetro e un vano a cassetto, con separatori in pelle sintetica gris: portagioie, anelli, bracciali, orologi e accessori liberamente posizionabili a formare veri e propri espositori personalizzati e dal sofisticato valore estetico.

The LT40 case has a glass top and a drawer compartment, with dividers in gris synthetic leather: jewellery boxes, rings, bracelets, watches and accessories that can be freely positioned to form real personalized displays with a sophisticated aesthetic value.



Cabina Armadio, Walk-in Closet Hangar

Troneggia nel mezzo della stanza guardaroba, l'isola ovvero un duo di cassettoni, uniti da un unico top e attrezzato su entrambi i lati. L'eleganza della forma viene esaltata dalla finitura lucida color nocciola che dialoga con i fianchi e il top in noce-L. Super accessoriata la boiserie che ospita mensole, cassetti, contenitori: tutto per l'ordine di chi ha a cuore l'eleganza e un alto stile di vita.

Standing out in the middle of the wardrobe is an island of twin chests of drawers, back to back, united by a single top and impeccably finished on all sides. The elegance of its shape is flattered by a glossy nocciola colour that combines harmoniously with the sides and top in L-walnut. The wall panelling is super accessorised to host shelves, drawers and boxes, everything needed by everyone who loves orderliness, elegance and stylish living.



Dalle linee leggere, capiente, ad uso di tutti i componenti della famiglia, la cassetiera che si declina attraverso sei cassetti può essere proposta anche doppia, quasi a creare una simmetria totemica dell'ordine. Diventando così un elemento indispensabile dell'arredare.

Its graceful lines contain capacious space for use by all family members. The six-drawer chest can be positioned as twins, turning it into a symmetrical double totem of neatness, an indispensable furnishing element.





Il piano e i fianchi della cassetiera sono in noce-L e incorniciano i cassetti il cui colore può essere scelto nella gamma proposta da Lema. Un elemento di stile, il pomello in metallo brunito; un segno di innovazione, la finitura in greyvelvet, un dettaglio di raffinatezza, l'interno dei cassetti in grey stone.

The top and sides of the chest of drawers are in L-walnut. They frame drawers whose colour can be chosen from the Lema range. Graceful knobs in burnished metal give style. The greyvelvet finish lends a touch of innovation, and the grey stone finish of the drawers' interiors is a detail of refinement.



TECHNICAL INDEX

Composizioni, Compositions – 146

Modularità, Modularity – 152

Abaco contenitori e boiserie, Overview cabinets and panelling
Componibilità, Component elements

Dettagli tecnici, Technical details – 158

Contenitori, Cabinets

Top

Maniglie e base in metallo, Handles and metal base

Pomolo, Knob

LT Frame

Isola, Island

Box

Mensole LPC, LPC shelves

Boiserie, Wall pannel

Panca, Bench

Illuminazione, Lighting

Accessori, Accessories



5.

TECHNICAL SHEET

Coniuga funzione, forma e personalizzazione il sistema LT40 studiato per Lema dall'architetto David López Quincoces. Una perfetta sintesi formale per un importante progetto industriale.

Sistema articolato, frutto di un attento sviluppo industriale LT40 di Lema ha per sua natura la peculiarità di essere personalizzabile poiché gli elementi che lo compongono possono essere abbinabili in infinite soluzioni. Quattro le configurazioni base: contenitori a terra, madie, pensili e boiserie alle quali si aggiungono i contenitori bifronte, vere isole dal duplice uso, i contenitori multimediali e le panche perfette per la fruizione della tecnologia domestica e di home office. Non solo, caratterizzata da un forte impatto estetico, la famiglia LT Frame arricchisce ulteriormente il sistema LT40 con cornici, contenitori, vani a giorno, elementi che con il loro appeal grafico movimentano e impreziosiscono le diverse composizioni. A sublimare l'eleganza del sistema si aggiungono le luci Led che incorniciano perimetri esterni o interni, le finiture interne in greyvelvet oltre a un crossover di materiali quali vetro temperato, noce-L, rovere, laccati opachi e lucidi, argille e marmi.

The LT40 system by Lema is a multiform furniture family, the result of meticulous industrial development. The particularity of the system is its built-in customisation possibilities, seeing how the elements composing it are combinable in infinite ways. There are four basic furniture types: floor-standing cabinets; sideboards; wall-hung units and wood wall panelling. These are joined by island cabinets joined back to back in order to create accessibility on both sides, cabinets for multimedia devices, and benches that are perfect for the tech devices of home and home office. Then there are the LT Frame units designed with a strong aesthetic character. These are a range of framed compositions with open compartments and cabinets inside, forming a three-dimensional graphic effect. Enhancing the elegance of the LT40 system by Lema are Led light strips framing external or internal perimeters; a finish called greyvelvet for the inside of the furniture; and a choice of different materials to incorporate: tempered glass, L-walnut, oak, opaque or glossy lacquer, clay, and different types of marble.

The LT40 system conceived for Lema by David López Quincoces marries function, form and customisation. It is the perfect formal synthesis of an important industrial design project.

Composizioni – Compositions

Living Rooms – p. 16

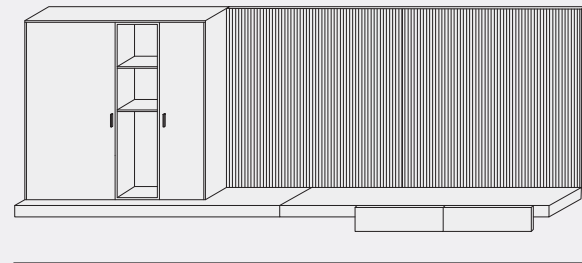

L. 3280 H. 1150 P. 510
W. 129¼" H. 45¼" D. 20"

Living Rooms – p. 22

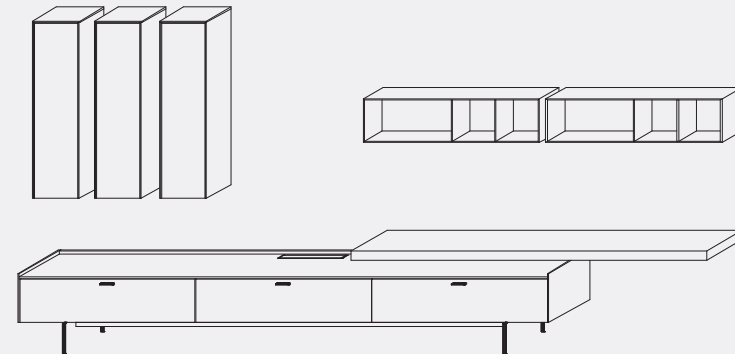

L. 4212 H. 2000 P. 576
W. 165¼" H. 78¼" D. 22¼"

Dining Rooms – p. 42

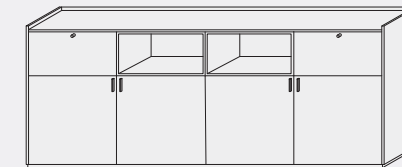

L. 2180 H. 862 P. 476
W. 85¼" H. 34" D. 18¼"

Dining Rooms – p. 48

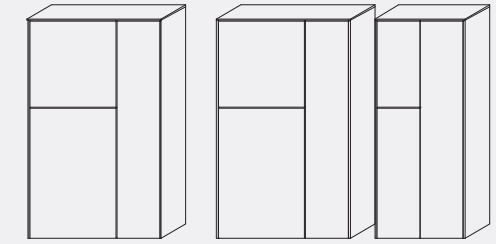

L. 832 – 832 – 562 H. 1360 P. 351
W. 32¼" – 32¼" – 22¼" H. 53½" D. 13¼"

Living Rooms – p. 28

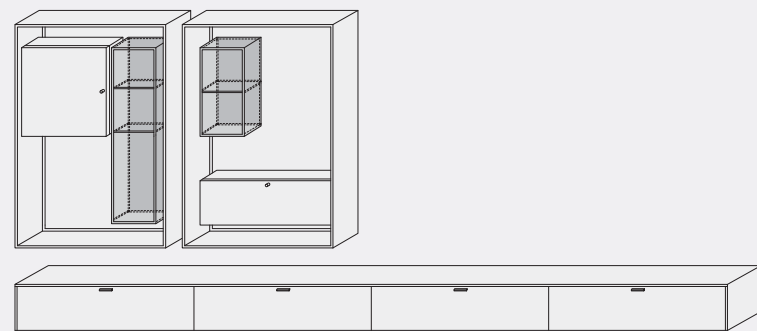

L. 4340 H. 1840 P. 476
W. 170¾" H. 72½" D. 18¾"

Living Rooms – p. 34

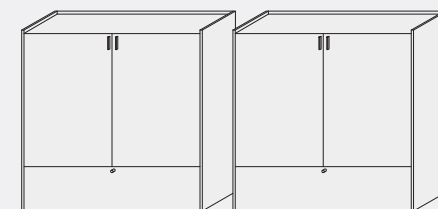

L. 1100 (cad.) H. 1112 P. 496
W. 43¼" (each) H. 43¼" D. 19½"

Dining Rooms – p. 56

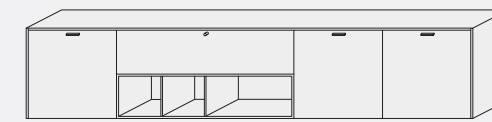

L. 2720 H. 550 P. 496
W. 107" H. 21¼" D. 19½"

Dining Rooms – p. 62

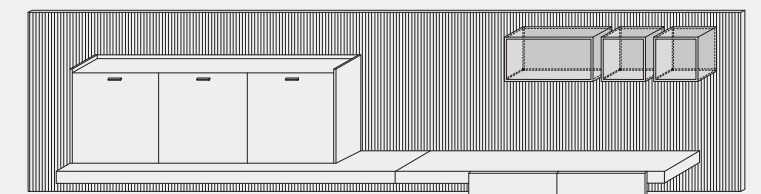

L. 4344 H. 1090 P. 558
W. 171" H. 43" D. 22"

Composizioni – Compositions

Kitchens – p. 70

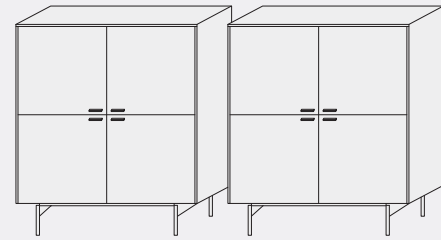

L. 1100 (cad.) H. 1285 P. 476
W. 43¼" (each) H. 50½" D. 18¾"

Home Offices – p. 78

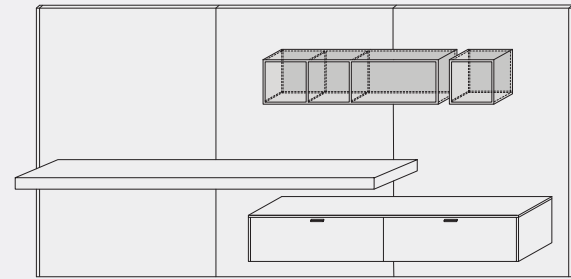

L. 3264 H. 1635 P. 558
W. 128½" H. 64¼" D. 22"

Passage Spaces – p. 108

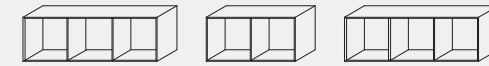

L. 810 – 540 – 810 H. 270 P. 296
W. 32" – 21¼" – 32" H. 10¾" D. 11¾"

Bedrooms – p. 112

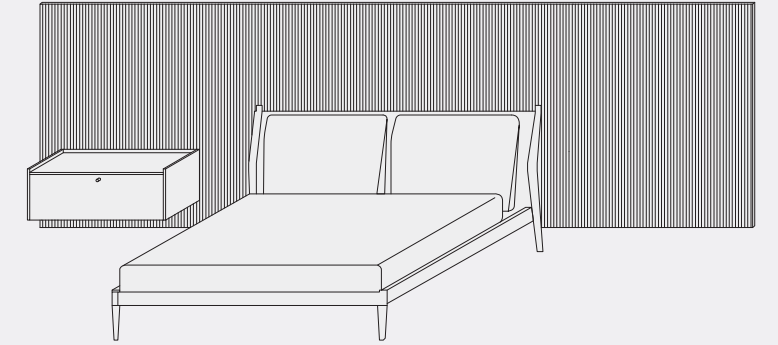

L. 4344 H. 1365 P. 544
W. 171" H. 53¾" D. 21½"

Passage Spaces – p. 96

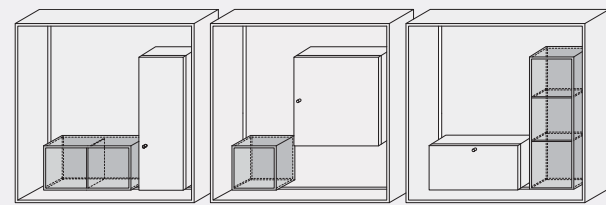

L. 1090 (cad.) H. 1090 P. 351
W. 43" (each.) H. 43" D. 13¾"

Passage Spaces – p. 102

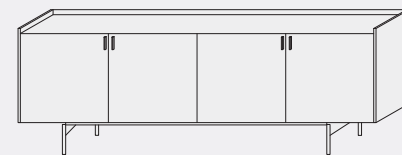

L. 2180 H. 767 P. 476
W. 85¾" H. 30¼" D. 18¾"

Bedrooms – p. 118



L. 1640 H. 845 P. 476
W. 64½" H. 33¾" D. 18¾"

Bedrooms – p. 122

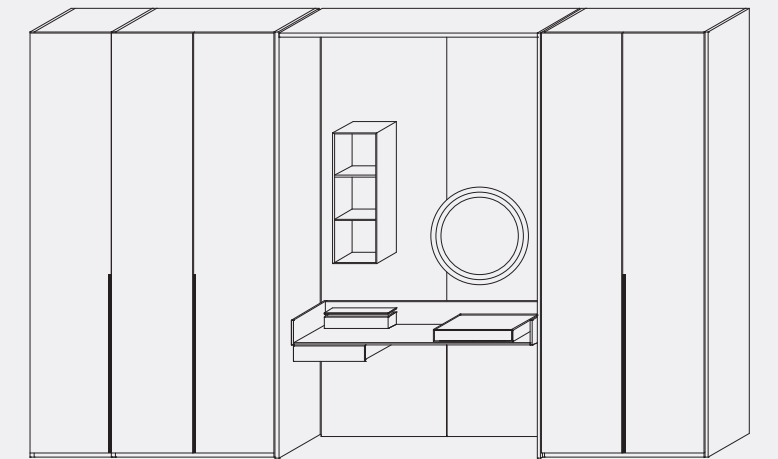

L. 4673 H. 2624 P. 586
W. 184" H. 103¼" D. 23"

Composizioni – Compositions

Walk-in Closet – p. 126

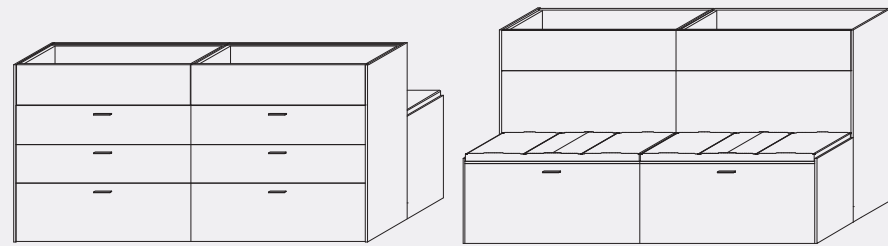

Fronte - Front
L. 2180 H. 840 P. 952
W. 85¼" H. 33 D. 37½"

Retro - Back

Walk-in Closet – p. 132

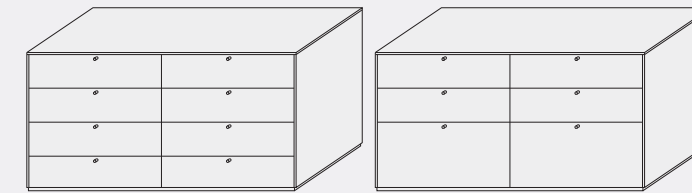

Fronte - Front
L. 1640 H. 770 P. 952
W. 64½" H. 30¼" D. 37½"

Retro - Back

Walk-in Closet – p. 134

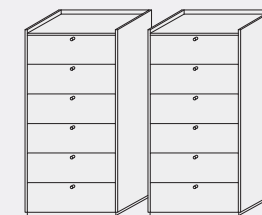

L. 560 (cad.) H. 1132 P. 476
W. 22" (each) H. 44½" D. 18¾"

Contenitori a terra – Floor standing units

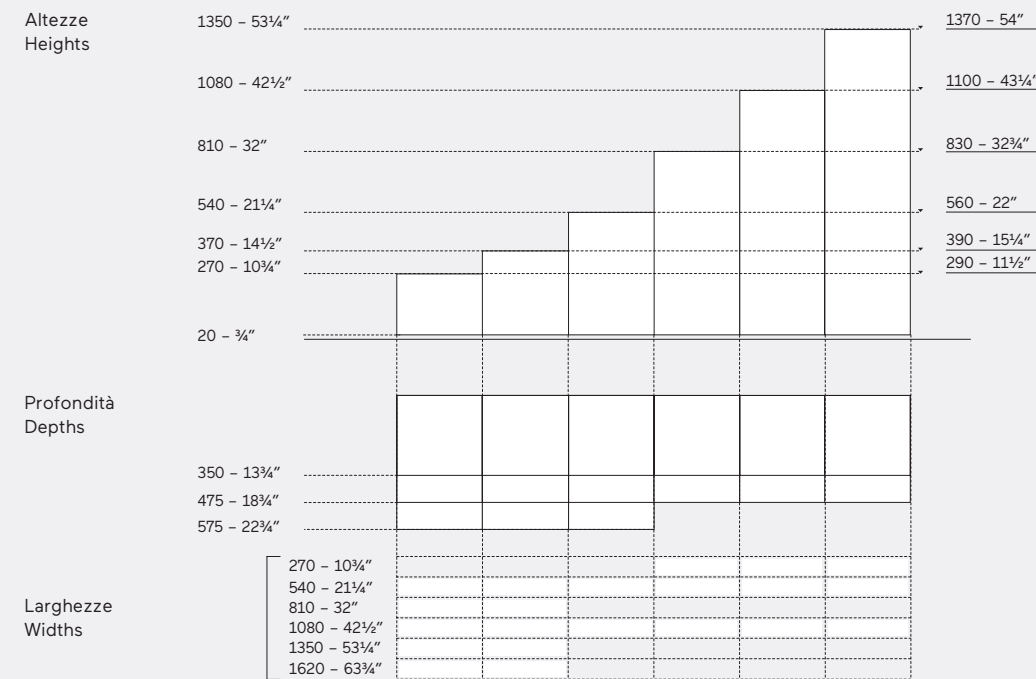

Contenitori a terra bifronte – Floor standing units finished on front and back

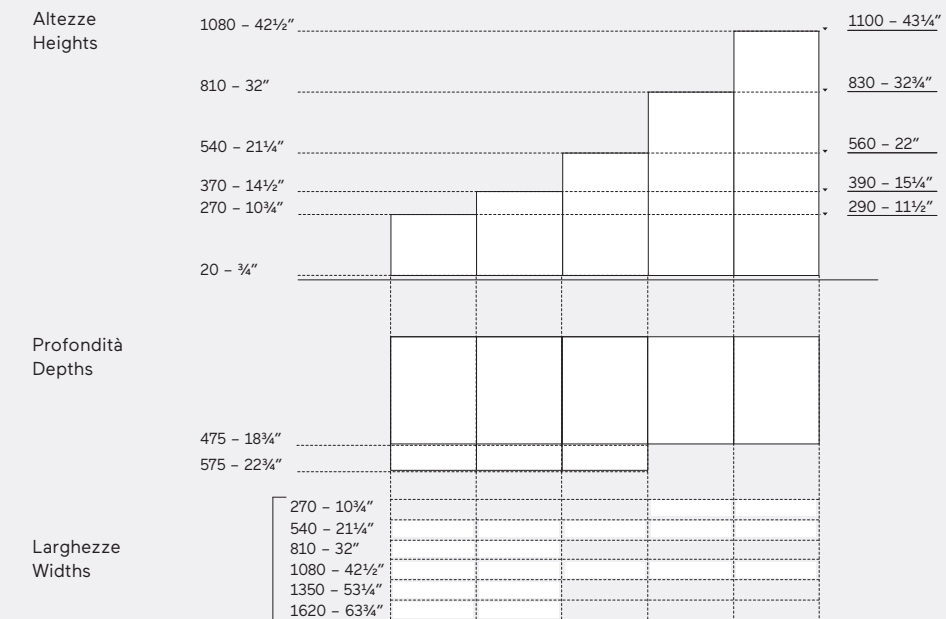

Contenitori pensili – Hanging wall units

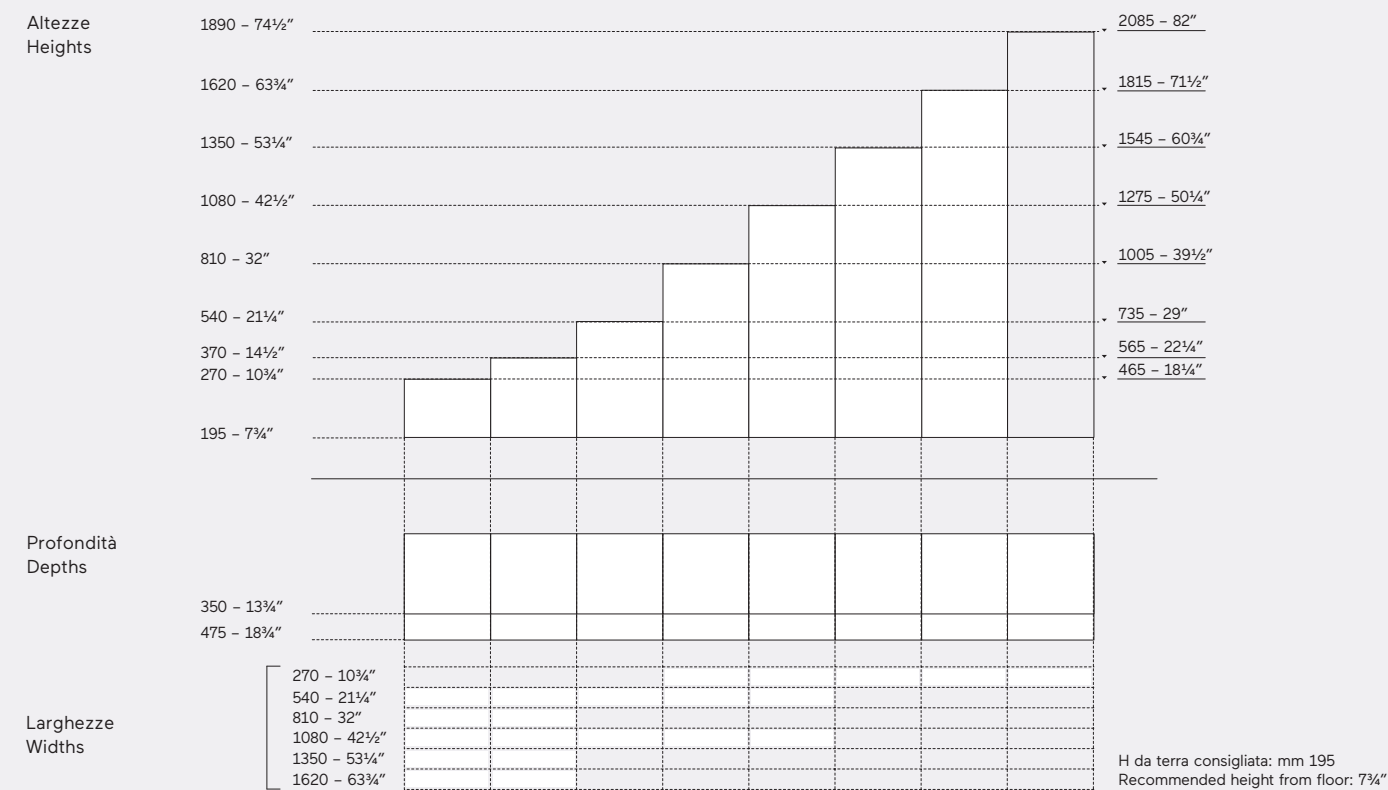

Madia – Madia bifronte Sideboard – Sideboard finished on front and back

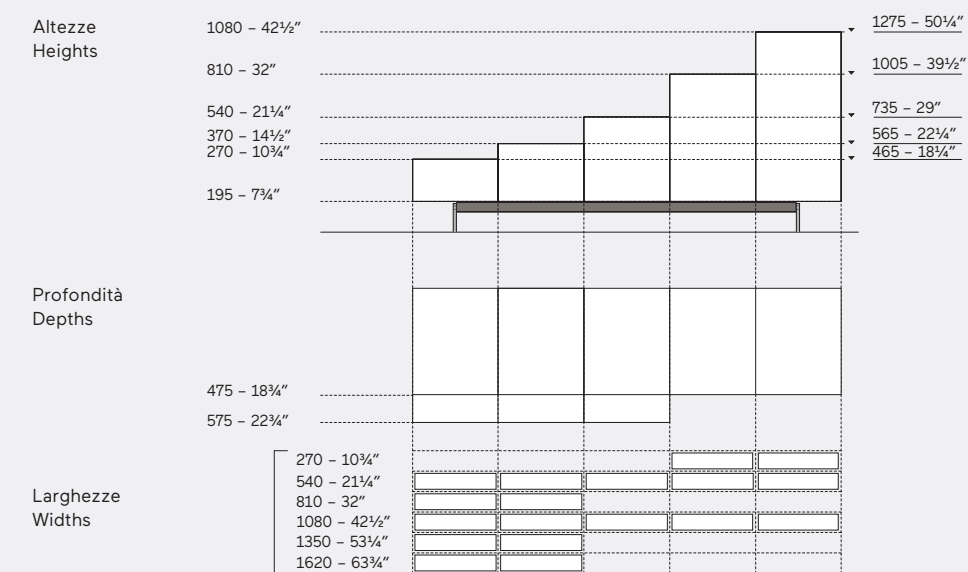

Boiserie W-Line – W-Line wall panel

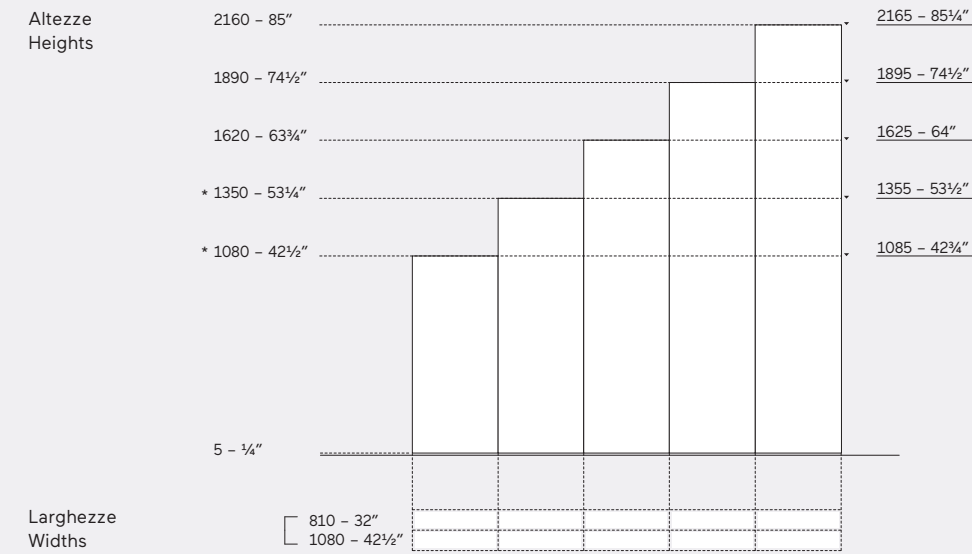

Boiserie essenza – Wooden wall panel

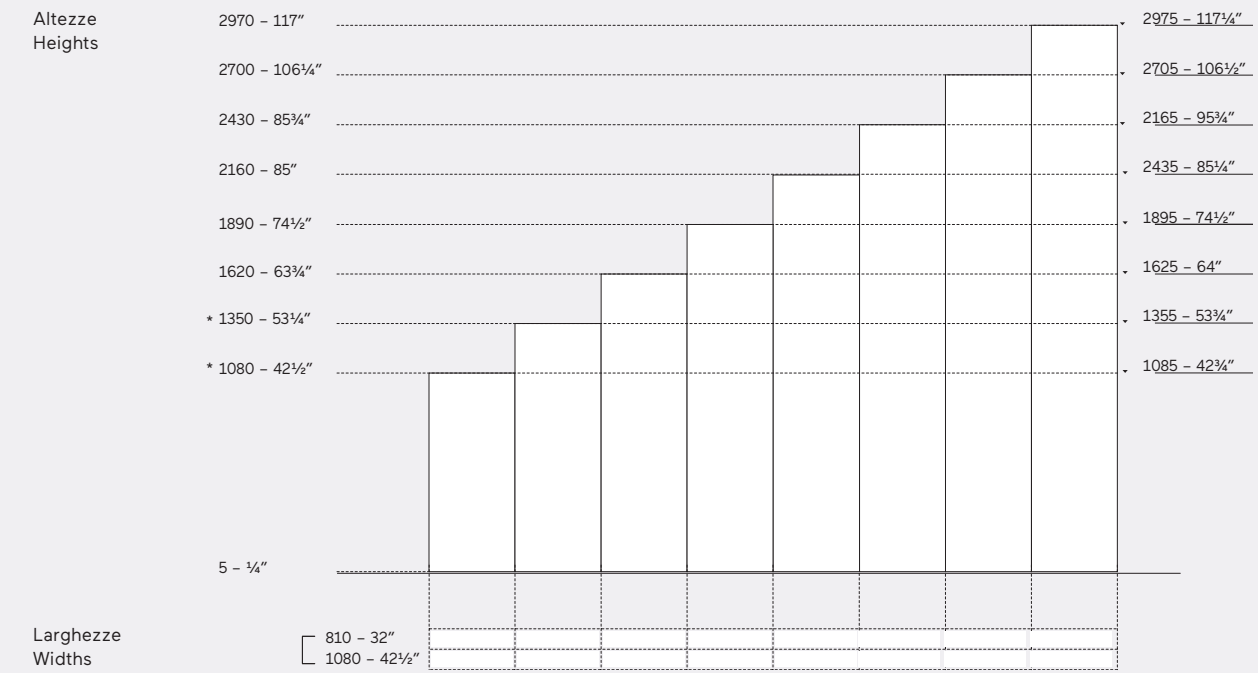

Boiserie Lct – Lct wall panel

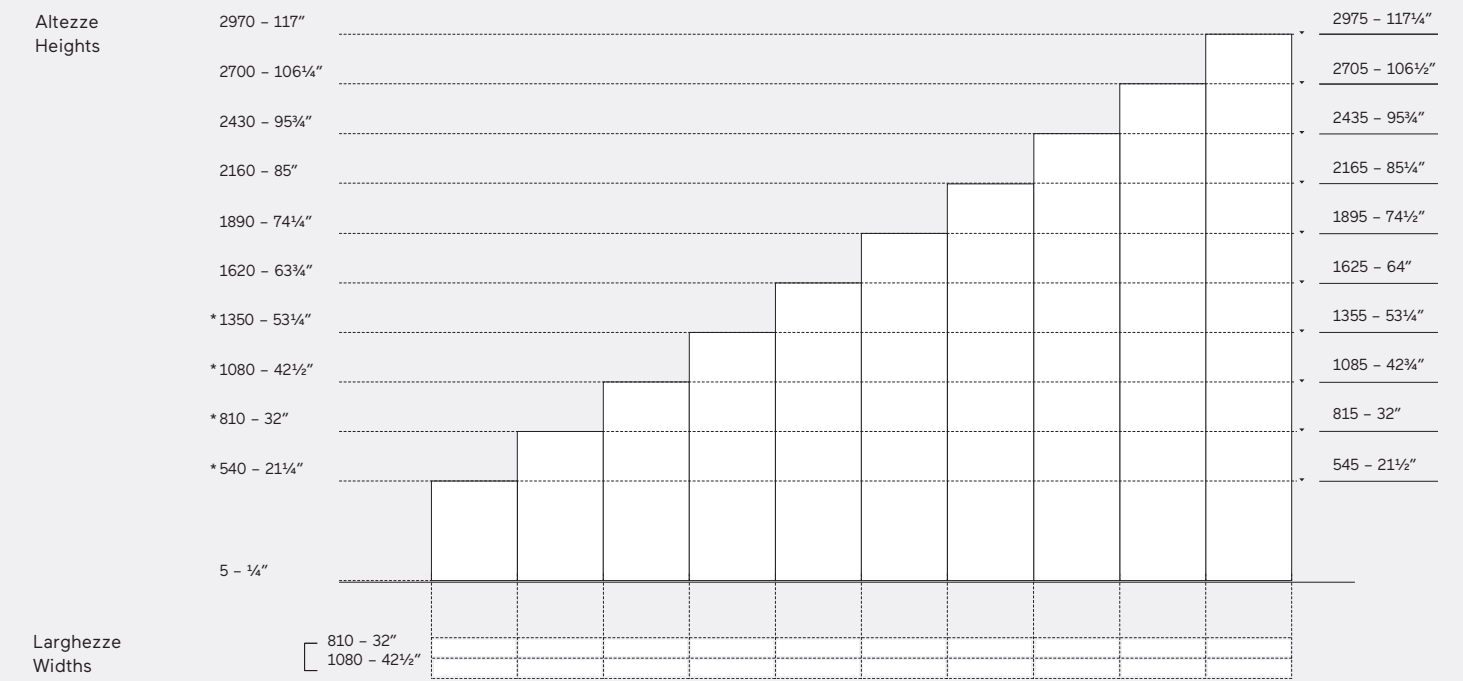

★ La boiserie pensile può avere le seguenti altezze
Wall-hung panelling is available in the following heights

Componibilità sistema – System components

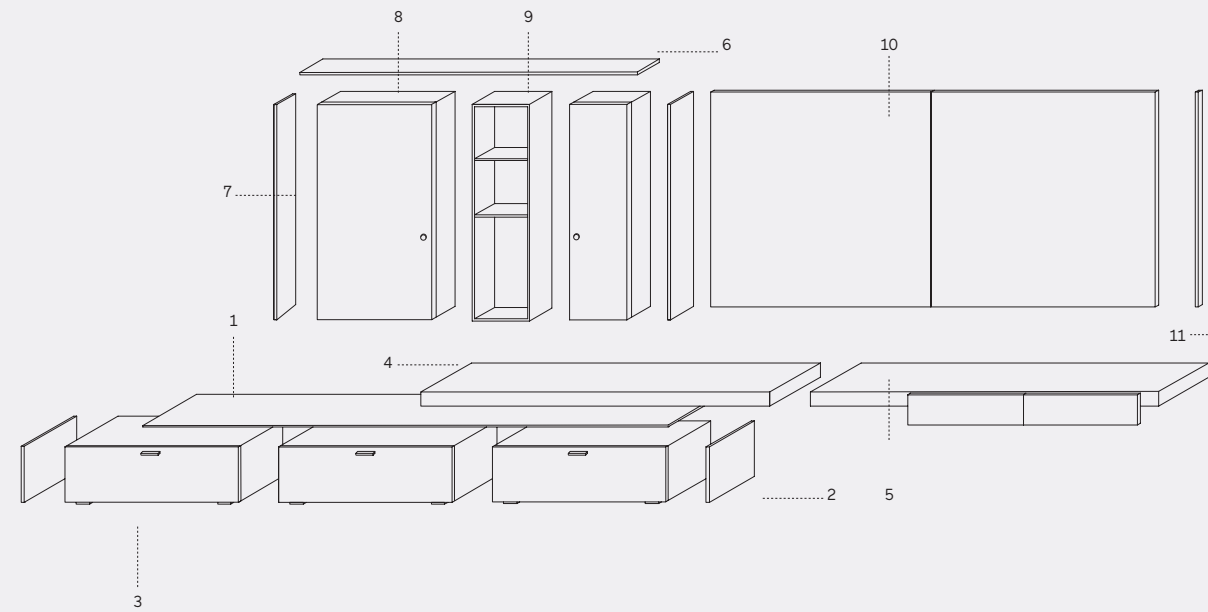

- 1 top di finitura P. 476
 - 2 fianco di finitura per basi a terra
 - 3 contenitore a terra con piedini
 - 4 panca attrezzata
 - 5 panca attrezzata con cassetti
 - 6 top di finitura P. 351
 - 7 fianco di finitura per pensili
 - 8 contenitore pensile
 - 9 box a giorno in legno
 - 10 pannello boiserie
 - 11 profilo di finitura per boiserie
-
- 1 finishing top, depth P. 18¾"
 - 2 end-sides of base
 - 3 floor cabinet with feet
 - 4 bench with cable ducts
 - 5 bench element with twin drawers
 - 6 finishing top, depth P. 13¾"
 - 7 end-sides of wall-hung cupboard
 - 8 wall-hung cupboard
 - 9 open compartment in wood
 - 10 wooden wall panelling
 - 11 edging profile for wall panelling

Componibilità Vanity – Vanity components

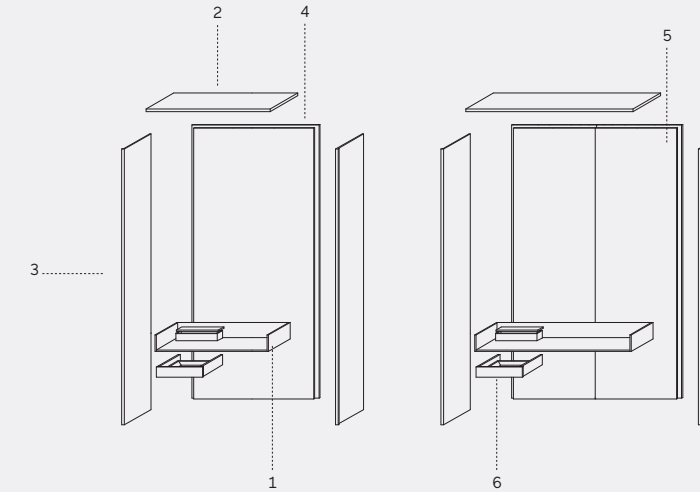

- 1 scrittoio
 - 2 coperchio
 - 3 fianco esterno armadio
 - 4 fondale
 - 5 pannello retroilluminato
 - 6 cassetto
-
- 1 desk
 - 2 top
 - 3 external finishing side
 - 4 back panel
 - 5 backlit
 - 6 drawer

Componibilità madia – Sideboard components

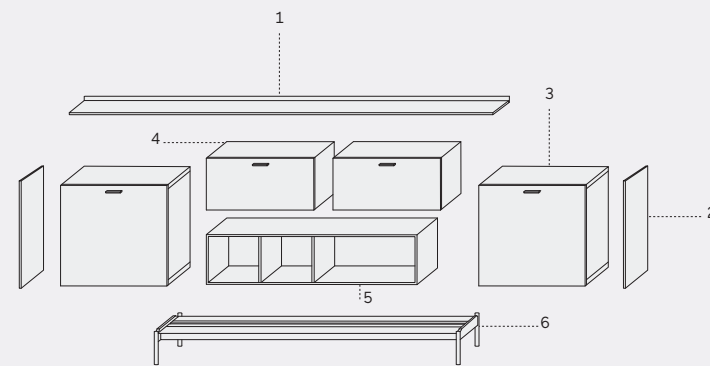

- 1 top vassoio P. 476
 - 2 fianchi di finitura per basi
 - 3 contenitore con anta battente
 - 4 contenitore con cassetto
 - 5 box a giorno in legno
 - 6 base metallo
-
- 1 tray-edged top P. 18¾"
 - 2 end-sides
 - 3 cabinet with hinged door
 - 4 cabinet with drawer
 - 5 open compartment in wood
 - 6 metal structure with feet

Componibilità isola – Island components

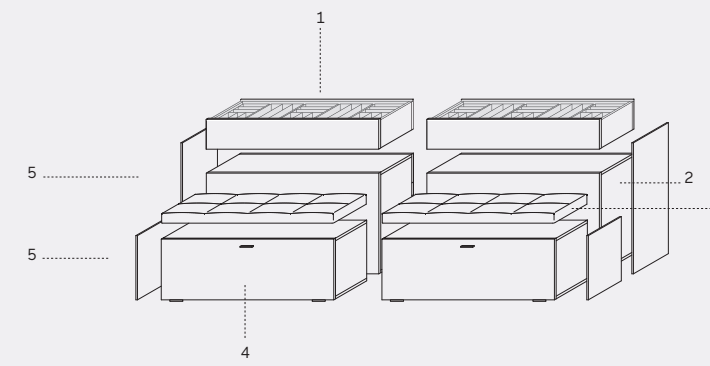

- 1 teca in vetro con vassoio portagioie
 - 2 contenitore a tre cassetti
 - 3 cuscino seduta
 - 4 cassettone
 - 5 fianco di finitura
-
- 1 jewel case with glass top
 - 2 three drawers unit
 - 3 seat cushion
 - 4 high drawer
 - 5 finishing sides

Contenitori – Cabinets

Anta battente – Hinged door

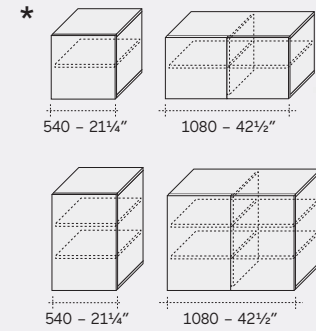
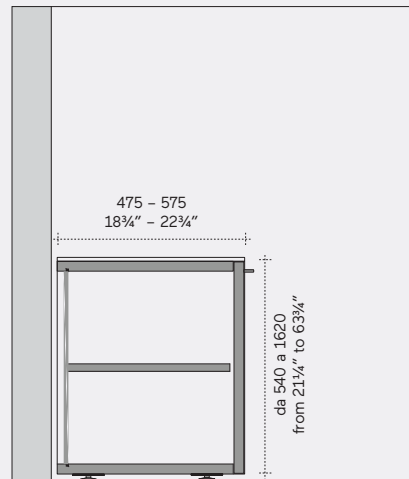

Disponibile a terra anche nella versione bifronte.
P. 350 - 475 per la versione pensile.
Floor-standing version available with finished back.
Wall-hung version either 13 3/4" or 18 3/4" deep.

Cassetti – Drawers

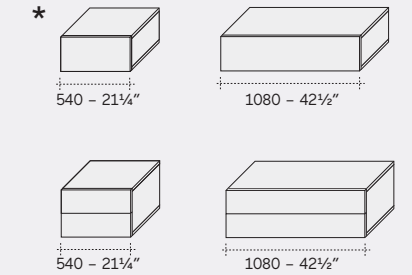
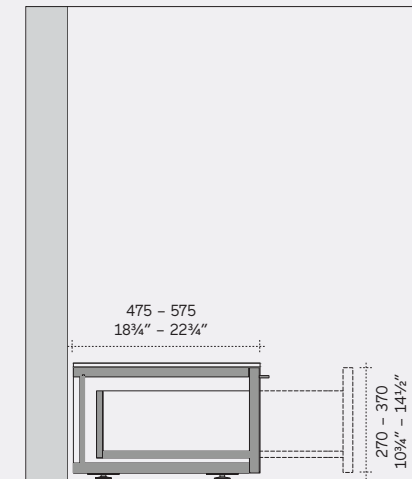

Disponibile a terra anche nella versione bifronte.
P. 475 per la versione pensile.
Floor-standing version available with finished back.
Depth of wall-hung version: 18 3/4".

Anta ribalta – Flap door

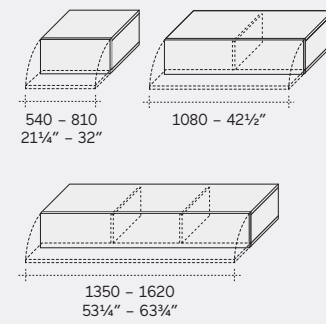
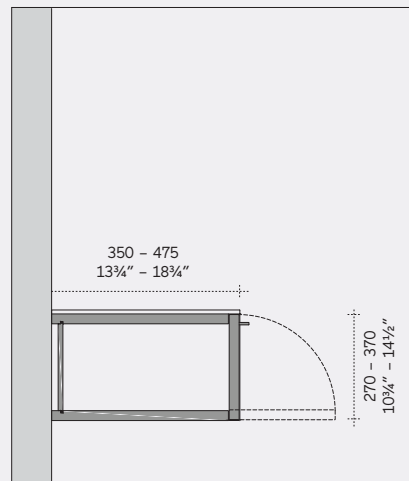

Disponibile a terra anche nella versione bifronte.
P. 350 - 475 - 575 per la versione a terra.
Floor-standing version available with finished back.
Available depths of wall-hung version: 13 3/4" - 18 3/4" and 22 3/4".

Multimedia – Multimedia unit

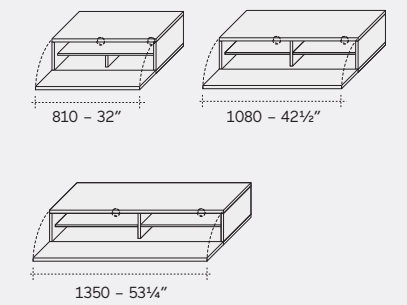
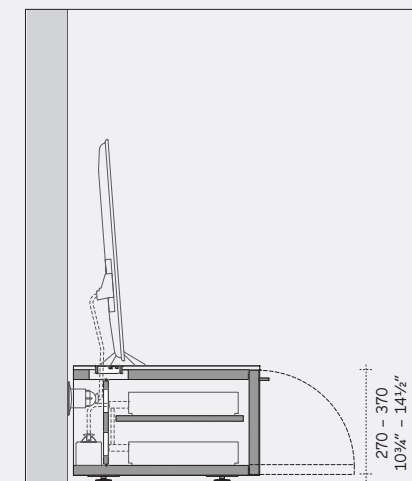

Disponibile nella versione a terra P. 475 - 575.
P. 475 per la versione pensile.
Available depths of floor-standing version: 18 3/4" and 22 3/4". Depth of wall-hung version: 18 3/4".

Anta ribalta a salire – Flap door upwards

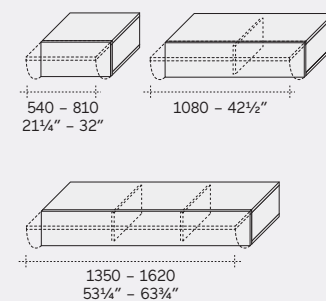
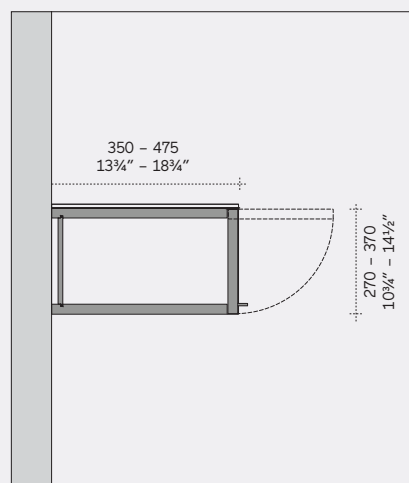

Disponibile solo nella versione pensile.
Available only in wall-hung version.

Multimedia totem

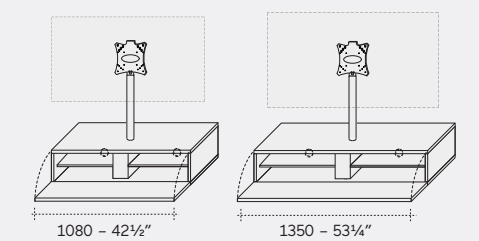
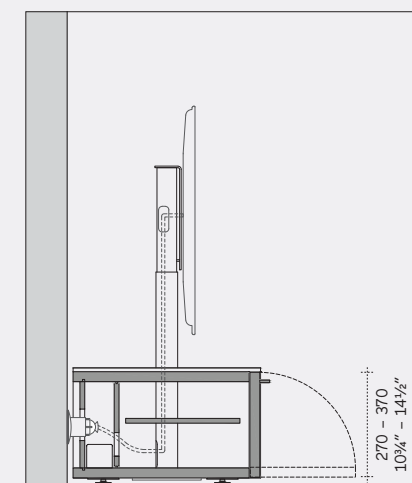

Totem orientabile per TV da 40" a 55".
Dimensioni supporto H. 680 - 780, Ø 55.
Disponibile solo nella versione a terra P. 475 - 575.
Adjustable support for television sizes 40" to 55".
Support height from 26 3/4" to 30 3/4", Ø 2 1/4".
Available only in floor-standing version in the depths 18 3/4" and 22 3/4".

Top

Top spessore 10 mm – Thick 1/4" top

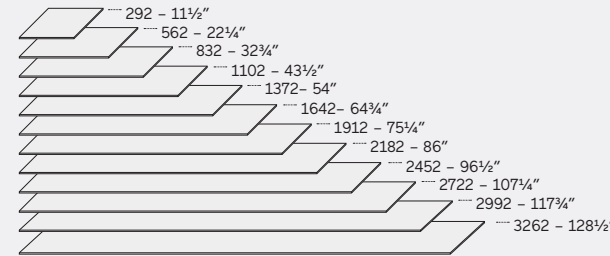
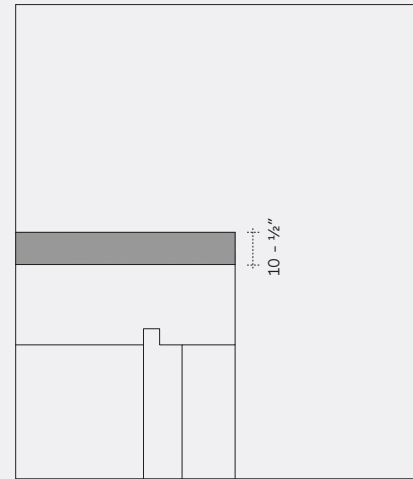

Disponibile anche in versione bifronte in finitura LCT, LCL, rovere carbone e noce-L, argilla e marmo ricostruito.
Available with finished back. Materials: LCT lacquer, LCL lacquer, carbone oak, L-walnut, clay and reconstructed marble.

Top vassoio – Tray top

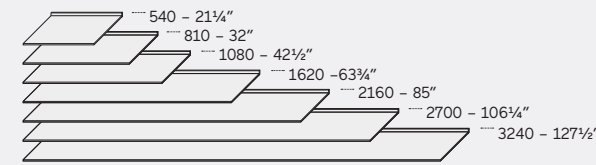
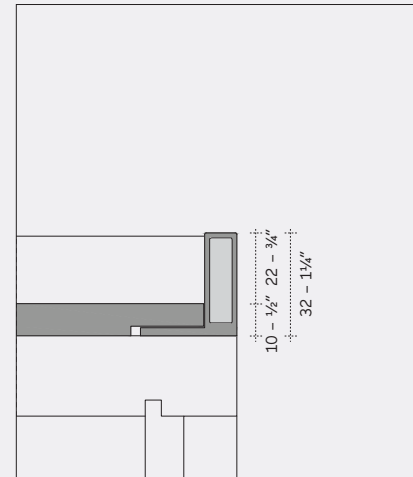

Disponibile anche in versione bifronte in finitura LCT, LCL, rovere carbone e noce-L, argilla e marmo ricostruito.
Available with finished back. Materials: LCT lacquer, LCL lacquer, carbone oak, L-walnut, clay and reconstructed marble.

Top pietra/marmo per vassoio – Stone or marble tray-style tops

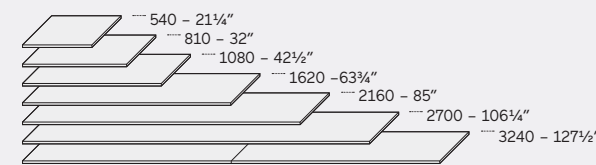
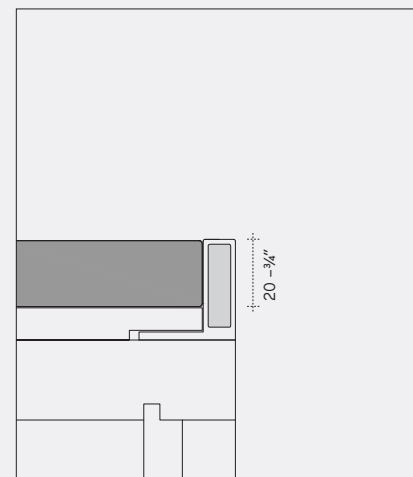

Disponibile anche in versione bifronte in finitura pietra Grey e marmo Portoro.
Available with finished back in the materials Grey stone and Portoro marble.

Maniglie e base in metallo – Handles and metal base

Maniglia – Handle

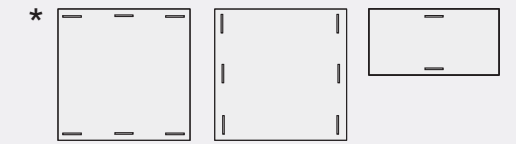
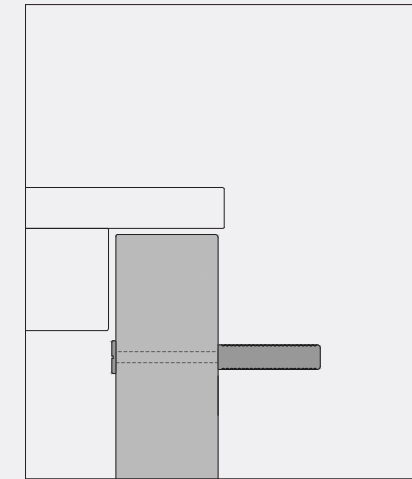

* Schema di posizionamento maniglia su anta e cassetto/ribalta. Dimensioni maniglia L. 75 P. 25 H. 6. Disponibile in finitura bronzo patinato M422 o laccata LCT.
Diagram of handle positioning on doors, drawers, drop-front drawer and lift-up drawer.
Size of handle: W. 3" D. 1" H. 3/4". Available with patinated bronze finish M422 or LCT-lacquered.

Pomolo – Knob

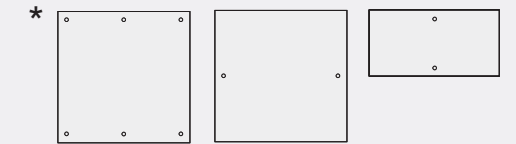
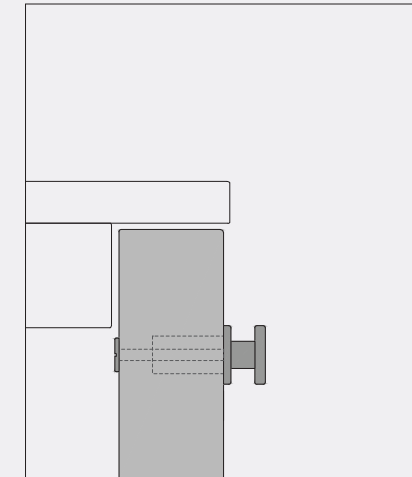

* Schema di posizionamento pomolo su anta e cassetto/ribalta. Dimensioni pomolo Ø 14 P. 10. Disponibile in finitura bronzo patinato M422.
Diagram of knob positioning on doors and drawers.
Size of knob: Ø 1/2" D. 1/4". Available with patinated bronze finish M422.

Base metallo, base metallo con luce – Metal structure with feet and version with Led light

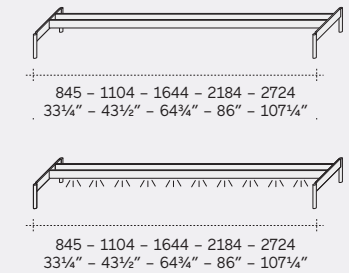
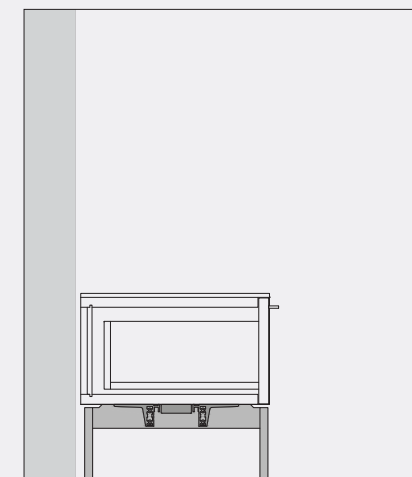

Dimensioni base metallo P. 462 – 562 H. 195
Finitura in bronzo patinato M422. Disponibile anche in versione bifronte con o senza luce.
Dimensions of metal structure: D. 18 1/4" – 22 1/4" H. 7 3/4"
Finishing: M422 coated painted bronze
Available with finished back, and with or without Led strips.

LT Frame

Tipologie frame – Frame types



LT Frame configura 12 composizioni suddivise in due tipologie dimensionali. Elementi pensili arricchiti da colore, legno, trasparenze e da luce Led che ne esalta il perimetro interno.

LT Frames come in 12 different predetermined compositions and 2 sizes. These are wall-hung units enriched with colour, wood, glass and Led strips that light up the inner perimeter of the back panel.

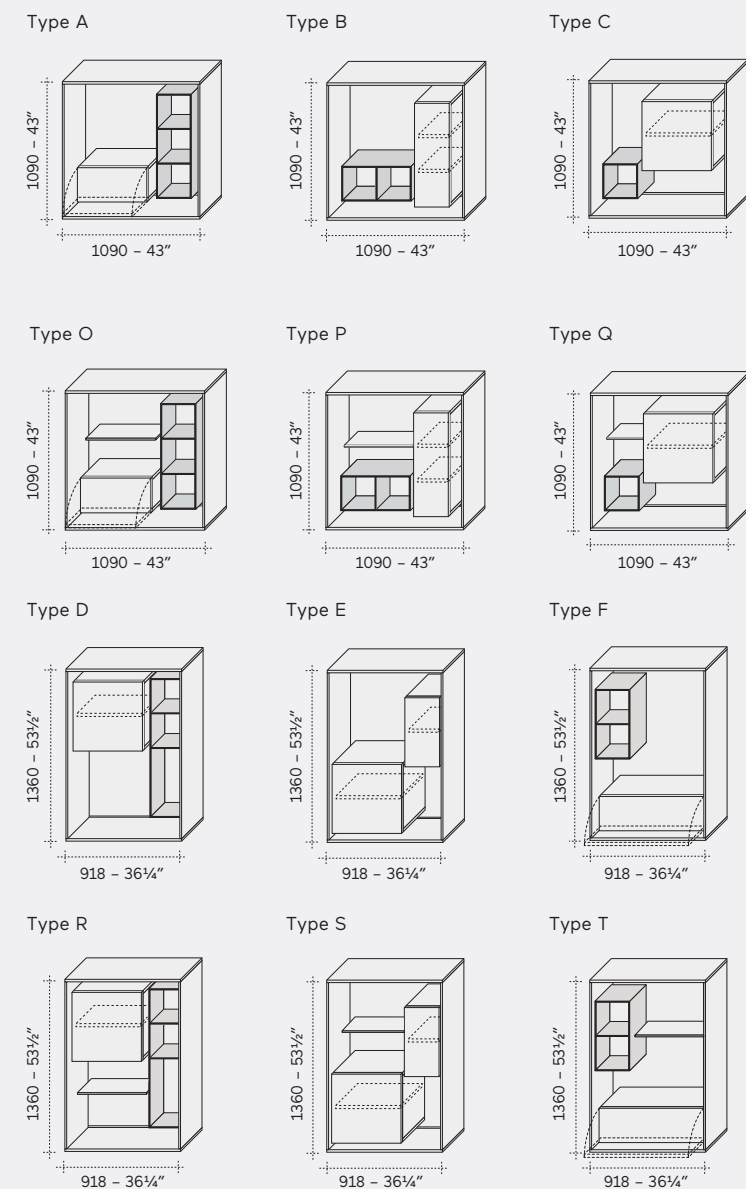

Isola – Island

Tipologie isola – Island types

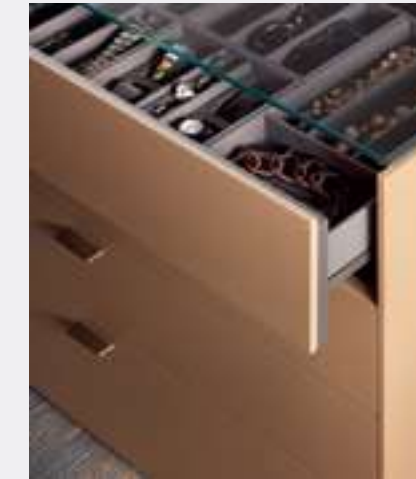

Isola è una possibilità compositiva per ambienti come la cabina armadio, in cui si richiede l' inserimento di contenitori freestanding, utilizzabili su due fronti, organizzabili in modo differente.

Isola is a compositional possibility for rooms like the wardrobe where a free-standing chest of drawers is required that offers use from both sides, each of which can be organised in a different way.

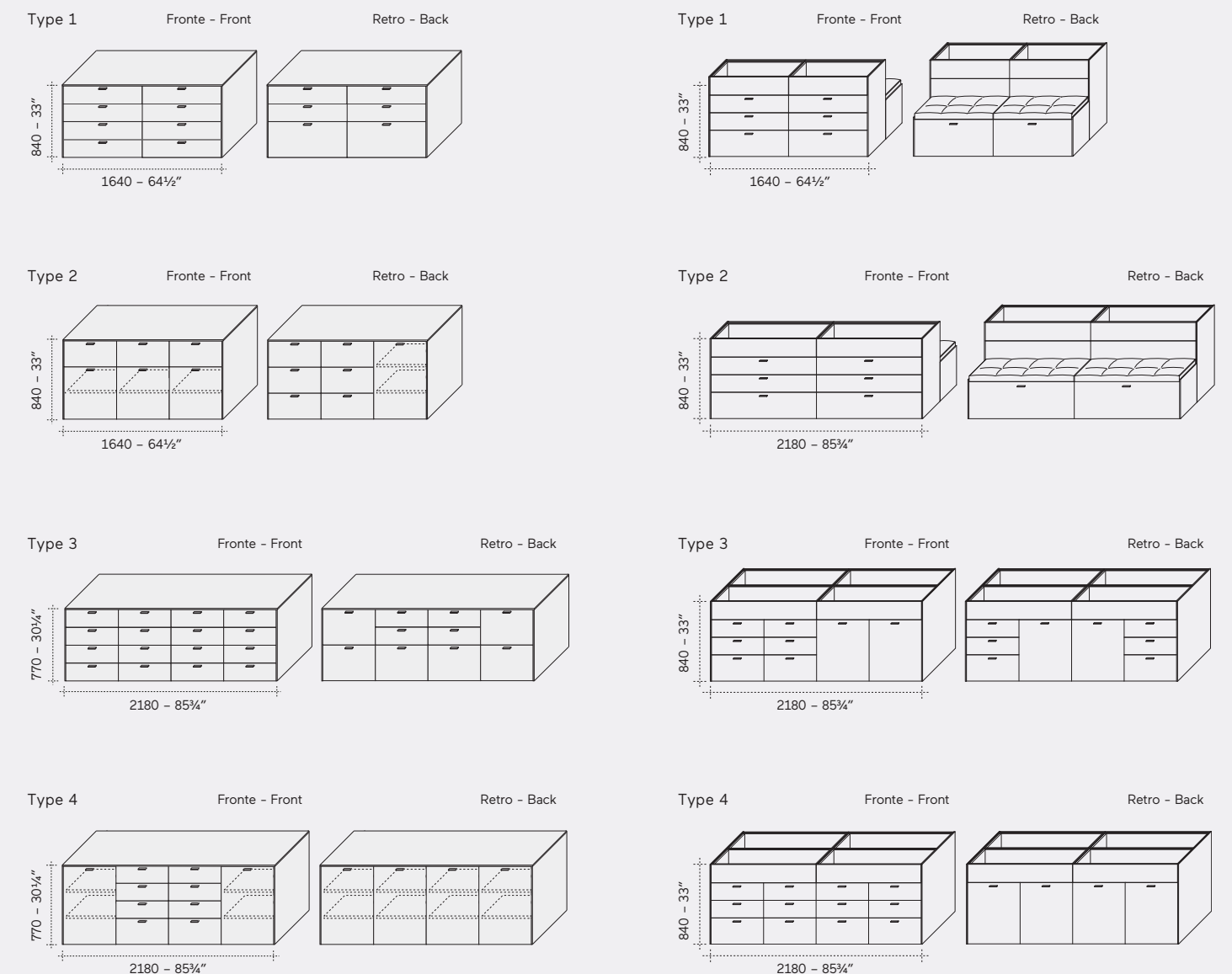

Box

Box vetro – Glass box

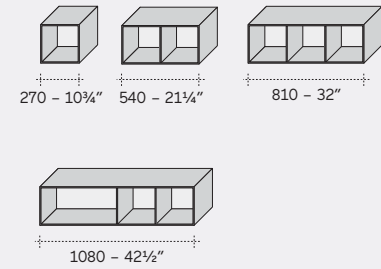
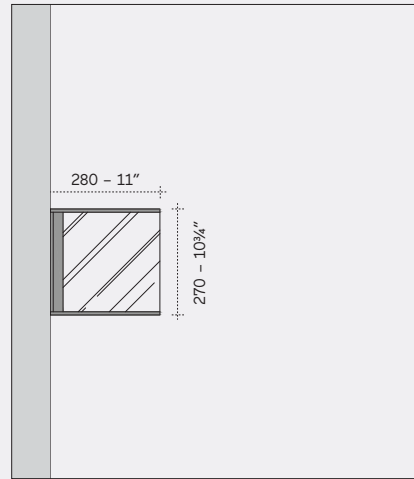

Disponibile in versione verticale ed orizzontale.
Schienali in finitura LCT o LCL.
Available in vertical and horizontal versions.
Back panel lacquered in LCT or LCL.

Box legno – Wood box

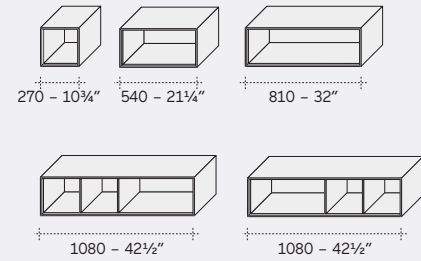
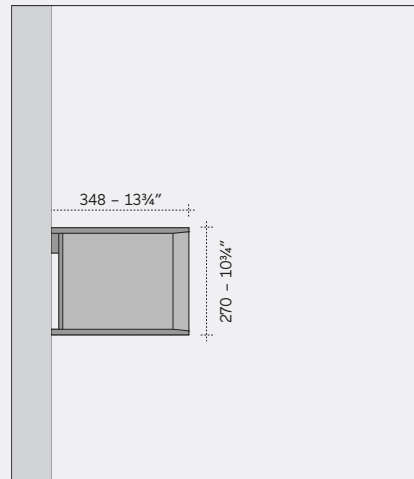

Disponibile in versione verticale ed orizzontale
in finitura LCT, LCL, rovere carbone e noce-L.
Available in vertical and horizontal versions.
Available finishes: lacquered in LCT or LCL,
carbone oak and L-walnut.

Box legno integrato – Wood box used as integral part of unit

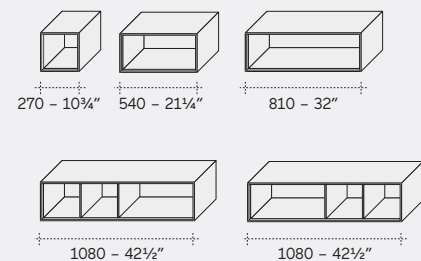
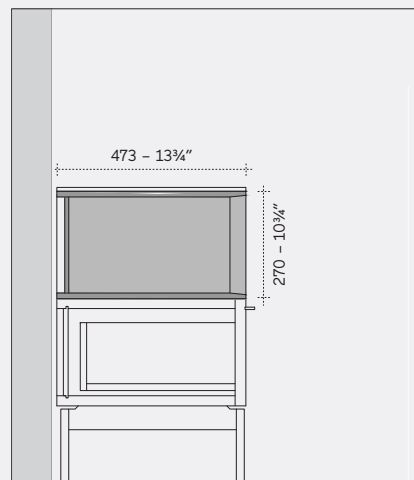

Disponibile in versione verticale ed orizzontale
in finitura LCT, LCL, rovere carbone e noce-L.
Available in vertical and horizontal versions.
Available finishes: lacquered in LCT or LCL,
carbone oak and L-walnut.

Mensole LPC – LPC shelves

Mensola L – L shelf

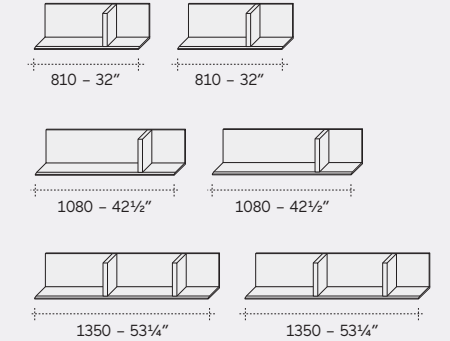
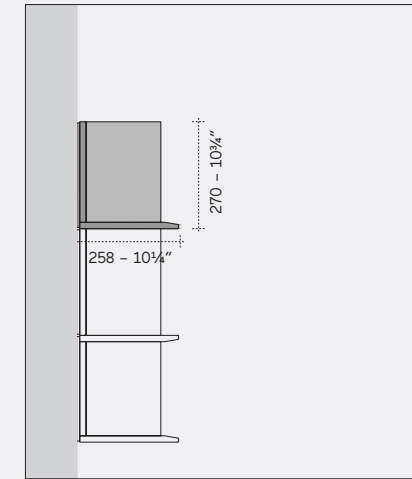

Disponibile in finitura LCT, LCL, rovere carbone
e noce-L.
Available finishes: lacquered in LCT or LCL,
carbone oak and L-walnut.

Mensola P – P shelf

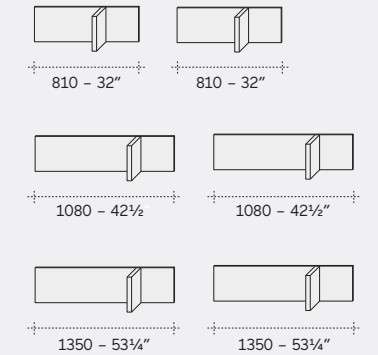
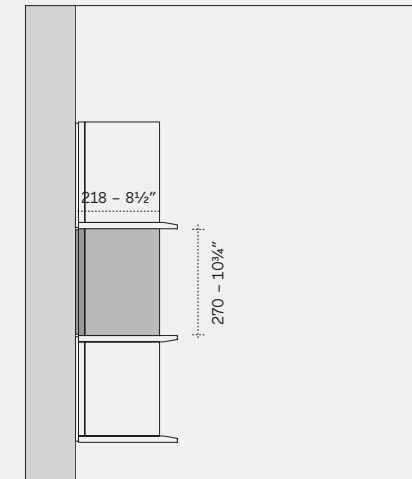

Disponibile in finitura LCT, LCL, rovere carbone
e noce-L.
Available finishes: lacquered in LCT or LCL,
carbone oak and L-walnut.

Mensola C – C shelf

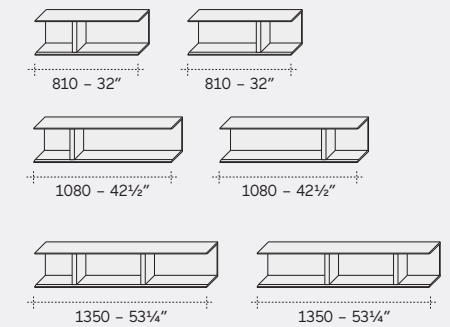
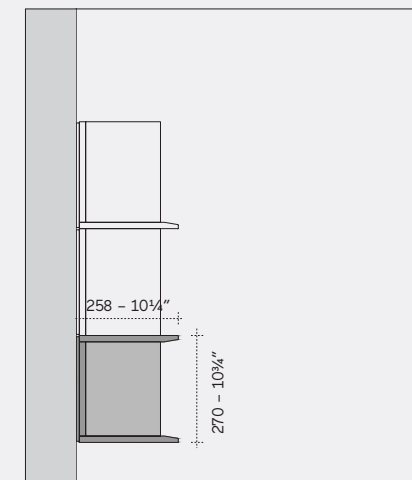

Disponibile in finitura LCT, LCL, rovere carbone
e noce-L.
Available finishes: lacquered in LCT or LCL,
carbone oak and L-walnut.

Boiserie – Wall panel

Boiserie a terra – Floor-standing wall panelling

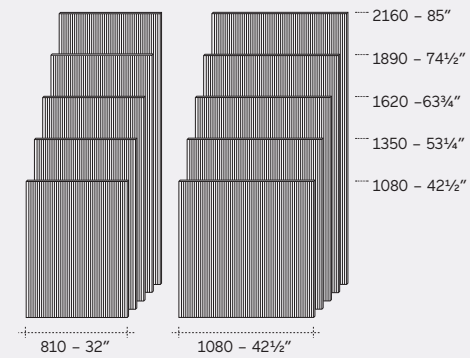
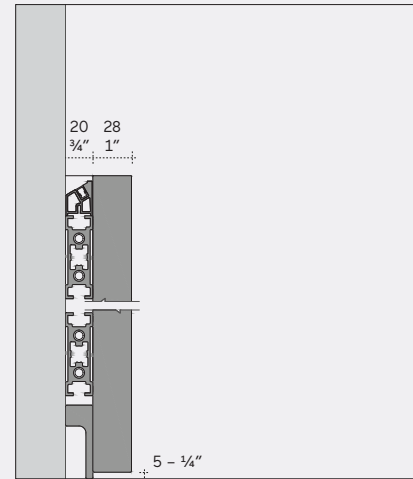

Disponibile in finitura W-line, essenza e LCT.
Available in W-line, wood and LCT finishing.

Panca – Bench

Panca attrezzata – Bench with cable ducts

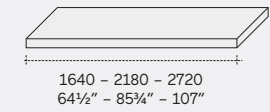
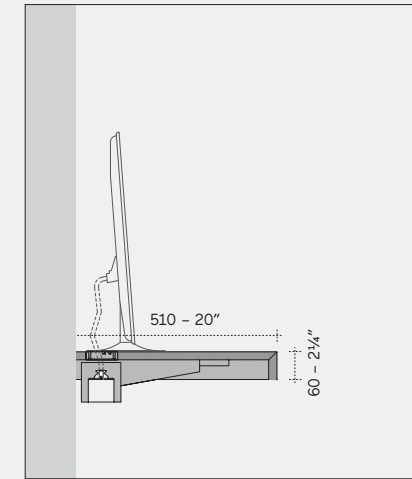
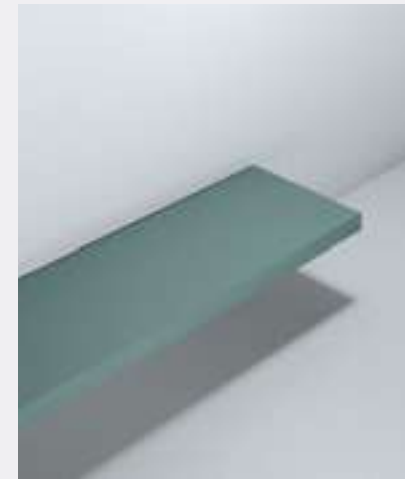

Disponibile in finitura LCT, LCL, rovere carbone e noce-L, argilla e marmo ricostruito.
Possibilità di ancoraggio a parete o boiserie.
Available finishes: lacquered in LCT or LCL, carbone oak and L-walnut, clay and reconstructed marble.
Can be anchored to wall or panelling.

Boiserie su contenitore/panca – Cabinet and bench standing wall panelling

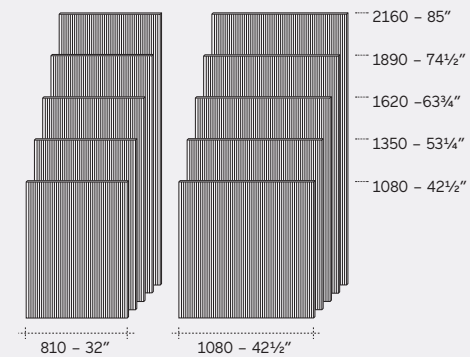
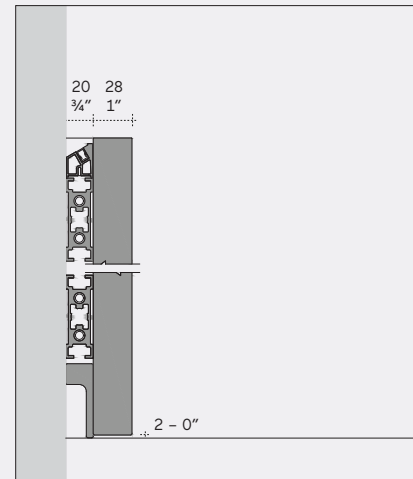

Disponibile in finitura W-line, essenza e LCT.
Available in W-line, wood and LCT finishing.

Cassetto per panca – Bench drawer

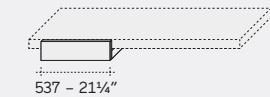
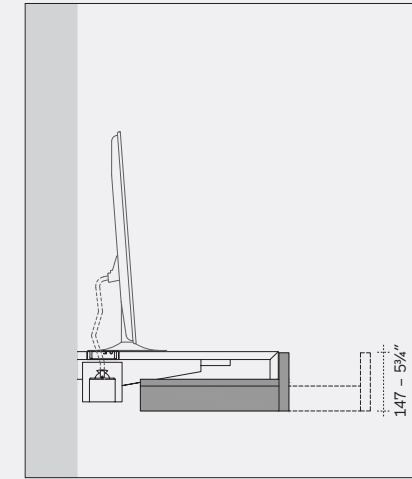

Frontale disponibile in finitura LCT, LCL, rovere carbone e noce-L, argilla e marmo ricostruito.
Front panel available lacquered in LCT or LCL, carbone oak, L-walnut, clay and reconstructed marble.

Boiserie pensile – Wall-hung panelling

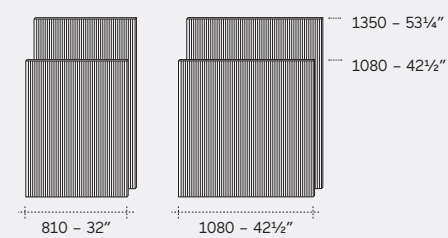
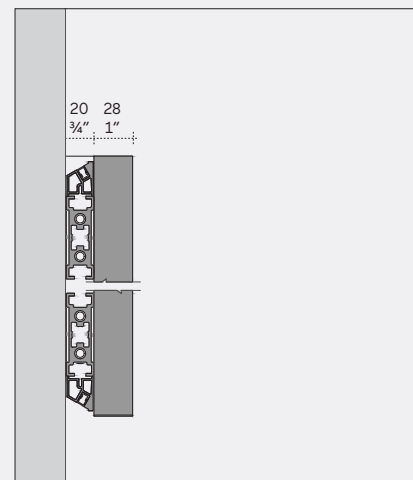

Disponibile in finitura W-line, essenza e LCT.
Available in W-line, wood and LCT finishing.

Panca scrittoio – Writing desk

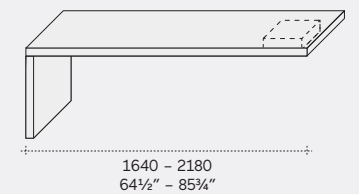
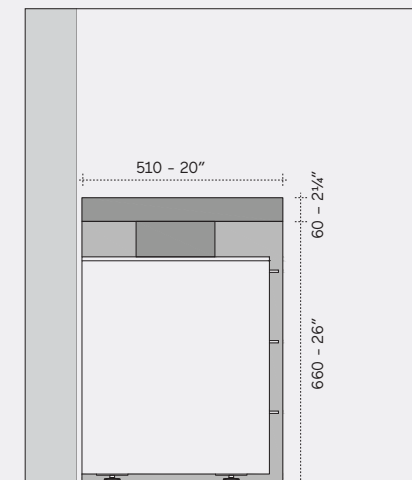

Disponibile in finitura LCT, LCL, rovere carbone e noce-L, argilla e marmo ricostruito.
Available lacquered in LCT or LCL, carbone oak, L-walnut, clay and reconstructed marble.

illuminazione – Lighting

illuminazione contenitori – Cabinet lighting

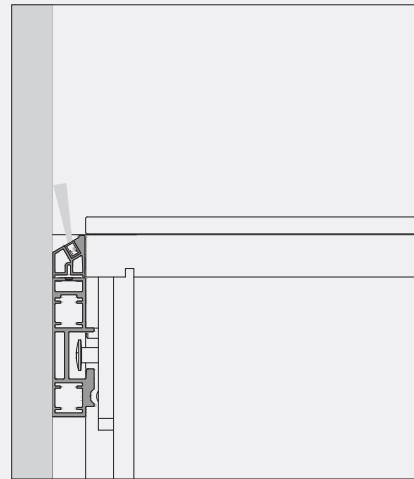

Lampada stripe Led per retroilluminazione superiore e inferiore per contenitori pensili.
Gradazione calda 3000° K.
Led strip for back-lighting of the upper and lower edge of wall-hung cabinets.
Warm light: 3,000 degrees Kelvin.

illuminazione boiserie – Panelling lighting

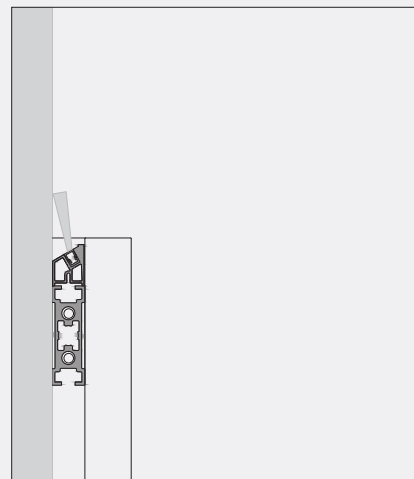

Lampada stripe Led per retroilluminazione superiore e inferiore per boiserie. Gradazione calda 3000° K
Led strip for back-lighting of the upper and lower edge of wall panelling.
Warm light: 3,000 degrees Kelvin.

illuminazione base metallo – Metal base structure lighting

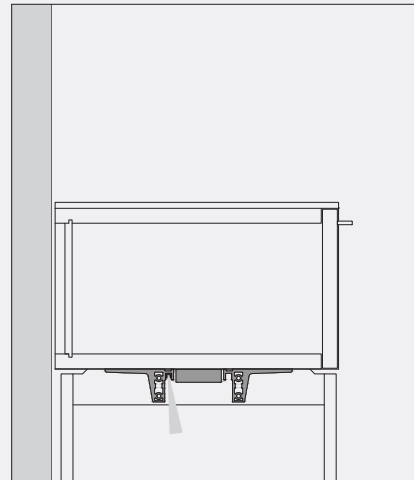

Lampada stripe Led per illuminazione inferiore base metallo. Gradazione calda 3000° K.
Led strip for illumination underneath furniture.
Warm light: 3,000 degrees Kelvin.

Accessori – Accessories

Faretto interno per contenitore – Inside spotlight for cabinets

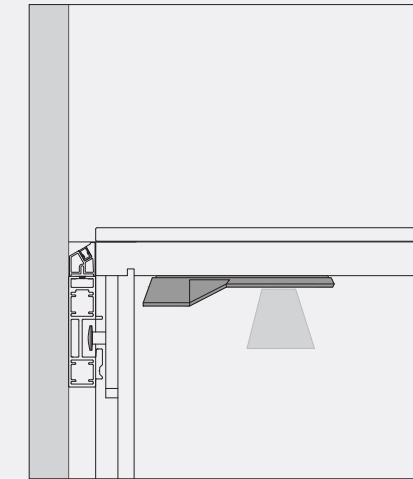

Faretto a batteria ricaricabile per interno contenitore
Cover colore Greyvelvet con logo Lema impresso.
Dimensioni L. 141,5 H. 22 P. 80
Gradazione calda 3000° K.
Spotlight powered by rechargeable batteries for illumination inside cabinets. Greyvelvet-coloured cover stamped with Lema logo.
Size of lamp: W. 5½" H. ¾" D. 3¼"
Warm light: 3,000 degrees Kelvin.

LT smart charger

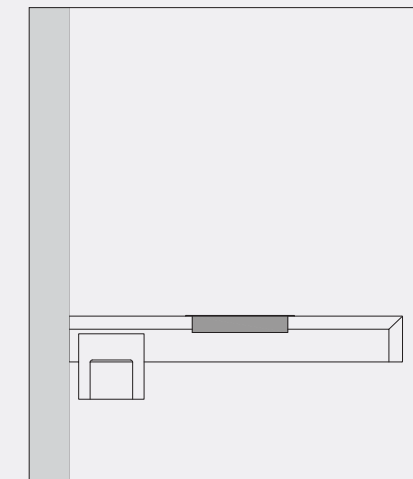

Vano svuotatasche con doppia carica USB per smart device, utilizzabile su panche. Finitura metallo verniciato bronzo M420.
Dimensioni L. 277 H. 25 P. 166
Tray for miscellaneous items, equipped with two USB ports to recharge devices. Usable on Lema benches. M420 painted bronze.
Size of tray with ports: W. 11" H. 1" D. 6½"

Cover alimentatore – Power supply cover

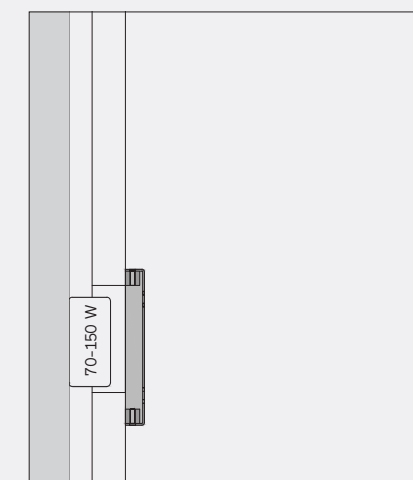

Cover di accesso al cablaggio per lampade.
Finitura metallo verniciato bronzo M420.
Dimensioni L. 290 H. 131 P. 16
Cover for access to light wiring.
M420 painted bronze.
Size of cover: W. 11½" H. 5¼" D.¾"

6.

SAMPLES COLLECTION

Lemacolorlucido LCL — 172

Lemacolortrend LCT — 173 , 174

Argille, Clay — 174

Essenze, Woods — 175

Marmi, Marbles — 175

Marmi ricostruiti, Reconstructed marbles — 175

Melaminici, Melamine — 175

Metalli, Metals — 175

Lemacolorlucido

			
Paper 227 LCT Carta 750 •	Bianco 200 LCT Latte 405 •	Scoglio 212 LCT Sabbia 910 •	Nocciola 213 LCT Ombra 803 •
			
Seta 244 LCT Cameo 930 •	Caramello 245 LCT Biscotto 932 •	Agave 243 LCT Pistacchio 928 • *	Ortica 235 LCT Salvia 835 •
			
Aneto 232 LCT Timo 480 •	Persia 241 LCT Avio 476 •	Ruta 231 LCT Assenzio 479 •	Alloro 240 LCT Lauro 924 •
			
Oro 247 LCT India 936 •	Miele 239 LCT Curry 922 •	Ciliegia 216 LCT Amarena 828 •	Granata 238 LCT Bruciato 477 •
			
Marna 237 LCT Basalto 920 •	Talpa 233 LCT Terra 805 •	Danubio 242 LCT Cobalto 926 •	Grigio 205 LCT Fumo 906 •
			
Alga 222 LCT Fango 471 •	Nero 215 LCT Lavagna 713 •	Corrispondenza in LCT • Correspondence in LCT •	

Lemacolortrend

			
Mango 845	Terracotta 478	Amarena 828	Bruciato 477
			
Cameo 930	Biscotto 932 *	India 936	Curry 922
			
Pistacchio 928	Salvia 835	Timo 480	Avio 476
			
Lauro 924	Assenzio 479	Ottano 847	Cobalto 926
			
Oltremare 469	Lavagna 713	Fumo 906	Grafite 918
			
Fango 471	Basalto 920	Antimonio 870	Ghiaia 913

Lemacolortrend — LCT

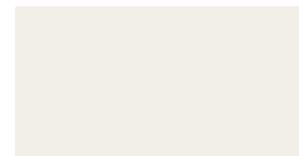

Cigno 700

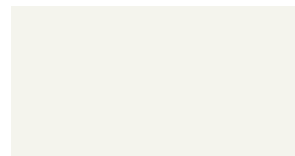

Carta 750

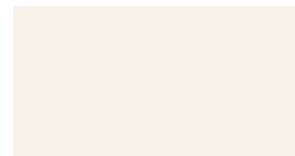

Latte 405



Canapa 707



Calcare 801



Sabbia 910



Ombra 803



Pepe 804



Cacao 461

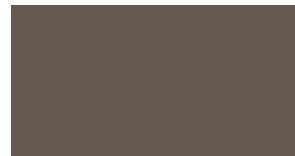

Terra 805



Moro 934

Argille, Clay



Ardesia

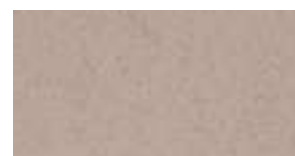

Creta

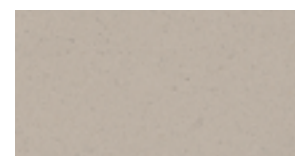

Polvere



Sabbia



Pece

Essenze, Woods



Rovere - oak carbone



Noce - walnut L



W-line

Marmi, Marbles



Portoro marble



Pietra - grey stone

Marmi ricostruiti, Reconstructed marbles



Verde - green malachite



Blu - blue lapislazzuli



Nero - black belgianblue

Melaminici, Melamine



Greyvelvet



Stone

Metalli, Metals



Bronzo patinato M422

Ad+Design
Photos
Styling
Text
Translation
Repro + Print

Graph.X
Santi Caleca, Thomas Pagani
Studio Salaris, Ufficio Stile Lema
R+W, Antonella Matarrese
Lema, Wendy Wheatley
Ogm, 2021

Thanks to

101 Copenhagen
Amini carpets
Artycraft
Atmosphere d'Ailleurs
Barbera/Madelli
Bottega intreccio
Carpet Edition
CC Tapis
Cecchi e Cecchi
Cesare Castelli
Circolo 1901
Flos
Forestier
GT Design
Ilaria Franza Painting
L'Opificio 1998 Torino Italia
Luceplan
Market Set
Mason Editions
Mohebban Milano
Nahoor
Nemo Lighting
Novocquadro
Paola Paronetto
Pulpo
Restart Milano
Ro Smit
Sklo studio
Texturae
Utopia&Utility
Vetrofuso
Wallace Sewell
Zp Studio

关注LEMA微信公众号
Follow LEMA WeChat account



公众号 ID : LemaOfficial

Lema S.p.a.
22040 Alzate Brianza
Como — Italia
Strada Statale
Briantea N° 2
T. +39 031 630 990
lemamobili.com