

**LEMA**  
**JOURNAL**  
NEW  
STORIES  
**EDITION '22**  
→

**LEMA**

LEARN MORE ON [LEMAMOBILI.COM](https://www.lemamobili.com)

LEMA  
JOURNAL  
NEW  
STORIES  
EDITION '22  
→

In-Between — p. 6  
Claire — p. 12  
Ombra — p. 18  
Francis — p. 24  
Fred — p. 30  
Dolmen — p. 36  
Niveaux — p. 42  
Glee — p. 50  
Groovy — p. 56  
Ayra — p. 60

LEMA

The Lema factory in Alzate  
Brianza designed by Angelo  
Mangiarotti



**IT** Il dna stilistico di Lema si esprime nella nuova collezione 2022 grazie al contributo di designer diversi per stile e metodo progettuale, a volte minimalista a volte più decorativo, a sottolineare ancora una volta la capacità aziendale, di riunire approcci diversi per comporre una collezione articolata, ma sempre coerente. Arredi su misura concepiti per dialogare tra loro, dove le diverse scelte cromatiche, materiche e le innumerevoli possibilità di abbinamento, svelano le molteplici sfumature dell'abitare secondo Lema. Scelte apparentemente in contrasto, capaci di rivelare ad uno sguardo attento il fil rouge che le lega: l'alta sartorialità made in Italy.

**EN** Lema's stylistic dna is expressed through the new 2022 collection thanks to the contribution of different designers both in terms of style and design method, at times minimalist and at times more decorative, underlining the company's ability to bring together different design approaches to compose an articulated collection, that is always consistent. Custom-made furnishings designed to dialogue with each other, where different chromatic and material choices unite with the countless combination possibilities and reveal the many nuances of lifestyle according to Lema. Apparently contrasting choices, capable of revealing the fil rouge that binds them at a glance: fine made in Italy tailoring.

**IT** Il tavolo da pranzo diventa protagonista della zona giorno grazie al disegno della base che esalta in maniera inaspettata lo spazio, in un'alternanza di aperture e chiusure. Influenze orientali si combinano al gusto occidentale in una proposta dallo stile sofisticato che non rinuncia alla convivialità.

**EN** The dining table becomes the protagonist of the living area thanks to the unique design of the base enhancing the space in an unexpected way, in an alternation of openings and closings. Oriental influences combine with Western style in a sophisticated proposal for conviviality.

## IN-BETWEEN Table →



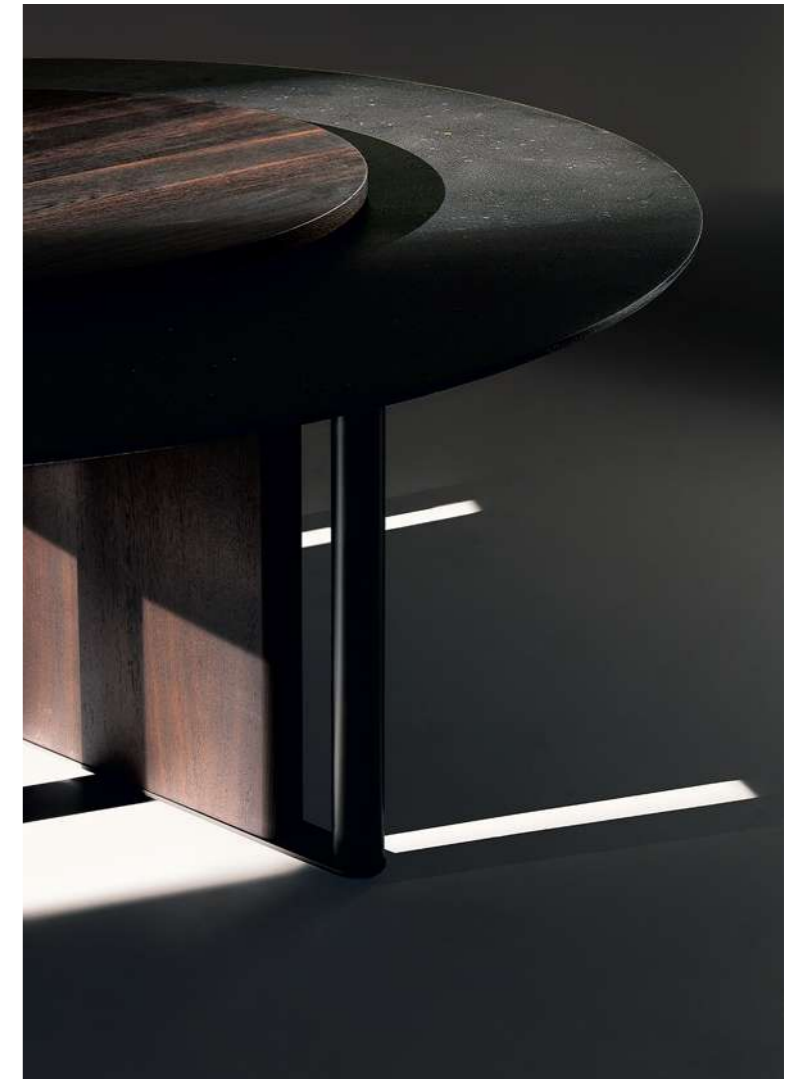

**IT** La base scultorea di In-Between dona bidimensionalità all'ambiente, rivelando una personalità dinamica che domina lo spazio. Il piano rotondo disponibile in diverse finiture, sfiora la base donando ancora più leggerezza all'intera figura.

**EN** The sculptural base of In-Between gives two-dimensionality to the environment, revealing a dynamic personality dominating the space. The round top, available in different finishes, touches the base, giving lightness to the whole design.

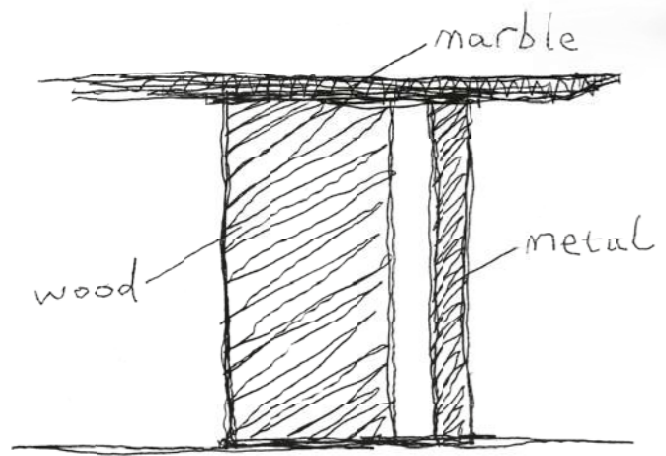

MARMO BIANCO CARRARA



ROVERE TERMOTRATTATO



BRONZE PAINTED  
M420



# FINISHINGS Proposals

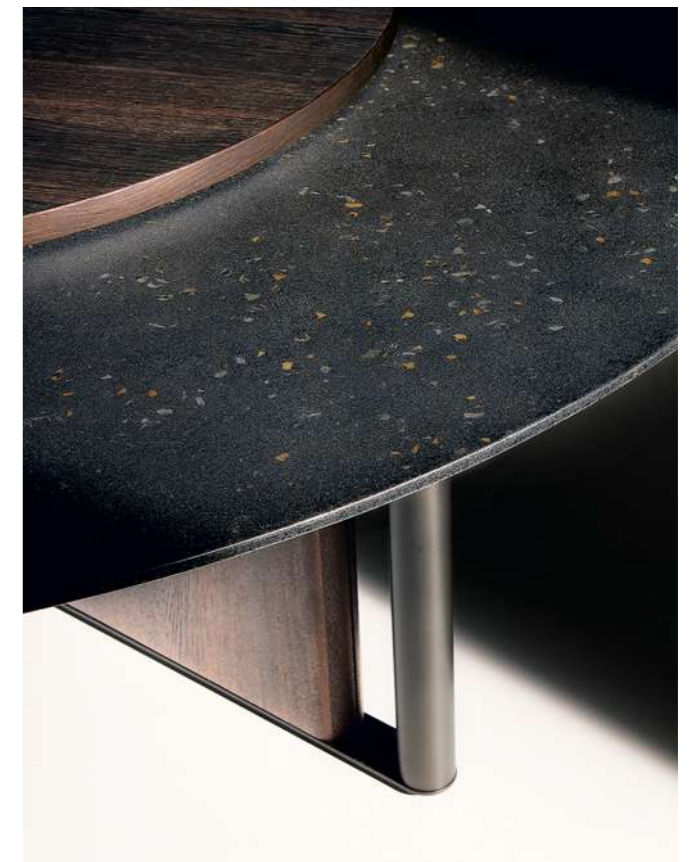
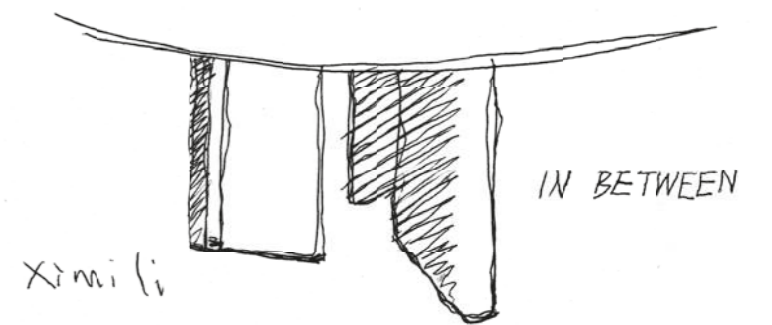
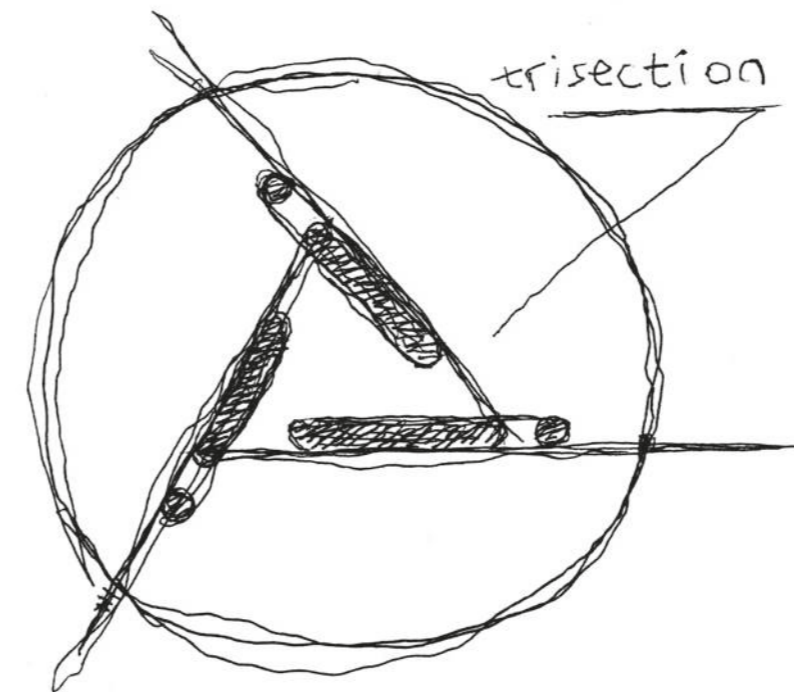

**IT** Invito sussurrato a concedersi un momento di relax. In equilibrio tra stile classico e contemporaneo, la personalità della lounge chair Claire si rivela nel contrasto tra proporzioni esili e generose che ne caratterizzano l'estetica sinuosa e delicata.

**EN** A sweet invitation to relax. In fine balance between classic and contemporary, the personality of Claire lounge chair is revealed in the contrast between slender and generous proportions that characterise its sinuous and delicate aesthetic.

# CLAIRE Armchair →



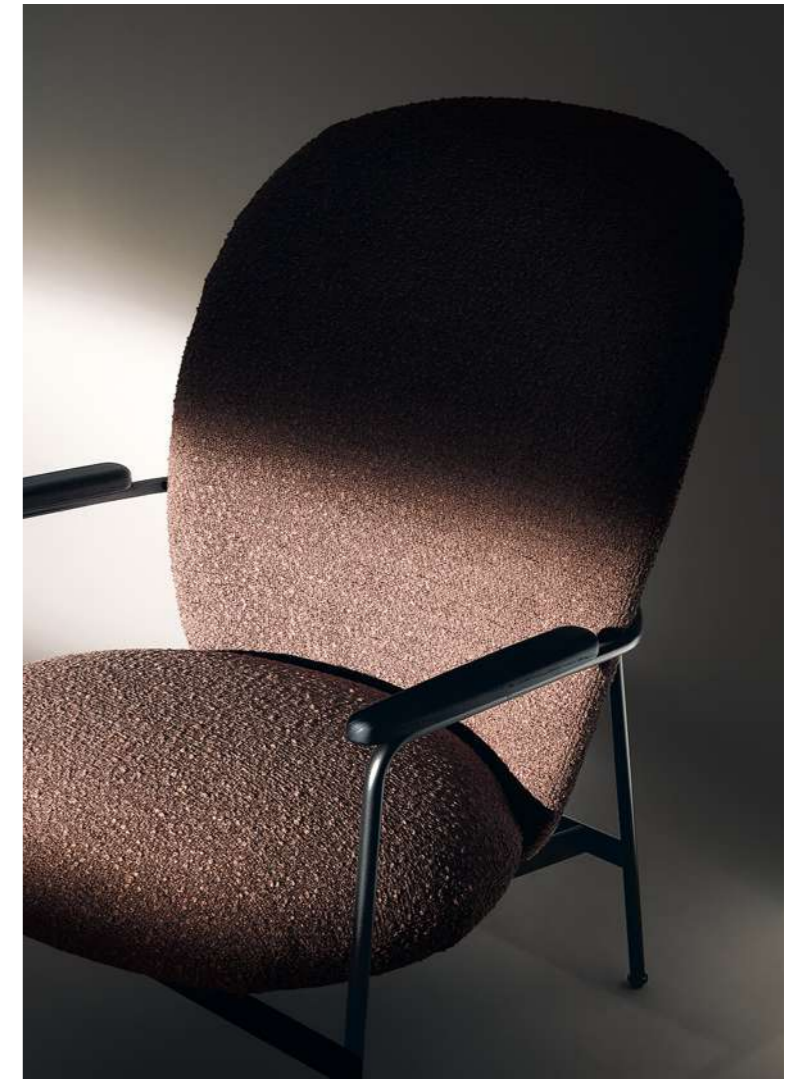

**IT** La lounge chair Claire è visivamente definita dallo schienale alto e dalla forma arrotondata, mentre la minimale struttura in metallo che sostiene l'imbottitura è impreziosita da braccioli in legno massello che aggiungono una rassicurante tattilità all'intera poltrona.

**EN** Claire lounge chair is visually defined by the high backrest and rounded shape, while the minimal metal structure that supports the padding is embellished with solid wood armrests adding a reassuring tactility to the whole armchair.



# FINISHINGS Proposals

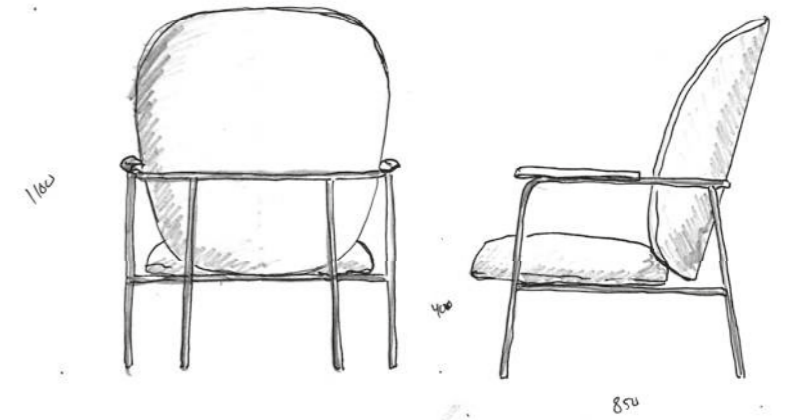
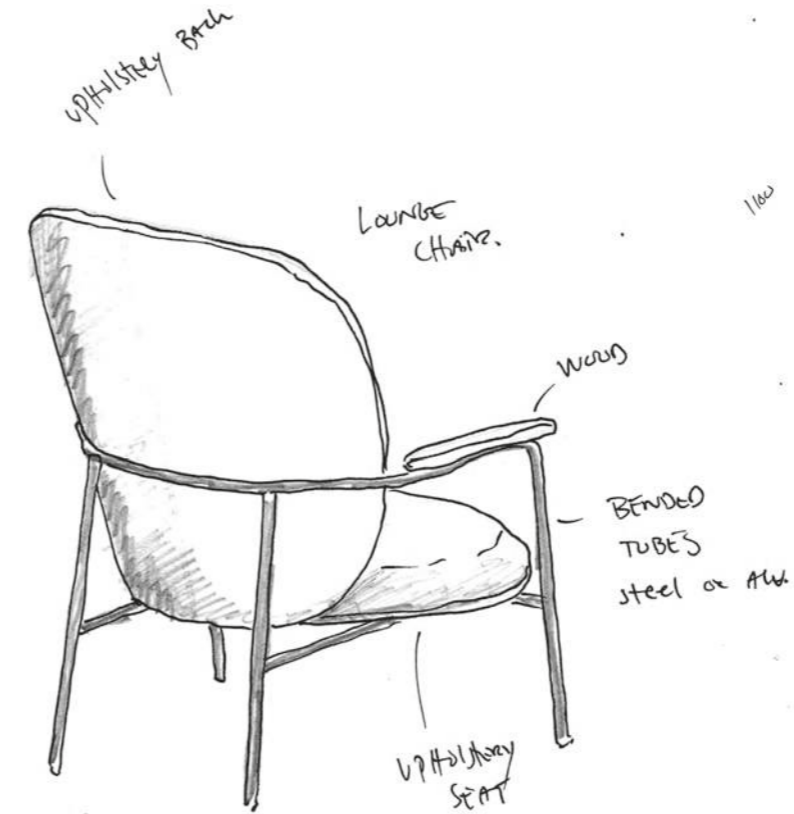

STRUTTURA  
STRUCTURE



NERO-M440

TABIT-TDE865



TABIT-TDE862



IT Quintessenza della discrezione di Lema e del tratto rigoroso di Piero Lissoni, la collezione Ombra nasce da una profonda attività di ricerca su forme e materiali. Composta da poltroncina, sedia e sgabello, si distingue per la grande raffinatezza stilistica.

EN Quintessence of Lema's discreet design and Piero Lissoni's rigorous trait, the Ombra collection was born from a profound research on shapes and materials. The collection is composed by an armchair, chair and stool, they stand out for their great stylistic refinement.

# OMBRA Stool →

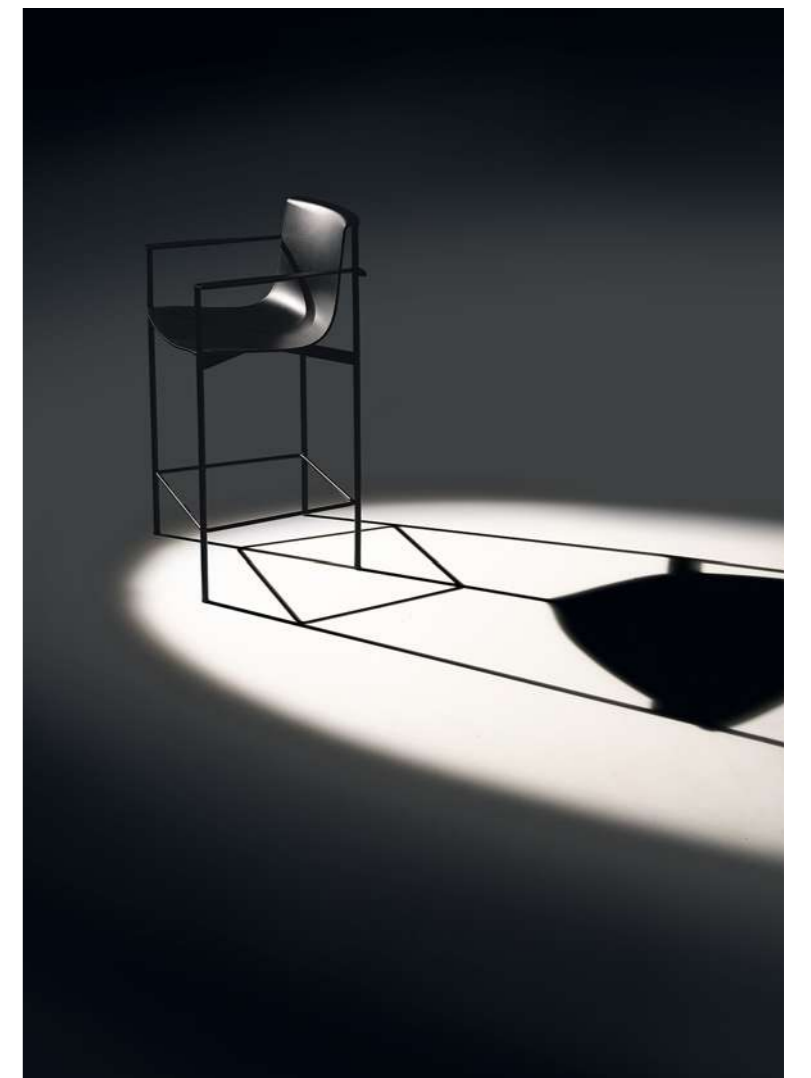



**IT** La collezione Ombra è caratterizzata da una struttura in metallo, leggera alla vista ma solida nella funzione, che sostiene la scocca che senza continuità accoglie sedute e schienale. Formata da un foglio stampato in polipropilene rigido, minimo nello spessore, la scocca dei complementi Ombra è proposta anche con rivestimento in pelle con leggerissima imbottitura.

**EN** The Ombra collection is characterised by a metal structure, light to the eye but solid in function, which supports the shell that seamlessly accommodates seats and backrest. Formed from a rigid polypropylene sheet, minimal in thickness, the shell of Ombra is also available in leather with very light padding.



SEDUTA  
SITTING



POLIPROPILENE  
NERO



POLIPROPILENE  
GRIGIO



BIANCO RAL  
9003



PELLE BASIC  
PB7150



PELLE BASIC  
PB7280

STRUTTURA  
STRUCTURE



NERO-M440



GRIGIO-M470



# FINISHINGS Proposals



**IT** Semplicità che dà voce ad emozioni primordiali. Il tavolino Francis ha una silhouette intrigante che abita gli spazi con disinvoltura. Le forme monolitiche che compongono la base e il piano del tavolino, evocano i camini delle fate in Cappadocia, una regione esotica in cui l'elemento naturale è protagonista.

**EN** Simplicity that gives voice to emotions. The Francis coffee table has an intriguing silhouette that fits into any space with ease. The monolithic shape that makes up the base and the top of the table evoke the fairy chimneys in Cappadocia, an exotic region where nature is protagonist.

# FRANCIS Coffee table →





**IT** I tavolini Francis svelano la propria anima nella durezza della materia che li compone, declinata in un equilibrio di forme curvilinee semplici, che donano un carattere informale all'intera figura. Il punto d'incontro tra le geometrie del piano e della base, dona ai tavolini il giusto compromesso tra solidità e naturalezza.

**EN** Francis coffee tables reveal their soul in the hardness of the material that composes them, declined in a balance of simple curvilinear shapes, which give an informal character to the whole figure. The meeting point between the geometries of the top and the base gives the tables the right compromise between solidity and nature.



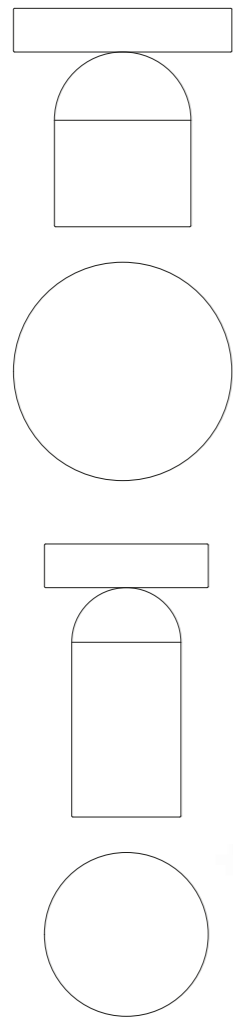

TUTTI I FORMATI  
ALL FORMATS

H. 395 mm  
Ø 400 mm

H. 500 mm  
Ø 300 mm



# FINISHINGS Proposals

→

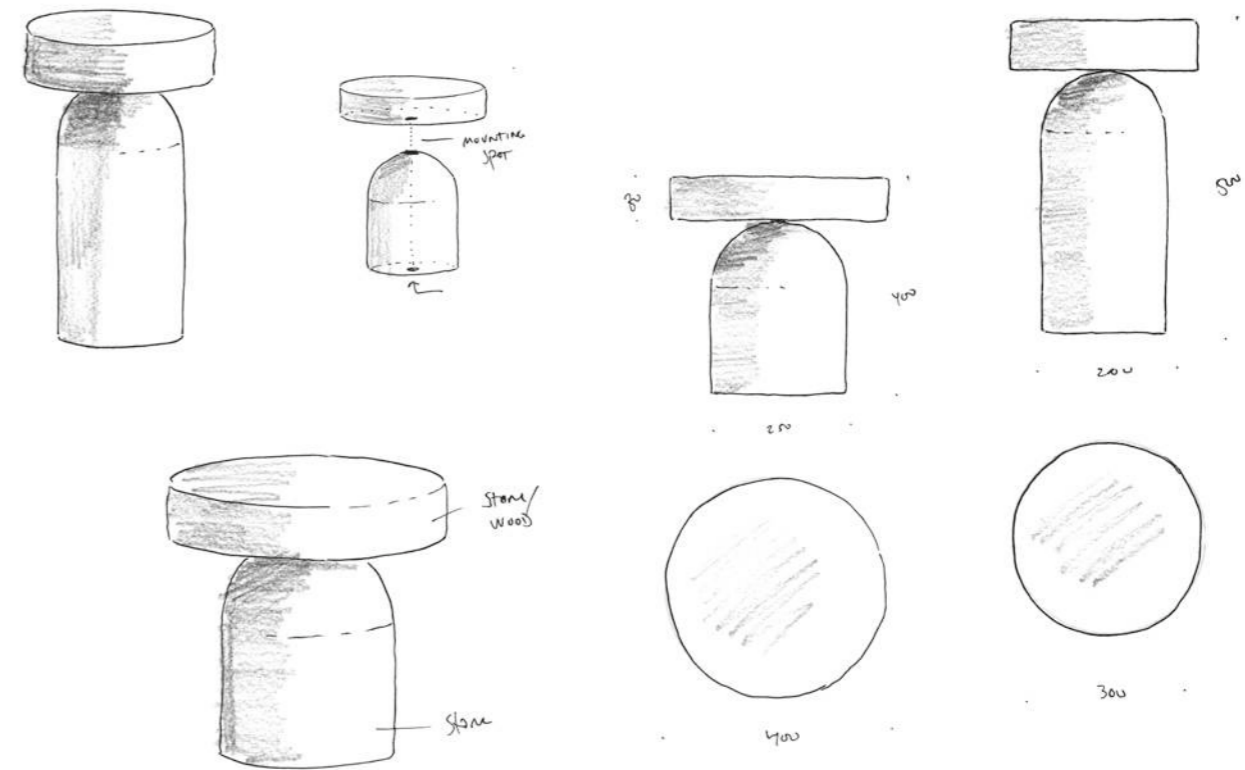

MARMO BIANCO CARRARA



FRASSINO TINTO  
ROVERE TERMOTRATTATO



TRAVERTINO

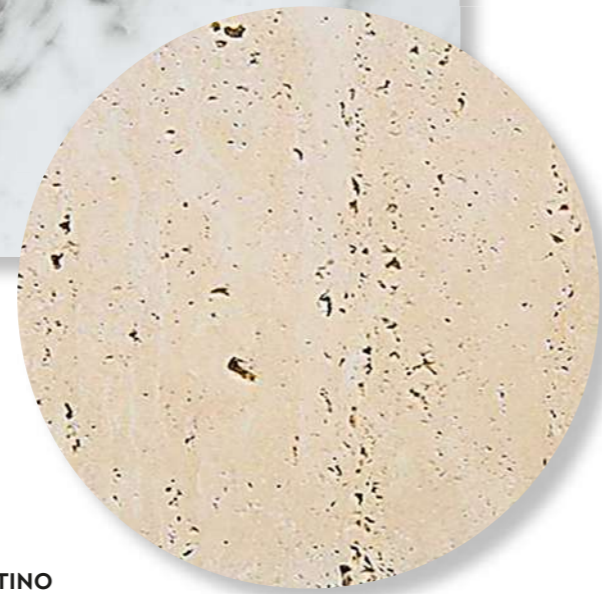

**IT** Sinfonia di materiali naturali, stilemi danesi e fascino made in Italy. Fred è una seduta dalle linee classiche in legno, emblema della capacità dei maestri ebanisti di Lema. La sedia da pranzo si ispira ai mobili della metà del secolo e al fine stile italiano rappresentato attraverso una prospettiva votata all'essenzialità, tipica dell'estetica danese.

**EN** Symphony of natural materials, Danish stylistic features and made in Italy charm. Fred is a chair with classic lines in wood, emblem of Lema's master cabinetmakers' skill. The dining chair is inspired by mid-century furniture and fine Italian design represented through a perspective devoted to essentiality, typical of Danish aesthetics.

# FRED Chair →







**IT** Lo schienale in legno massello della sedia da pranzo Fred è perfettamente arrotondato in modo da sostenere con dolcezza la seduta in qualsiasi posizione. Legno massello, comfort imbottito, leggerezza e linee delicate: giunti in osso di legno e infissi in metallo bronzato, attirano l'attenzione sui dettagli e sulle qualità intrinseche dei materiali.

**EN** The solid wood back of the Fred dining chair is perfectly rounded in order to gently support the seat in any position. Solid wood, padded comfort, lightness and delicate lines: joints in wooden bone and frames in bronzed metal drawing attention to the details and intrinsic qualities of the materials.



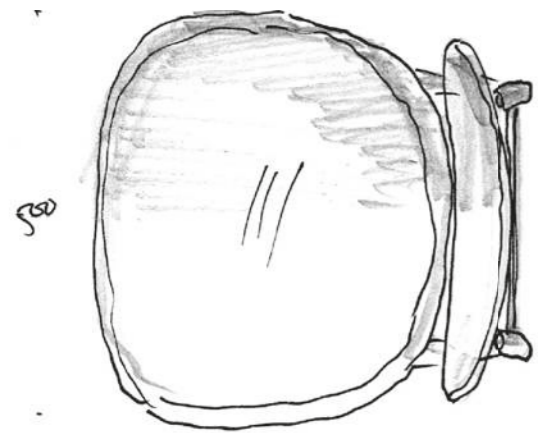
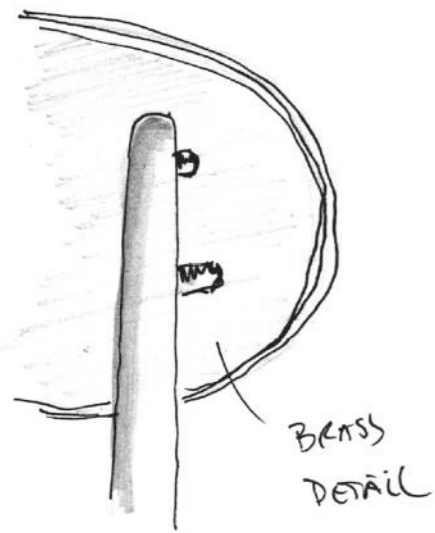

TOP CERVO

FRASSINO TINTO  
ROVERE TERMOTRATTATO



FRASSINO  
NATURALE



# FINISHINGS Proposals

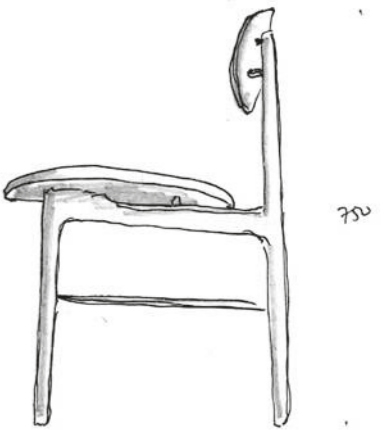
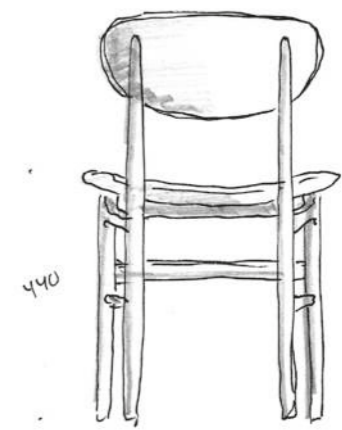
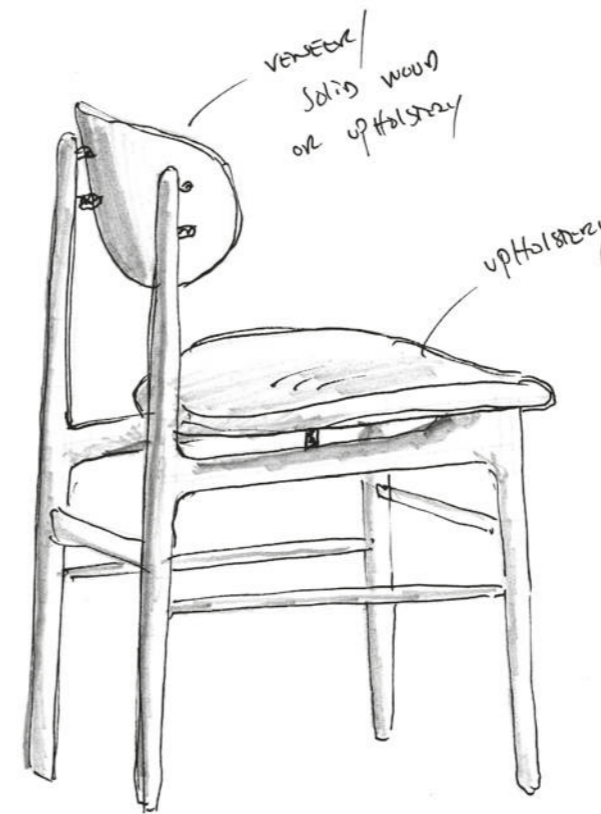

Dinner chair  
version 02



IT Geometrie pure giocano liberamente dando vita a Dolmen: un sistema di tavolini caratterizzato da forme ed altezze diverse che animano la zona giorno con brio, trovando la sua massima espressione in composizioni multiple.

EN Pure geometries interact giving life to Dolmen: a system of tables characterised by different shapes and heights animating the living area, they find its maximum expression when used in multiple compositions.

# DOLMEN Small tables

→

COMPOSIZIONI E FORMATI  
COMPOSITIONS AND FORMATS

800 x 800 mm  
800 x 1600 mm  
Ø 960 mm  
Ø 1200 mm

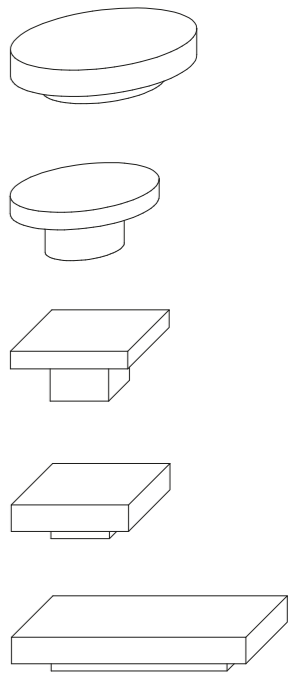



**IT** Dolmen è una famiglia di tavolini che si caratterizza per i piani dalle diverse forme geometriche pure – rettangolari, quadrate o rotonde – da comporre liberamente in un gioco di incastri. Pensati per la zona living al servizio dei divani, i tavolini hanno una struttura in metallo verniciato bronzo, mentre i top sono proposti in laccato opaco e legno.

**EN** Dolmen is a family of coffee tables characterised by tops with different pure geometric shapes – rectangular, square or round – to be freely composed. Designed for the living area next to sofas, the tables have a bronze painted metal structure, while the tops are available in matt lacquer and wood.

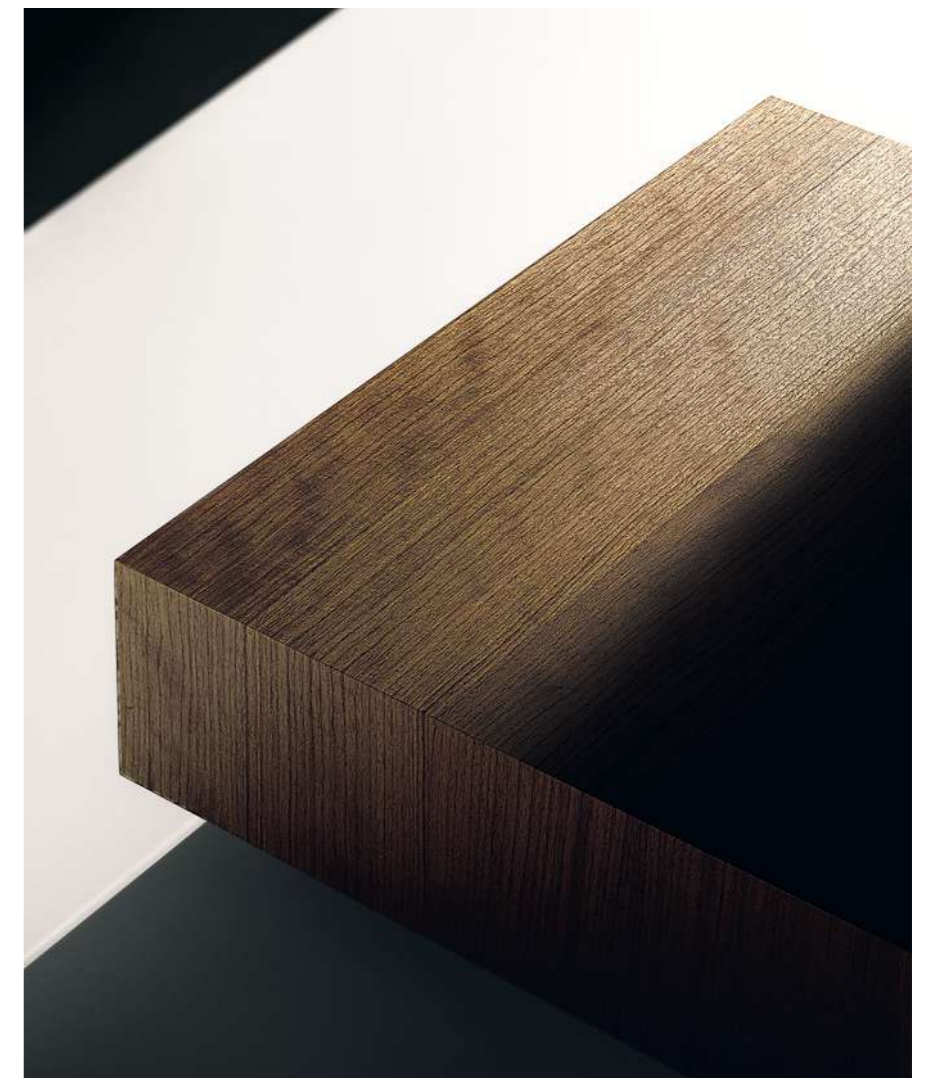
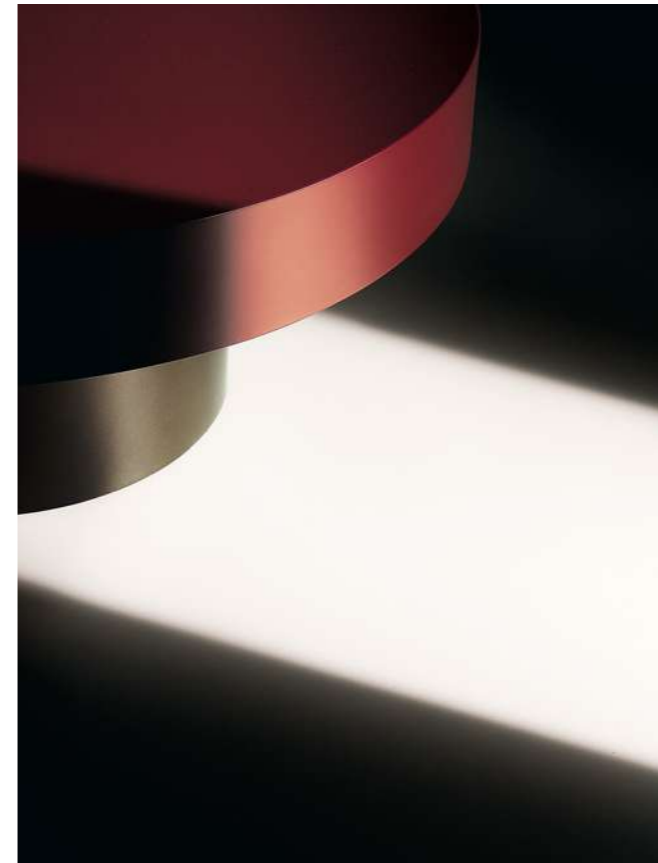

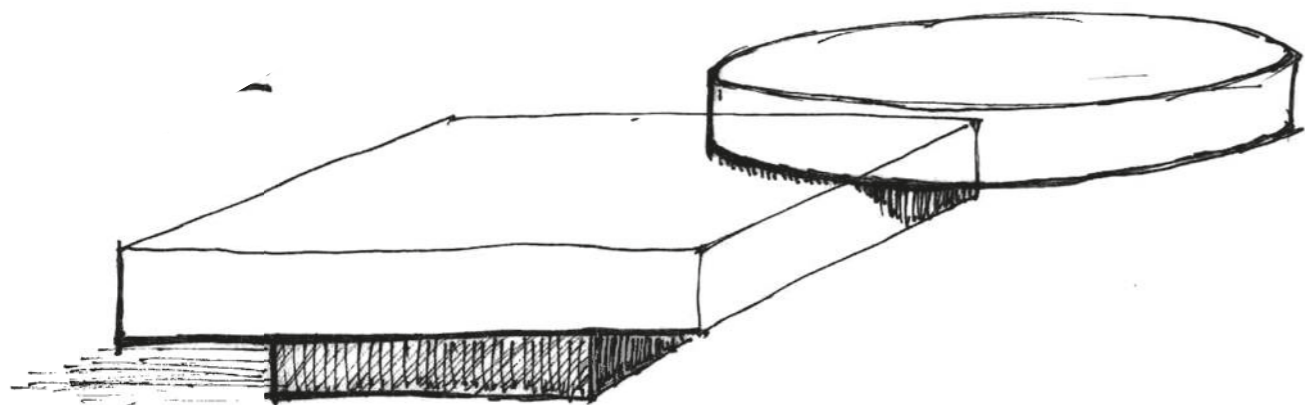
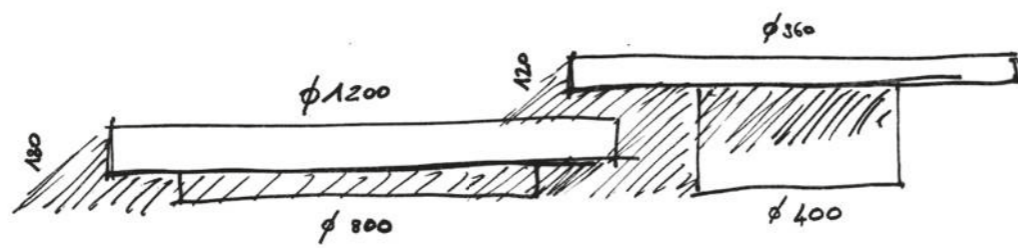

# FINISHINGS Proposals

→



**IT** Dal più contemporaneo al più classico, il divano a terra Niveaux si definisce nella sua elevata versatilità compositiva, grazie ai diversi moduli di seduta imbottiti quadrati, rettangolari e asimmetrici. Abbinati a tavolini d'appoggio, si uniscono ad una serie di schienali liberi o fissi e cuscini, oltre alle numerose proposte di combinazioni di materiali e texture ton sur ton.

**EN** From the most contemporary to the most classic, the Niveaux free-standing sofa is defined by its high compositional versatility, thanks to the different square, rectangular and asymmetrical upholstered seating modules. Combined with side tables, they are composed by a series of moveable or fixed backrests and cushions, in addition to the numerous proposals for combinations of tone-on-tone fabrics and textures.

## NIVEAUX Modular sofas





**IT** La nuova proposta firmata da Federica Biasi è un divano a terra modulare, una proposta di seduta versatile e adatta ad inserirsi con facilità in differenti ambienti. Nella versione con schienali liberi così come in quella con schienali fissi, le molteplici facce di Niveaux creano composizioni in grado di esprimere la personalità giovane e fresca del divano, capace di abitare la zona living con disinvoltura.

**EN** The new proposal designed by Federica Biasi is a modular floor sofa, a versatile seating proposal suitable any space. In the version with moveable backs as well as in the version with fixed backs, the multiple soul of Niveaux creates compositions capable of expressing the fresh personality of the sofa, capable of fitting into the living area with ease.



DIVERSE COMPOSIZIONI  
DIFFERENT COMPOSITIONS

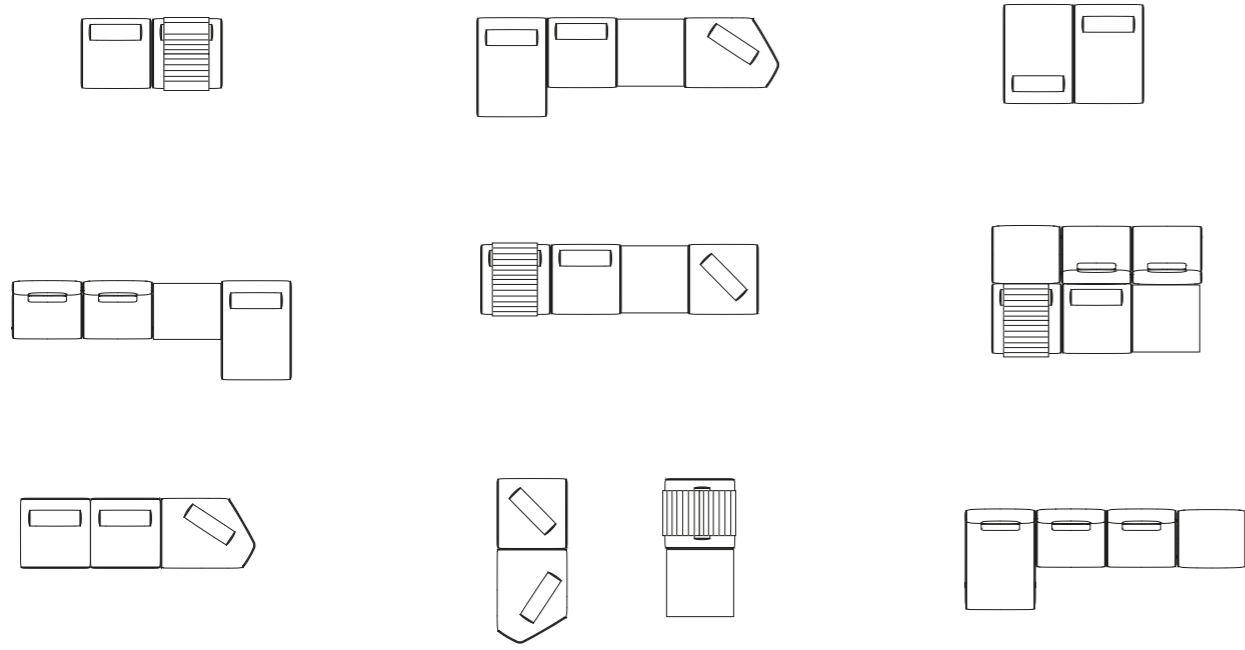



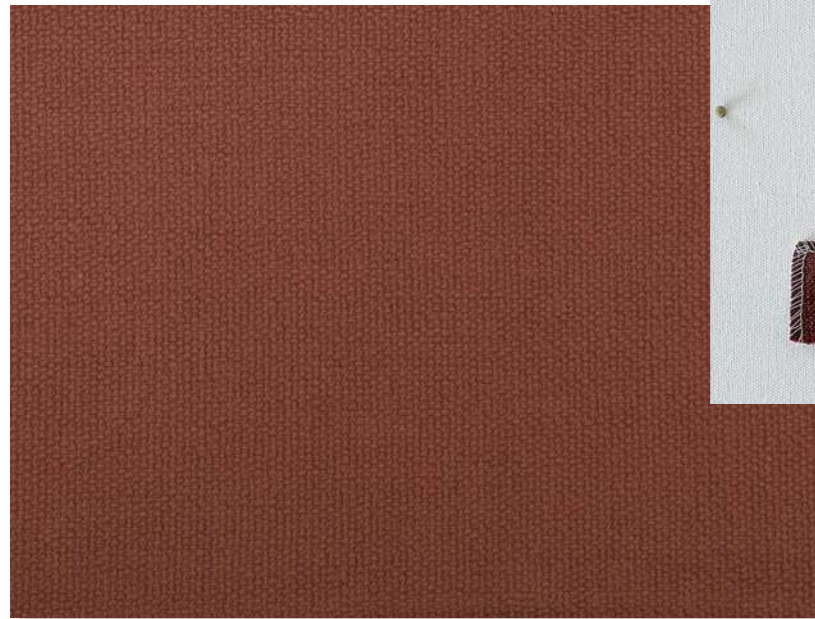

NAMID TDE284

# FINISHINGS Proposals →

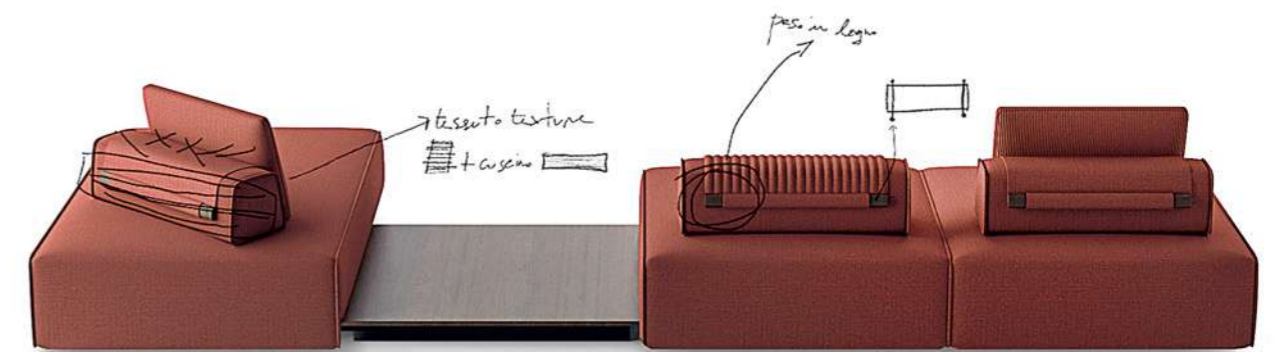

NAMID TDE280



LCL GRANATA 238



**IT** Linee classiche e animo tradizionale. Glee fa della versatilità il suo tratto distintivo, aggiungendo un tocco di leggerezza e contemporaneità agli ambienti.

**EN** Classic lines and traditional soul. Glee makes versatility its distinctive trait, adding a touch of lightness and contemporary style to the home.

# GLEE Sofa →



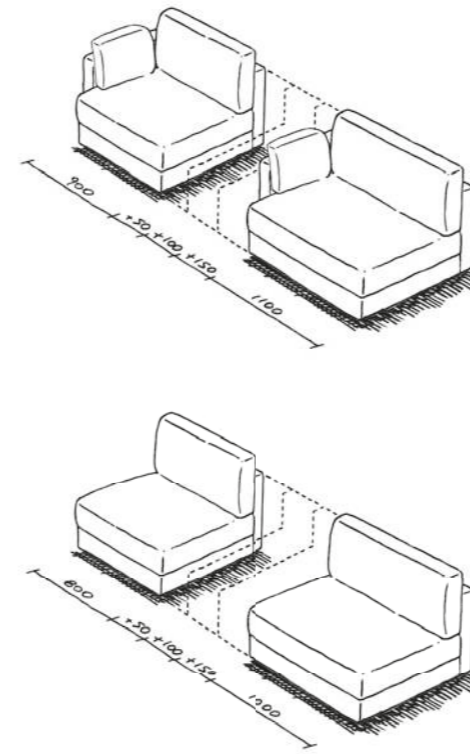



IT La cura sartoriale del dettaglio tipica del made in Italy e l'alta personalizzazione, fil rouge di ogni prodotto Lema, si esalta nell'Armadio al Centimetro così come nella novità Glee: è possibile scegliere la larghezza del divano modulare Glee con passo 5 cm tra la misura massima e la misura minima per adattarlo pienamente alle diverse esigenze funzionali, di spazio ed estetiche. La scelta ideale per un "comfort al centimetro".

EN The sartorial attention to detail typical of made in Italy and the customisation, fil rouge of each Lema design, is enhanced in the Armadio al Centimetro as well as in the Glee news: it is possible to choose the width of the Glee modular sofa with 5 cm between the maximum size and the minimum size to fully adapt it to the different functional, space and aesthetic needs. The ideal choice for a "comfort al Centimetro".



**IT** Gioco di combinazioni tra forme rigide e morbide: il divano modulare Groovy racchiude l'essenza del relax in una struttura esile e slanciata, esprimendo il suo carattere sofisticato nei dettagli sartoriali. Come petali che si schiudono, i suoi braccioli si aprono lievemente verso l'esterno portando in risalto la morbida cuscinatura.

**EN** A combination of rigid and soft shapes: Groovy modular sofa invites you to relax in a slender structure, expressing its sophisticated character thanks to its tailored details. Like blossoming petals, the armrests open slightly towards the outside, highlighting the soft cushions.

# GROOVY Sofa →





**IT** Groovy è il perfetto interprete di una filosofia improntata alla convivialità, che trova nel comfort e nella modularità i suoi caratteri fondamentali. Sostenuto da piedini non a vista, la struttura rigida esterna del divano Groovy in pelle si unisce alla cuscineria, disponibile anche in tessuto, per creare diversi abbinamenti materici e cromatici.

**EN** Groovy is the perfect interpreter of a philosophy based on conviviality, which finds its fundamental characteristics in comfort. Supported by non-visible feet, the rigid external structure of Groovy sofa in leather is joined with the cushions, it also available in fabric, to create different fabric and chromatic combinations.

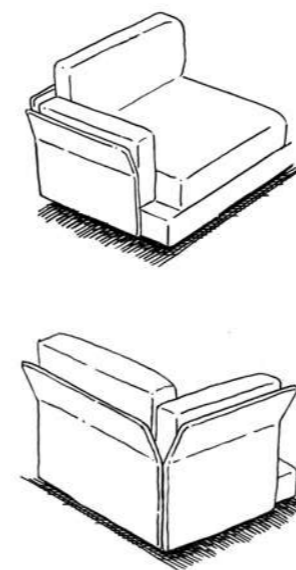

**IT** Linee sinuose delineano il profilo delicato di Ayra, sedia e poltroncina dal design morbido e avvolgente. Il suo tratto distintivo risiede nella forma dello schienale che scende rispetto alla seduta, creando un movimento inaspettato.

**EN** Sinuous lines outline the delicate profile of Ayra, a chair and armchair with a soft and enveloping design. Its distinctive features include the shape of the backrest connected to the seat, creating an unexpected movement.

# AYRA Chair →



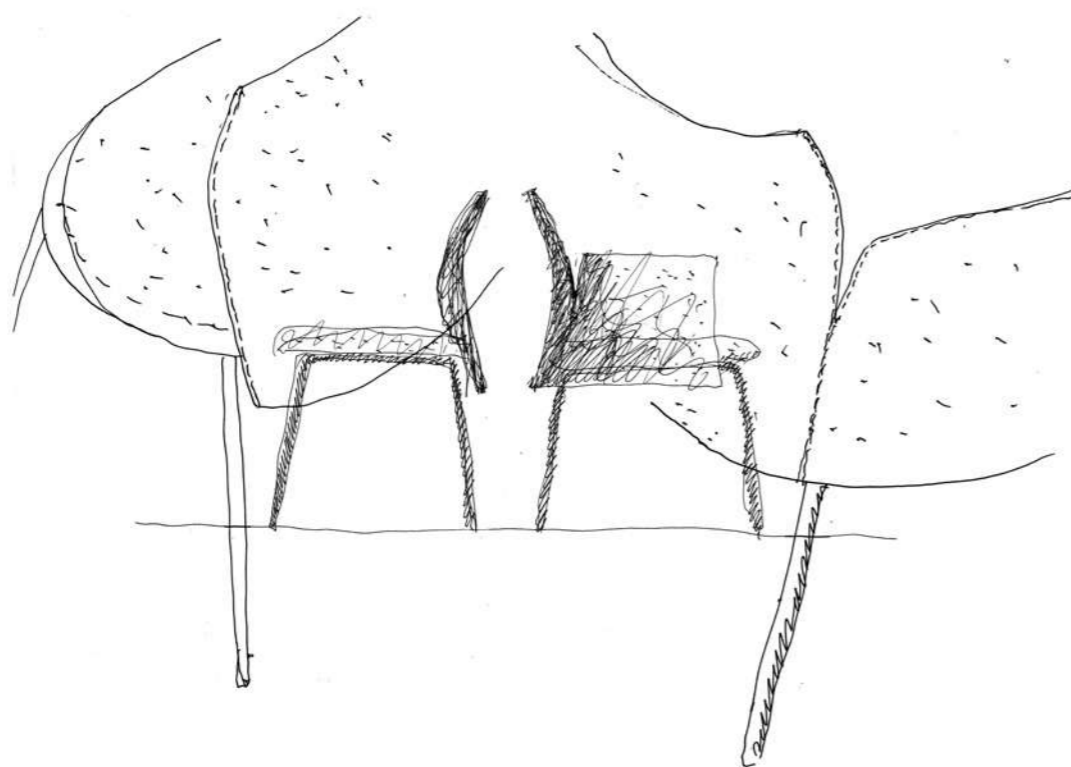

**IT** Rivestita in tessuto o in pelle, con gambe in metallo, Ayra è una proposta trasversale, per andare incontro alle diverse esigenze estetiche. Una seduta fortemente contemporanea nelle proporzioni, ideale intorno ad un importante tavolo da pranzo. La raffinatezza di Ayra è esaltata dalla curvatura del sedile e nei dettagli sartoriali, che le conferiscono una presenza delicata e armonica.

**EN** Upholstered in fabric or leather, with metal legs, Ayra is a transversal design, to meet different aesthetic needs. A highly contemporary seat in proportions, ideal around an imposing dining table. The refinement of Ayra is enhanced by the curvaceous seat and in its sartorial details, which give it a delicate and harmonious presence.





PROJECT LISSONI GRAPHX  
PHOTO THOMAS PAGANI  
TEXT R+W  
TRANSLATION LEMA  
REPRO+PRINT OGM, 2022

LEMA S.P.A.  
22040 ALZATE BRIANZA  
COMO — ITALIA  
STRADA STATALE BRIANTEA N° 2  
T. +39 031 630 990  
LEMAMOBILI.COM

关注LEMA微信公众号  
Follow LEMA WeChat account



公众号 ID : LemaOfficial

