

HIMALAYAN  

---

UNDYED

THE COLLECTION



Nodus Allover collection	5
Rugs in eco-friendly Himalayan wool	6
Bartoli Design for Nodus	16
Himalayan Undyed collection	18
Himalayan Undyed colors	72
Inspirations	74
Technical information	80



## NODUS ALLOVER COLLECTION

A collection of design rugs for all requirements. The collection focuses on design, quality and on innovation at an accessible price. The *allover* rug, as the name says, is made of patterns that cover the whole surface, made of shades, small images and tone on tone motifs, a feature that makes these rugs suitable for all environments and situations. A careful choice of raw materials always guarantees a high quality and long lasting product. Not only handknotted but also handtufted rugs, with flame resistant certification, for common spaces and contract businesses. A new challenge of Nodus: to share the beauty and the pleasure of design with as much persons as possible. A *democratic* collection meant not only for houses but also for public spaces.



## RUGS IN ECO-FRIENDLY HIMALAYAN WOOL



Himalayan Undyed is a collection of design rugs, hand-made in Nepal 100% Himalayan undyed wool pile knotted on a cotton warp. **The yarns are unbleached and undyed**, coming from Tibetan highland sheep whose natural color hues range from creamy white to brown to almost black.



Storage of natural wools

No synthetic hormones, synthetic pesticides and genetic engineering are involved in the process to produce Himalayan Undyed wool and rugs.

Reared by nomads and only surviving at the high altitudes of the Tibet and Nepal Plateau, reaching 5100 meters above the sea level, this breed produces a distinctive thick fleece that has a long staple, high tensile strength and is rich in lanoline and natural wool wax. **Rugs made with the characteristically hard-wearing and vibrant Tibetan wool mature beautifully over time.**

Tibetan sheep are kept freely and graze in vast highlands on bushes like sedge, carex and stipa; nomads move from place to place, never exceeding the natural carrying capacity of the land on which they raise their flocks.

Flocks are never sprayed nor dipped, as is commonly practiced in conventional wool production systems. No synthetic hormones, synthetic pesticides and genetic engineering are involved in the process to produce Himalayan Undyed wool and rugs.



Himalayan lands

Wool is a natural fiber and a renewable resource that is non-allergenic. The very few people with wool allergies are commonly reacting to the chemicals used to process the wool rather than to the wool itself. Actually most conventional woollen products are no longer “natural”, having been treated by several processes (alkaline baths to remove dirt and grease, acid baths to remove vegetable matter, anti-shrink for machine washing, bleaching, dyeing, moth proofing, and possibly flame proofing). **Nothing is added to Nodus Himalayan Undyed wool. Being rich in lanoline, it is naturally very soft so it does not need conditioners.** There are no flame retardants, as wool is naturally self-extinguishing, and no dyes as all Himalayan Undyed rugs are in the natural colors of the Tibetan bred sheep.



Knotting Wangden rug



Spinning by hand on traditional wheels





Removing the rug from the loom at the end of the knotting process

Himalayan Undyed wool is hand-processed without using chemicals, environmental pollutants and substances that pose a health or safety hazard for workers or consumers. After being collected from nomads, the wool is sorted by hand to pick out foreign materials and other form of dirt - while conventional wool is "carbonized" where vegetable matter is burned out in an acid bath - then it is washed with hot water to remove exceeding wax, but still leaving enough lanoline to create a soft product that retains more of the wool's natural characteristics. In the same time wool is classified by natural colors, then teased and spun by hand with traditional teasing tools and spinning wheels (when the wheel becomes harder, soybean oil is used).



Taking care of little differences among the knots and putting them into the right place of the warp



Brushing the pile to clean and to keep it softer

Himalayan Undyed wool is hand-processed without using chemicals, environmental pollutants and substances that pose a health or safety hazard for workers or consumers.

Different thicknesses of yarns can be spun for weaving rugs: skilled craftsmen hand-knot the woollen yarn into a pure indian cotton warp fixed on a loom, with the help of an iron rod. When the entire carpet is finally woven, it is scissor-clipped to give a lively look and soft touch, then it is manually washed with water and liquid soap based on Sapindus (a plant used for the production of natural soaps) and stretched onto a frame after drying, to regain its specific dimensions.



Removing water before drying under the sun





Washing the rug with Sapindus berries



Rugs drying process under the sun

The carpet trimming and look are checked and a carved pattern may be carved; possible remaining dirt is plucked. The yarn waste of the weaving, trimming and carving processes is collected for the recycle people who come weekly and use it for blankets, cushions and dunlops. Himalayan Undyed helps to keep alive a traditional eco-friendly management and hand weaving process and provides the chance to enjoy the beauty of real natural wool.

**Himalayan Undyed helps to keep alive a traditional eco-friendly management and hand weaving process and provides the chance to enjoy the beauty of real natural wool.**



Finishing with scissors to make perfect edges of the carved pattern

## BARTOLI DESIGN FOR NODUS RUG



### STUDIO ASSOCIATO DI ARCHITETTURA E DESIGN

Bartoli Design is a team formed by Carlo, Paolo and Anna Bartoli, who today continue the project that was begun by Carlo Bartoli in 1960 and has been made concrete through numerous collaborations with leading companies in the field of furnishing - including *Arflex*, *Bonaldo*, *Confalonieri*, *Colombo Design*, *Enrico Pellizzoni*, *Fiam*, *International Office Concept*, *Jesse*, *Kartell*, *Kristalia*, *Laurameroni Design Collection*, *Lualdi Porte*, *Matteograssi*, *Move*, *Nodus Rug*, *Rossi di Albizzate*, *Segis*, *Skipper*, *Steelcase*, *Tisettanta* and *Ycami*. The studio's research is dedicated to poetics based upon essentiality and balance: both in the initial concepts for product and communication strategies as well as their development, Bartoli's work embraces the complete spectrum of design

services. Bartoli Design also develops projects in architecture, urban design, furniture and interior design. In 2008 they received the *XXI Compasso d'Oro ADI award* for the *R606Uno* chair designed for *Segis* along with *Fauciglietti Engineering*. The *Tube Sofa* for *Rossi di Albizzate* won the *IF Award for Good Industrial Design* and was selected to appear on a series of Italian postage stamps entitled "*Italian Design for a New Domestic Landscape*". Carlo Bartoli has exhibited his work in Italy and abroad: at the *Triennale Design Museum* in Milan, at the *Victoria and Albert Museum* in London, at the *Stadt Museum* in Cologne as well as in New York, Prague, Hong Kong, Athens, and Buenos Aires. The *Gaia armchair* he designed for *Arflex* is included in the permanent design collections at

the *MOMA* in New York and the *Triennale Design Museum* in Milan. The *4875 chair* designed for *Kartell* is on display as part of the design collection at the *Pompidou Centre*, the *National Museum of Modern Art*, in Paris. The stacking armchair *Breeze*, designed for *Segis* - was the winner of the *I.D. Design Distinction Award*, *Apex Product Design Award*, *Red Dot* and *IF Award for Good Industrial Design* - and appears on an Italian postage stamp in the "*Masters of Italian design*" collection. The *Sol* table, designed by Bartoli Design for *Bonaldo*, received the "*2010 GOOD DESIGN Award*".



Our effort to create a new rug collection made of Himalayan wool is focused on the exaltation of the natural wool feature of Tibetan bred sheep.

These wool has a range of nine very tonal natural shades. Sometimes the change is extremely slight.

Undyed Himalayan wool has a kind of rustic look, but it is not rough, on the contrary, it is soft and elastic and the yarn has a natural movement.

We respected the peculiarity of the Tibetan manufacture: big knots, simple manufacturing, thinking of details that would enhance the characteristics of this rich wool.



Himalayan Undyed collection

**LHOTSE** 20

**ANNAPURNA** 32

**TERAI** 44

**WANGDEN** 58





Collection

# LHOTSE





Lhotse 1 detail, wool color 01



Lhotse 1, 200x300cm, wool color 01











Lhotse 2 details, wool color 07





COLLECTION **LHOTSE**

This project uses the Tibetan knot alternated to bouclé weaving, made with small rings and cut pile, on a drawing that interprets the geometry of fractures in a rocky ground. Wool is single colour and the pattern is created by lights and shadows, by the different heights between the bouclé and the cut knots. The irregular hexagonal or trapezoidal perimeter, inspired by the shapes of Tibetan rugs used as saddle cover, strengthens the internal pattern.

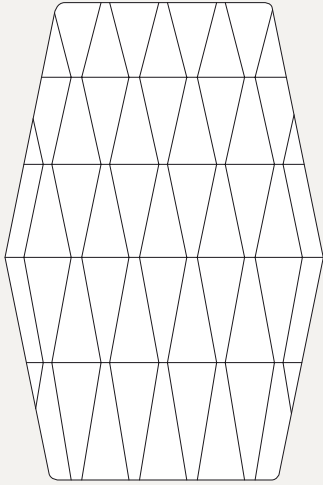

**LHOTSE 1**

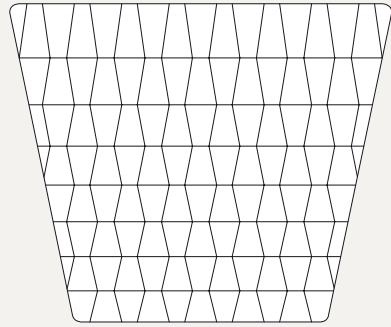

**LHOTSE 2**

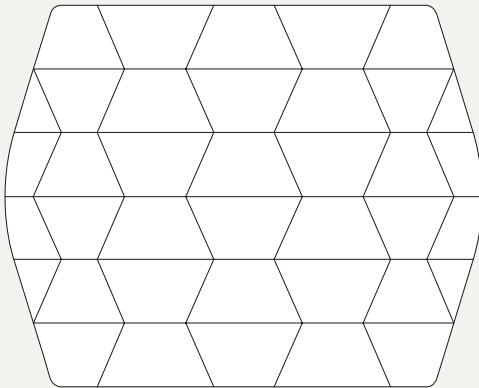

**LHOTSE 3**

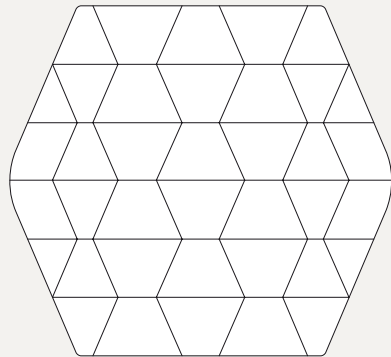

**LHOTSE 4**

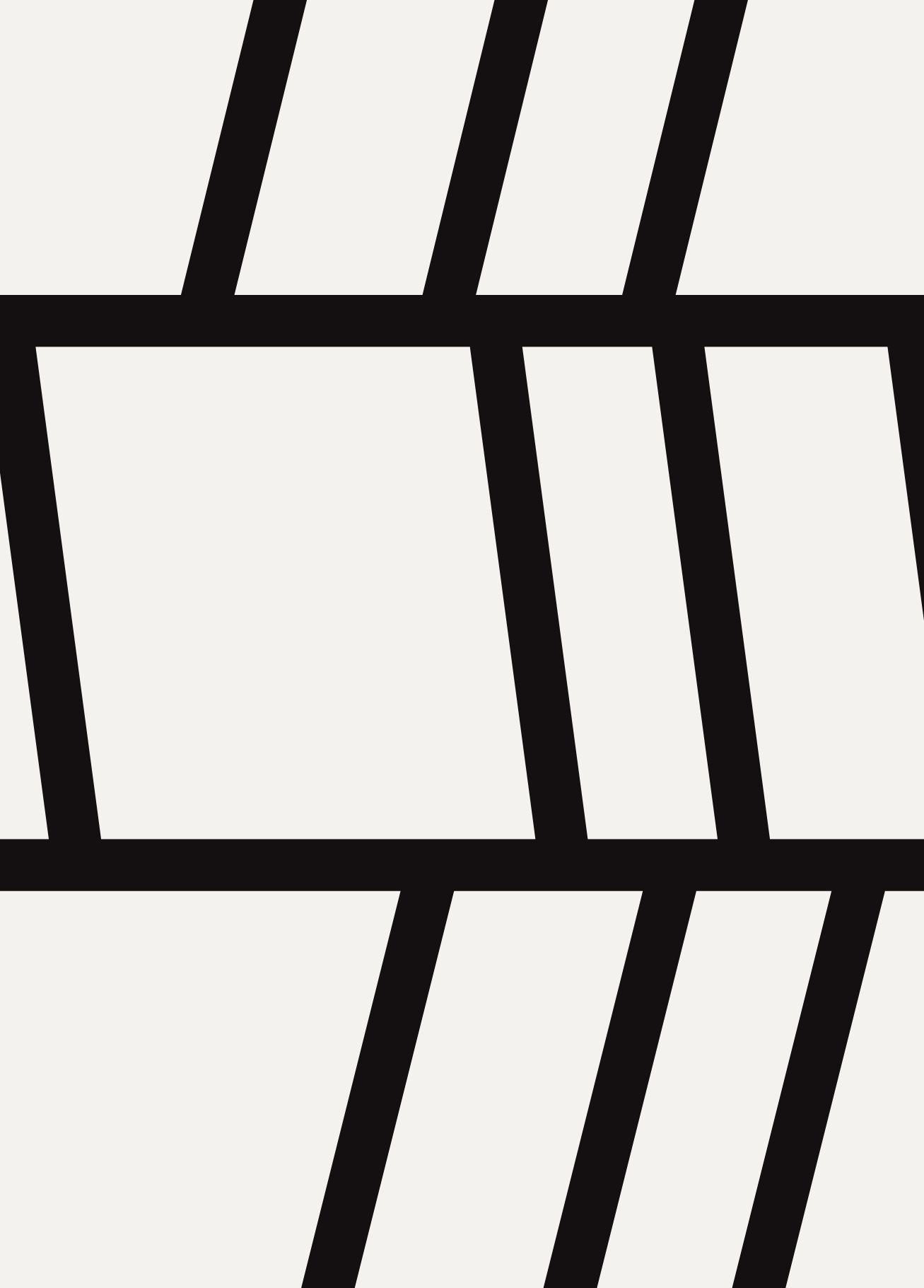





Collection

# ANNAPURNA









Annapurna 1, 200x300cm, color combination *soil* 1-3-5



Annapurna 1 details, color combination *soil* 1-3-5







Annapurna 2 runner, 100x330cm, color combination *mud 2-4-6*





COLLECTION **ANNAPURNA**

The pattern wants to show the delicate shades of the Himalayan wool; shaped as a parallelogram and divided by carvings, the “fractures of the rock”, may be in contrasting shades or in tonal colors. Single color variations are also available.

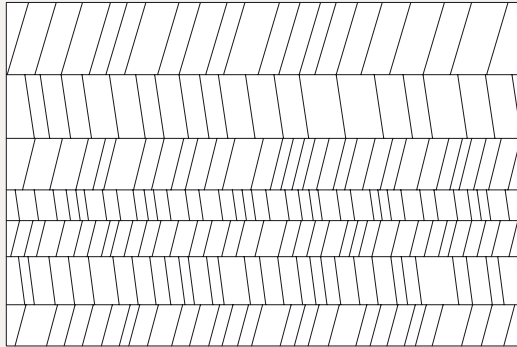

**ANNAPURNA 1**

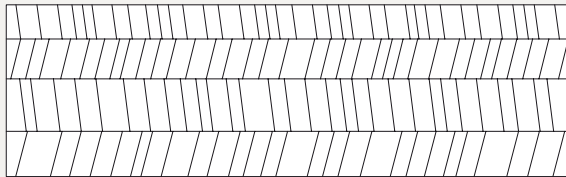

**ANNAPURNA 2 RUNNER**

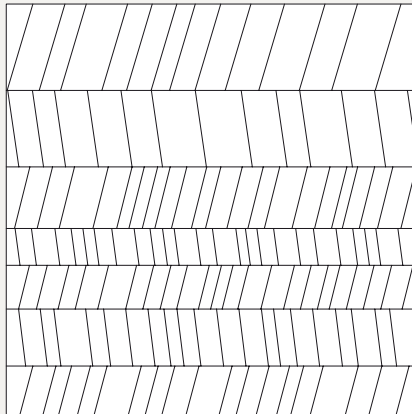

**ANNAPURNA 3**





Collection

**TERAI**



Terai 3 detail, wool color 09



Terai 3, 173x268cm, wool color 09

















Terai 2 detail, color wool 9



COLLECTION **TERAI**

Natural Himalayan wool has a color gradation, from ivory to intense brown, reminding the colors of earth. The animals live outside, or in a stable, on a ground that is earth, dust, rock or pasture and the fleece deeply absorbs also the pigments of the terrain. In this project we worked on the affinities of “undyed” wool with earth and its colors. The surface of the rug has also the texture of loose earth. The idea was inspired by the shadowplay created on cultivated and ploughed farmland. We will use one or two color shades in these rugs.



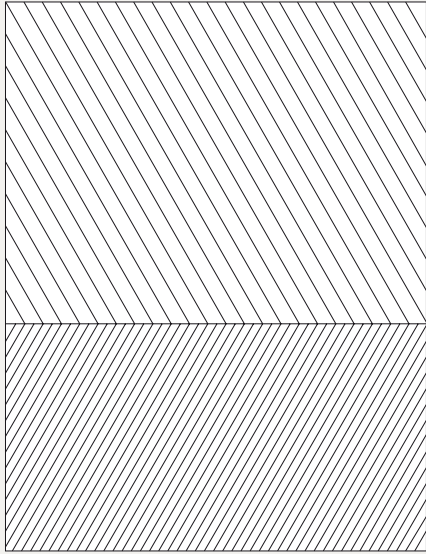

**TERAI 1**

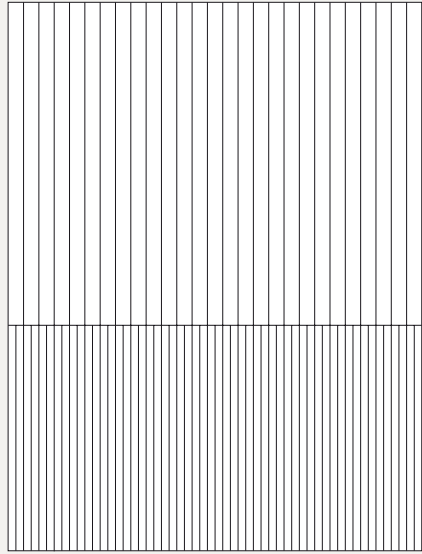

**TERAI 2**

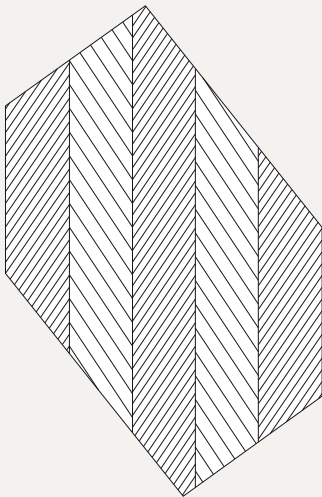

**TERAI 3**

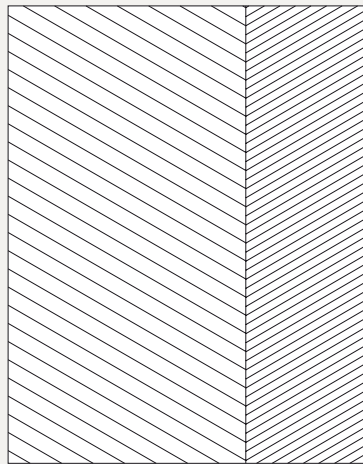

**TERAI 4**





Collection

# WANGDEN



Wangden 1, 250x250 cm, double color wool 8-2



Wangden 1 detail, double color wool 8-2







Wangden 2 runner, 125x335 cm, double color wool 4-8





Wangden 2 runner detail, double color wool 4-8



Wangden 1 detail, double color wool 8-2







Wangden 2 runner detail, double color wool 4-8

COLLECTION **WANGDEN**

Wangden rugs are sitting and meditation rugs, originally used in Tibetan monasteries, characterized by a soft touch and a thick fringe.

We are interpreting them to enhance the softness of wool.

We presented the original square form, thinking of them as sitting and relaxing places; to sit or lie on this rug gives the chance to appreciate its naturalness.

One can touch and feel the scent of wool. The square perimeter suggests a space to be shared.

The rectangular Wangdens for ancient benches inspired the runner.

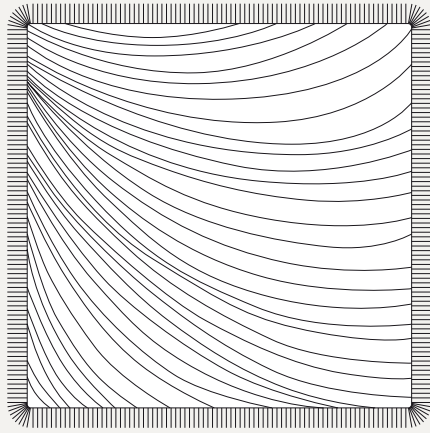

**WANGDEN 1**

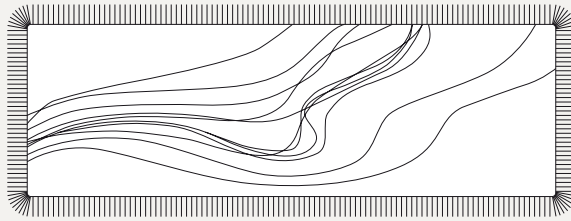

**WANGDEN 2 RUNNER**

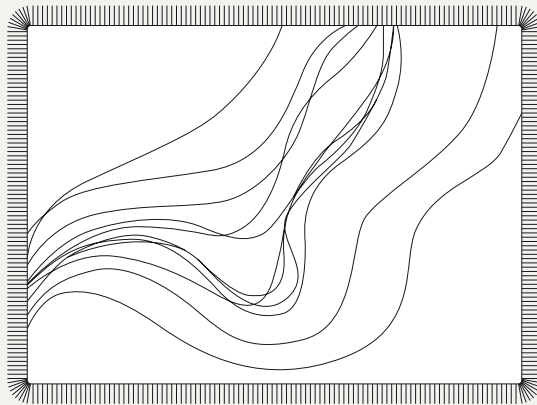

**WANGDEN 3**

## HIMALAYAN UNDYED COLORS



---

COLOR 01



---

COLOR 02



---

COLOR 03



---

COLOR 04



---

COLOR 05



---

COLOR 06



---

COLOR 07



---

COLOR 08



---

COLOR 09



SOIL



MUD



SAND



2 COLORS



## INSPIRATIONS

### LHOTSE

This project uses the Tibetan knot alternated to bouclé weaving, made with small rings and cut pile, on a drawing that interprets the geometry of fractures in a rocky ground. Wool is single color and the pattern is created by lights and shadows, by the different heights between the bouclé and the cut knots. The irregular hexagonal or trapezoidal perimeter, inspired by the shapes of Tibetan rugs used as saddle cover, strengthens the internal pattern.

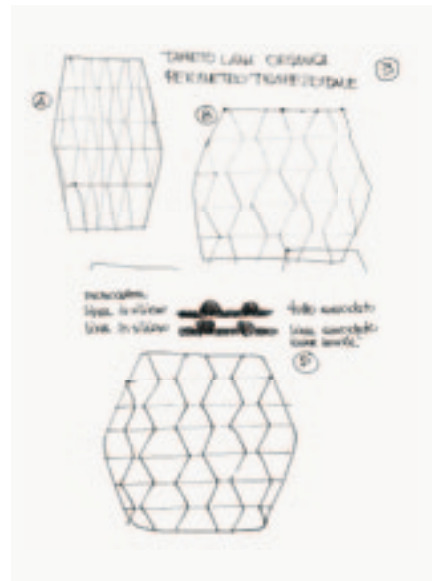

## ANNAPURNA

The design of Annapurna has been inspired by the arid land, mountains and rocks of the Himalayan area. Large and small rocks, fractured, crushed and pulverized are a constant of those extreme landscapes, represented in the rugs with an abstract pattern made of rhombuses, which uses the delicate color shades of the wool from tibetan highland sheep, from white to brown and almost black.

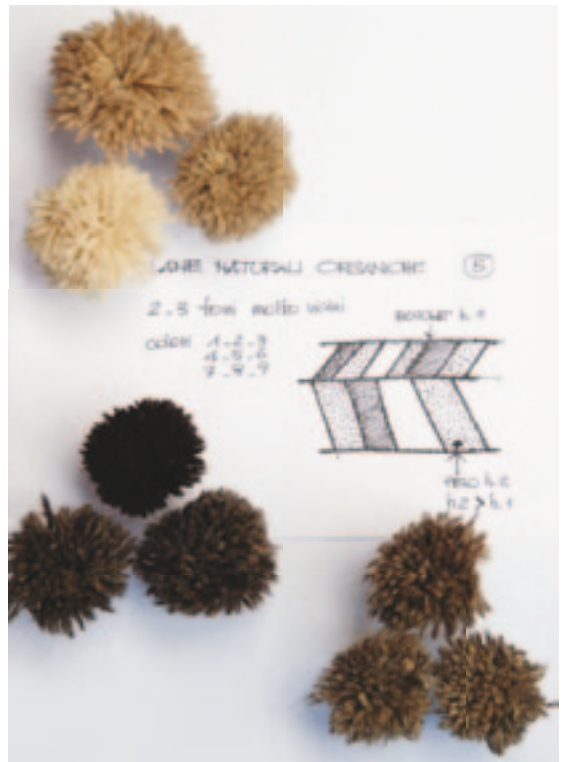

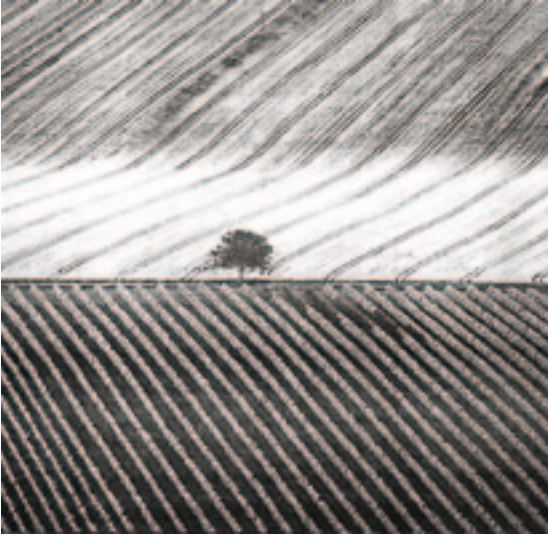

### TERAI

The design of Terai enhances the affinity of the undyed wool with the earth and its colors. The lines of cultivated, ploughed terrain and the shadows created by loose earth inspired the idea: Terai identifies the area of plain land and hills at the feet of the Himalaya, more fertile and cultivable than the areas at higher altitudes.

**WANGDEN**

Wangden were sitting and meditation rugs used by Buddhist monks, characterized by the fringe on all four sides – most probably the first kind of pile rug weaved in Tibet



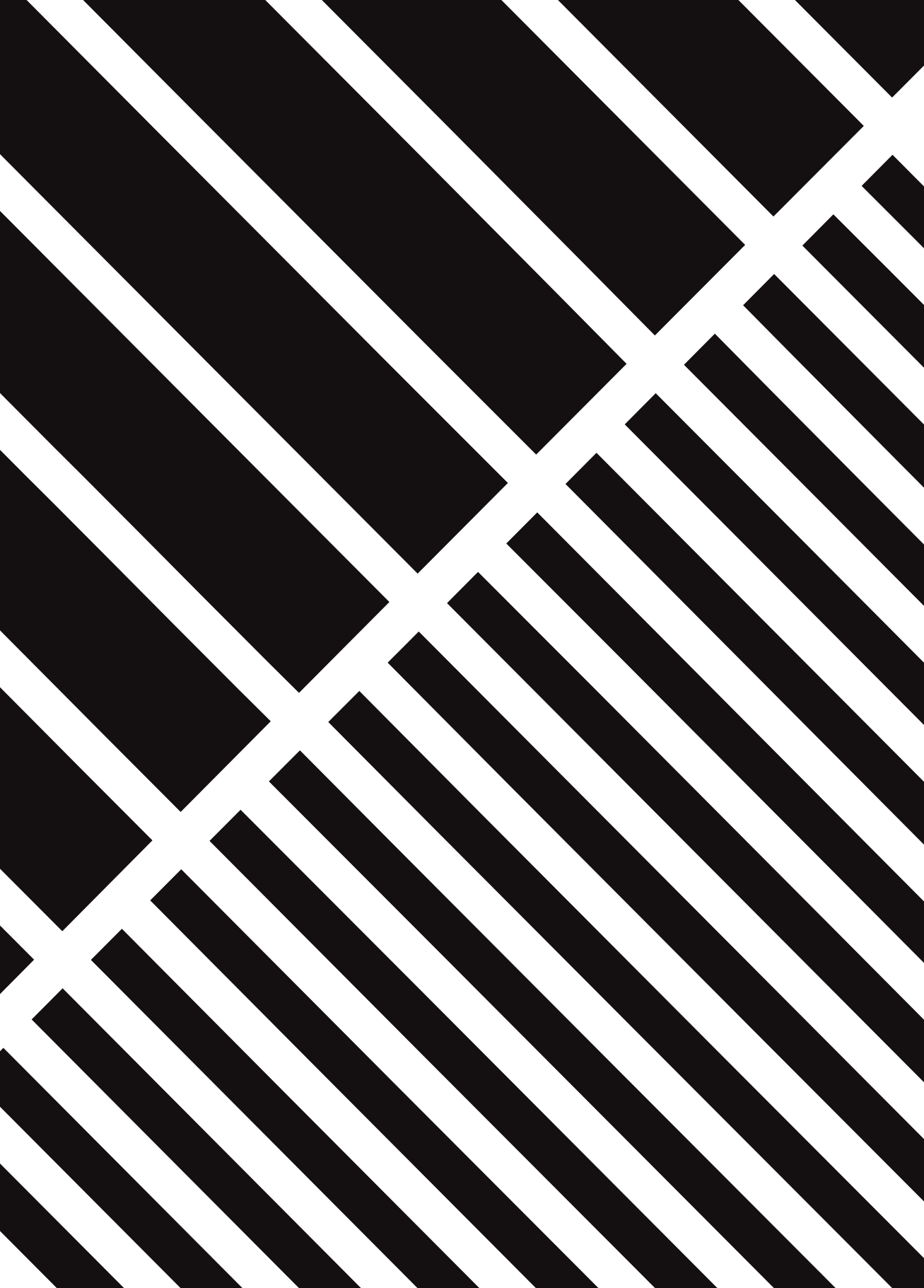

Nodus Himalayan Undyed is a completely natural product. Our care isn't precise and correct only regarding social matter, but also in ecological ones. In fact, we use only natural materials, and only hand crafted. Therefore there aren't effects on the environment, not in form of harmful discharges nor in any other form.

We don't neglect the rights of those who create our products, paying the highest attention in order that our manufactures do not use child labor, guarantee dignified work conditions to their artisans and, of course, a right retribution. All those issues are verified and certificated by *RugMark* every three months.

HIMALAYAN  
UNDYED

## TECHNICAL INFORMATION

### RUG NAME

# ANNAPURNA 1

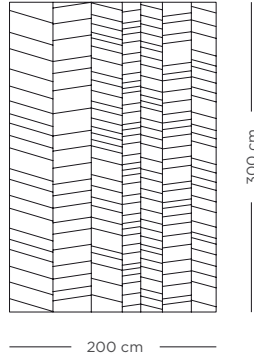

### FEATURES

Hand knotted rug

#### KNOTS/INCH<sup>2</sup>

60 knt/inch<sup>2</sup>

#### KNOT

Tibetan knot



#### PILE HEIGHT

10 mm

#### MATERIAL

100% himalayan undyed wool

#### PRODUCTION AREA

Nepal

#### SUGGESTED COLOR COMBINATION

1	3	5	Soil
2	4	6	Mud
7	8	9	Sand

Available in any color combinations  
and in single color version

#### DELIVERY TIME FROM ORDER

3 months

**NOTE** any different size available upon request



**RUG NAME**

**ANNAPURNA 2 RUNNER**

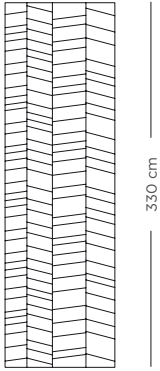

— 100 cm —

**FEATURES**

Hand knotted rug

**KNOTS/INCH<sup>2</sup>**

60 knt/inch<sup>2</sup>

**KNOT**

Tibetan knot



**PILE HEIGHT**

10 mm

**MATERIAL**

100% himalayan undyed wool

**PRODUCTION AREA**

Nepal

**SUGGESTED COLOR COMBINATION**



Available in any color combinations  
and in single color version

**DELIVERY TIME FROM ORDER**

3 months

**NOTE** any different size available upon request

**RUG NAME**

**ANNAPURNA 3**

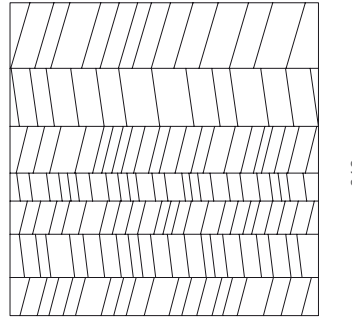

— 240 cm —

**FEATURES**

Hand knotted rug

**KNOTS/INCH<sup>2</sup>**

60 knt/inch<sup>2</sup>

**KNOT**

Tibetan knot



**PILE HEIGHT**

10 mm

**MATERIAL**

100% himalayan undyed wool

**PRODUCTION AREA**

Nepal

**SUGGESTED COLOR COMBINATION**



Available in any color combinations  
and in single color version

**DELIVERY TIME FROM ORDER**

3 months

**NOTE** any different size available upon request

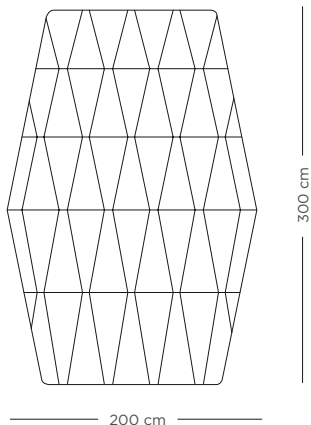
RUG NAME**LHOTSE 1**FEATURES

Hand knotted rug

KNOTS/INCH<sup>2</sup>

60 knt/inch<sup>2</sup>

KNOT

Tibetan knot + bouclé

PILE HEIGHT

10 mm

MATERIAL

100% himalayan undyed wool

PRODUCTION AREA

Nepal

COLOR

Available in all colors,  
only in single color version

DELIVERY TIME FROM ORDER

3 months

**NOTE** any different size available upon request

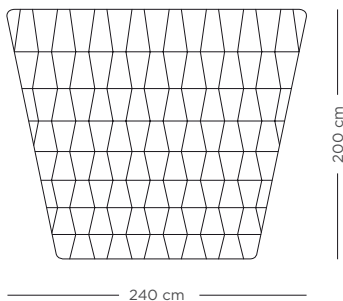
RUG NAME**LHOTSE 2**FEATURES

Hand knotted rug

KNOTS/INCH<sup>2</sup>

60 knt/inch<sup>2</sup>

KNOT

Tibetan knot + bouclé

PILE HEIGHT

10 mm

MATERIAL

100% himalayan undyed wool

PRODUCTION AREA

Nepal

COLOR

Available in all colors,  
only in single color version

DELIVERY TIME FROM ORDER

3 months

**NOTE** any different size available upon request

**RUG NAME**

**LHOTSE 3**

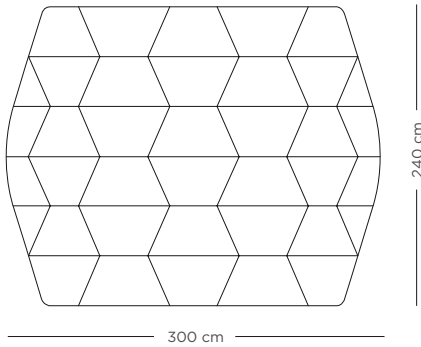

**FEATURES**

Hand knotted rug

**KNOTS/INCH<sup>2</sup>**  
60 knt/inch<sup>2</sup>

**KNOT**  
Tibetan knot + bouclé



**PILE HEIGHT**  
10 mm

**MATERIAL**  
100% himalayan undyed wool

**PRODUCTION AREA**  
Nepal

**COLOR**  
Available in all colors,  
only in single color version



**DELIVERY TIME FROM ORDER**  
3 months

**NOTE** any different size available upon request

**RUG NAME**

**LHOTSE 4**

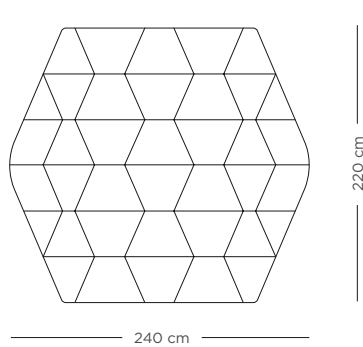

**FEATURES**

Hand knotted rug

**KNOTS/INCH<sup>2</sup>**  
60 knt/inch<sup>2</sup>

**KNOT**  
Tibetan knot + bouclé



**PILE HEIGHT**  
10 mm

**MATERIAL**  
100% himalayan undyed wool

**PRODUCTION AREA**  
Nepal

**COLOR**  
Available in all colors,  
only in single color version



**DELIVERY TIME FROM ORDER**  
3 months

**NOTE** any different size available upon request

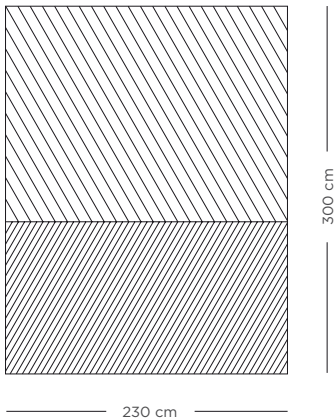
RUG NAME**TERAI 1**FEATURES

Hand knotted rug

KNOTS/INCH<sup>2</sup>

45 knt/inch<sup>2</sup>

KNOT

Tibetan knot + bouclé

PILE HEIGHT

20 mm

MATERIAL

100% himalayan undyed wool

PRODUCTION AREA

Nepal

COLOR

Available in all colors,  
also in two color version.

DELIVERY TIME FROM ORDER

3 months

**NOTE** any different size available upon request

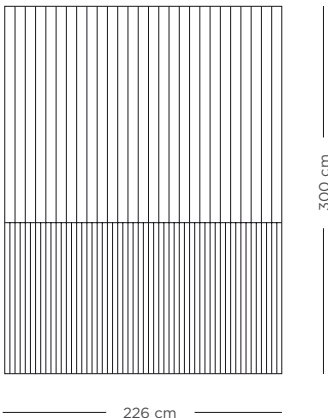
RUG NAME**TERAI 2**FEATURES

Hand knotted rug

KNOTS/INCH<sup>2</sup>

45 knt/inch<sup>2</sup>

KNOT

Tibetan knot + bouclé

PILE HEIGHT

20 mm

MATERIAL

100% himalayan undyed wool

PRODUCTION AREA

Nepal

COLOR

Available in all colors,  
also in two color version.

DELIVERY TIME FROM ORDER

3 months

**NOTE** any different size available upon request

**RUG NAME**

**TERAI 3**

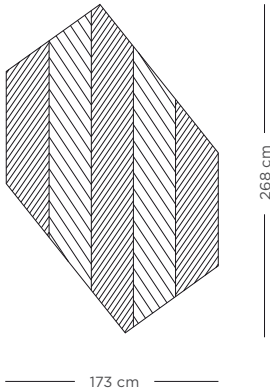

**FEATURES**

Hand knotted rug

**KNOTS/INCH<sup>2</sup>**  
45 knt/inch<sup>2</sup>

**KNOT**  
Tibetan knot + bouclé



**PILE HEIGHT**  
20 mm

**MATERIAL**  
100% himalayan undyed wool

**PRODUCTION AREA**  
Nepal

**COLOR**  
Available in all colors,  
also in two color version.



**DELIVERY TIME FROM ORDER**  
3 months

**NOTE** any different size available upon request

**RUG NAME**

**TERAI 4**

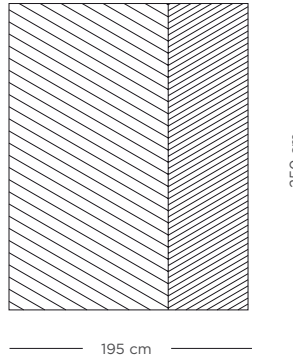

**FEATURES**

Hand knotted rug

**KNOTS/INCH<sup>2</sup>**  
45 knt/inch<sup>2</sup>

**KNOT**  
Tibetan knot + bouclé



**PILE HEIGHT**  
20 mm

**MATERIAL**  
100% himalayan undyed wool

**PRODUCTION AREA**  
Nepal

**COLOR**  
Available in all colors,  
also in two color version.



**DELIVERY TIME FROM ORDER**  
3 months

**NOTE** any different size available upon request

RUG NAME

# WANGDEN 1

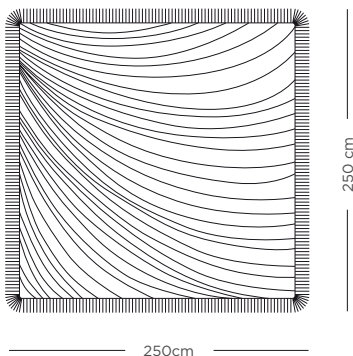

FEATURES

Hand knotted rug

**KNOTS/INCH<sup>2</sup>**

60 knt/inch<sup>2</sup>

**KNOT**

Tibetan knot



**PILE HEIGHT**

5 mm

**FRINGES HEIGHT**

80 mm

**MATERIAL**

100% himalayan undyed wool

**PRODUCTION AREA**

Nepal

**COLOR**

Available in the following color combinations:



**DELIVERY TIME FROM ORDER**

3 months

**NOTE** any different size available upon request

RUG NAME

# WANGDEN 2 RUNNER

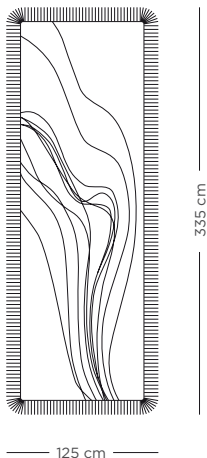

FEATURES

Hand knotted rug

**KNOTS/INCH<sup>2</sup>**

60 knt/inch<sup>2</sup>

**KNOT**

Tibetan knot



**PILE HEIGHT**

5 mm

**FRINGES HEIGHT**

80 mm

**MATERIAL**

100% himalayan undyed wool

**PRODUCTION AREA**

Nepal

**COLOR**

Available in the following color combinations:



**DELIVERY TIME FROM ORDER**

3 months

**NOTE** any different size available upon request

**RUG NAME**

**WANGDEN 3**

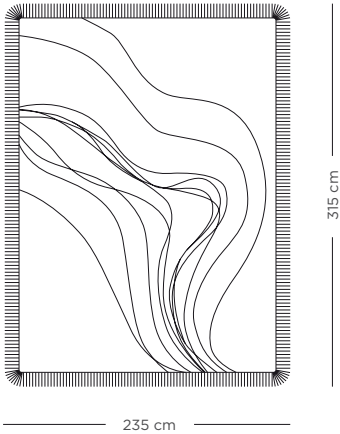

**FEATURES**

Hand knotted rug

**KNOTS/INCH<sup>2</sup>**

60 knt/inch<sup>2</sup>

**KNOT**

Tibetan knot



**PILE HEIGHT**

5 mm

**FRINGES HEIGHT**

80 mm

**MATERIAL**

100% himalayan undyed wool

**PRODUCTION AREA**

Nepal

**COLOR**

Available in the following color combinations:



**DELIVERY TIME FROM ORDER**

3 months

**NOTE** any different size available upon request

**ART DIRECTION**

Il Piccolo

**GRAPHIC DESIGN**

Normat

(Federico Boriani  
e Valentina Bianchi)

**PHOTOGRAPHY**

Marco Moretto

p 6-15 Prakash Shrestha

p 7 Marco Butturini

**PRINTING**

Tipografia Camisasca

**PAPER**

Phoenix Motion

Xenon, 170g

**THANKS** to Jesse for the  
Den stools by Bartoli Design

**NODUS THANKS** Bartoli Design  
and, in particular, Anna Bartoli  
for the passion they put  
in the project



**Il Piccolo  
Architettura d'interni**

via Delio Tessa 1

20121 Milano, Italy

ph. +39 02 866838

**[www.nodusrug.it](http://www.nodusrug.it)**