



nube

... a modern feeling

sofa armchairs & co.



_2



_3

odilon

poltrona

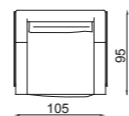
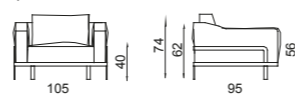

divano

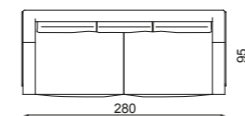
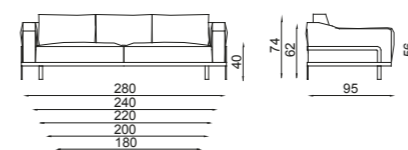

terminale

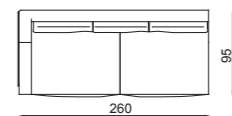
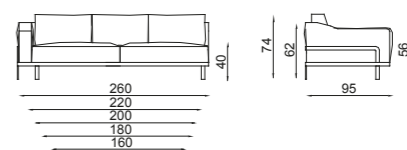

dormeuse

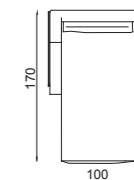
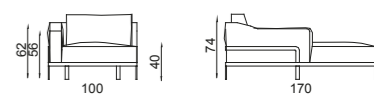

DESIGN_ Marco Corti



_4



_5

herry

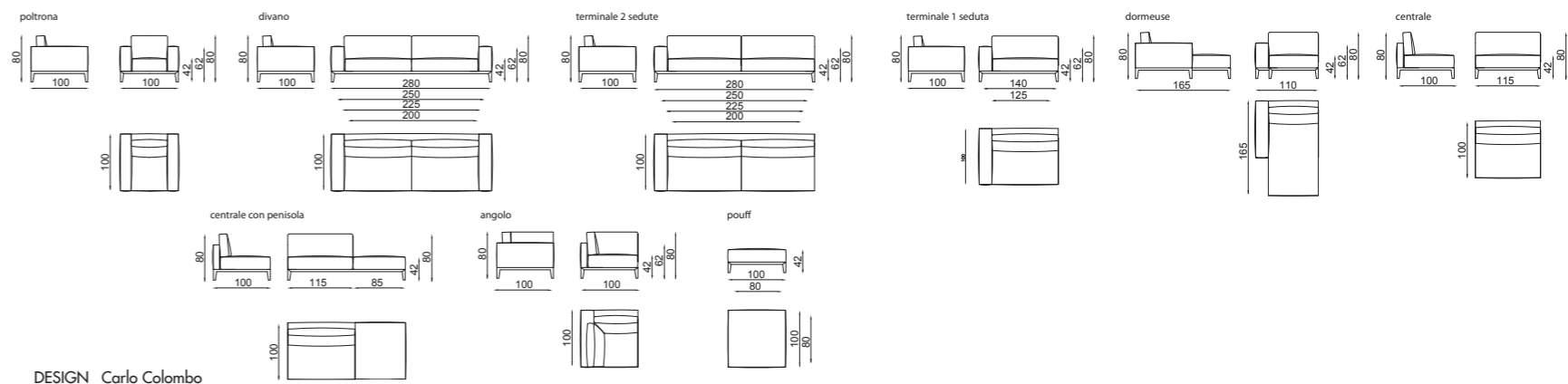



bryant 012

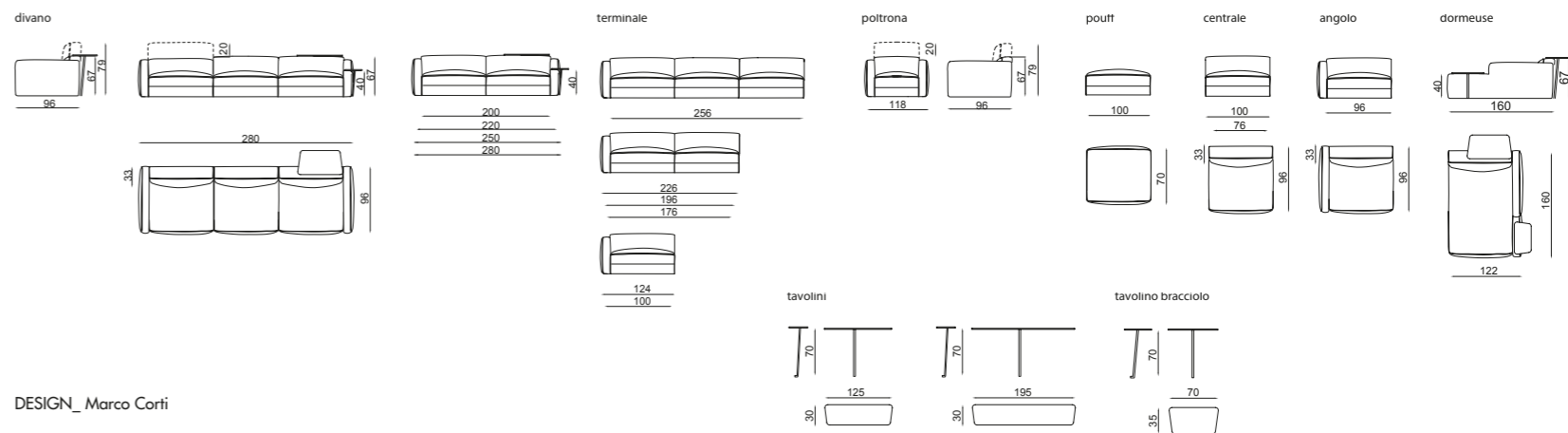



_8



_9

maxim

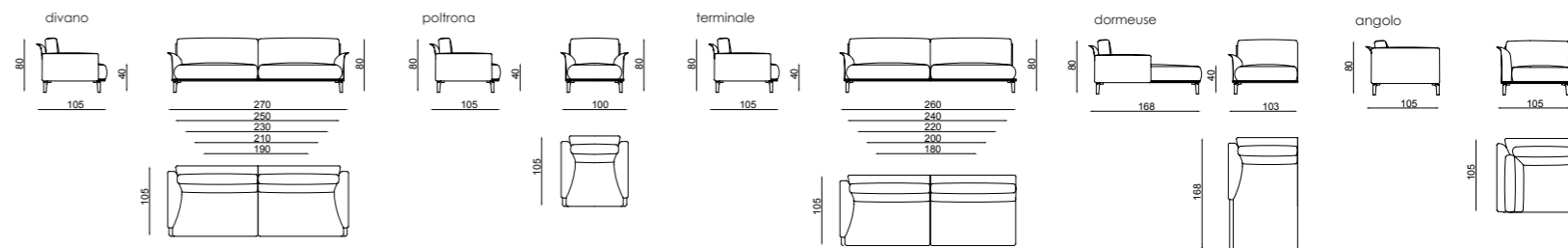

DESIGN_ Carlo Colombo



_10



_11

ioe

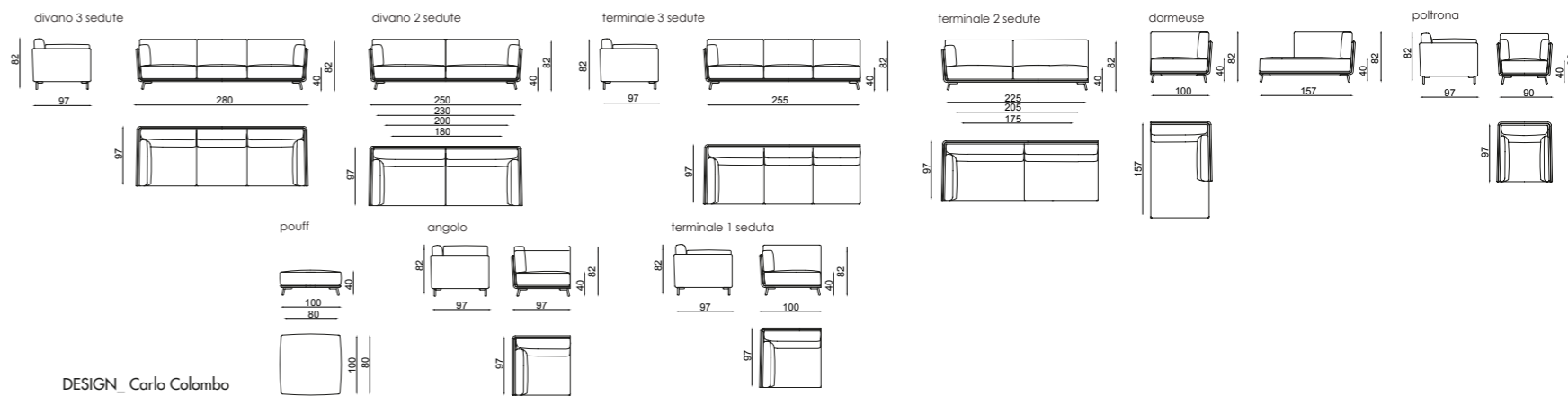



_12



_13

chloe

poltrona

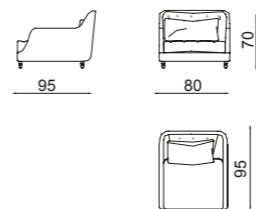

divano

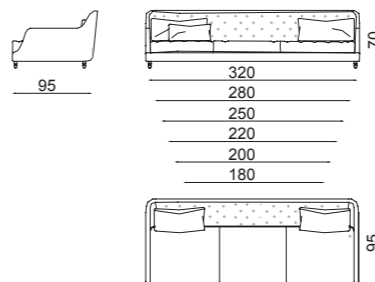

terminale

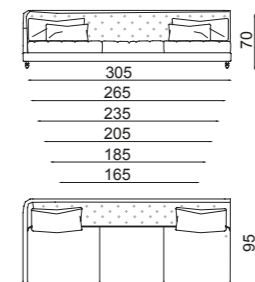

angolo

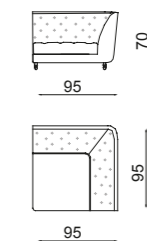



_14



_15

chloe

poltrona schienale alto

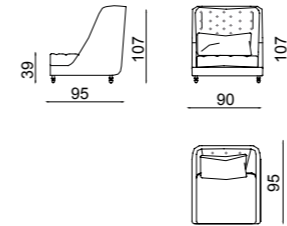

dormeuse

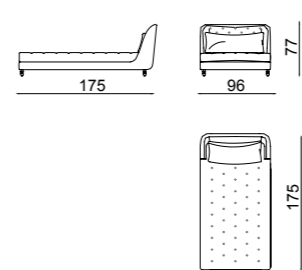

DESIGN_ Marco Corti



_16



_17

diva

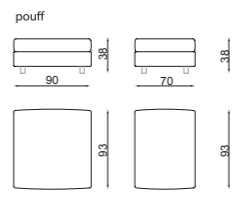
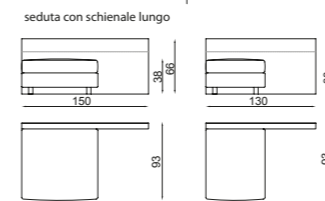
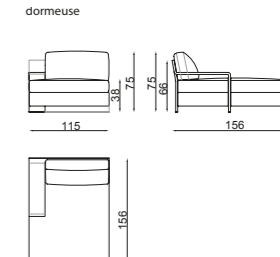
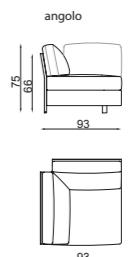
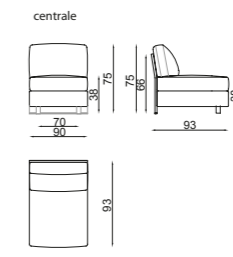
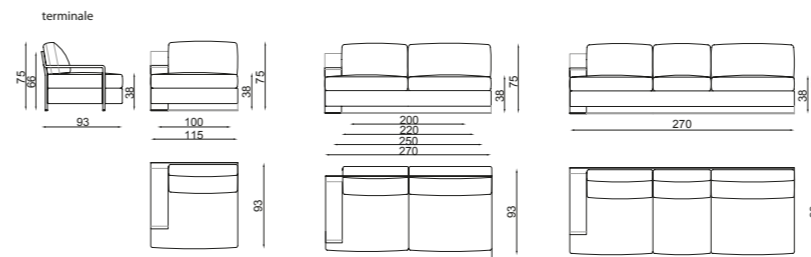
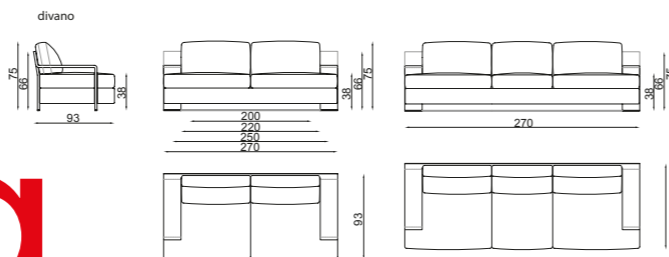

DESIGN_ Danilo Radice



_18



_19

book nest

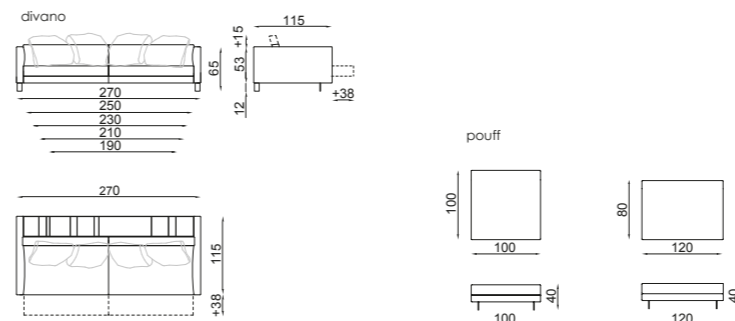

DESIGN_ Carlo Colombo



_20



_21

book nest 011

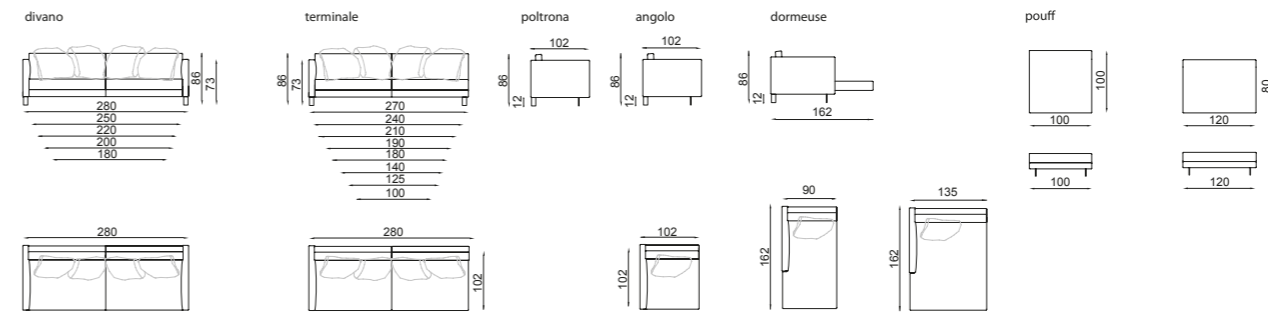

DESIGN_ Carlo Colombo



_22



_23

flatter

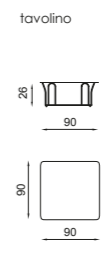
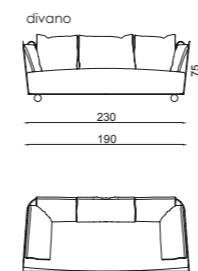

DESIGN_ Antonio Nicoli



_24



_25

geminini

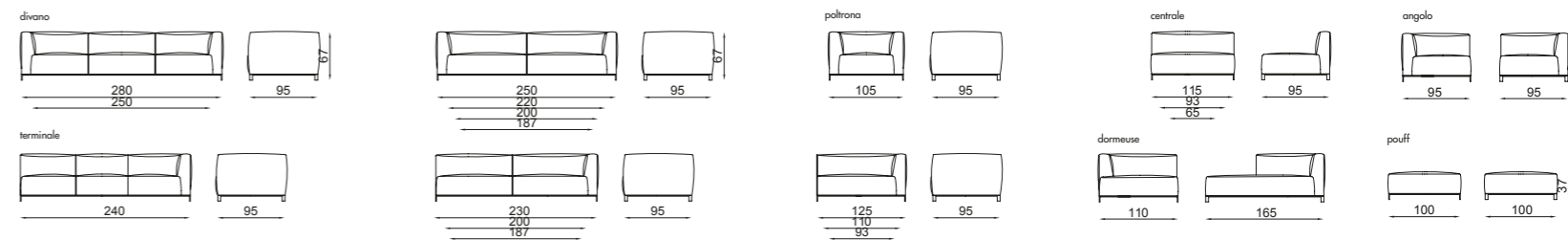

DESIGN_ Mario Ferrarini



romance

divano

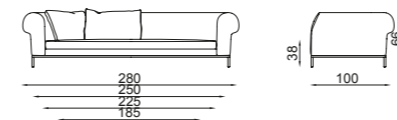

terminale

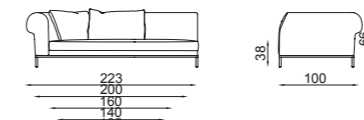

centrale

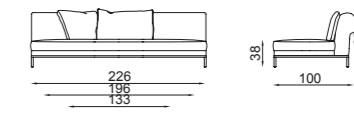

dormeuse

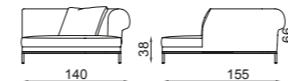

dormeuse



pouff

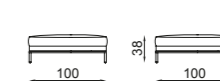



kybos

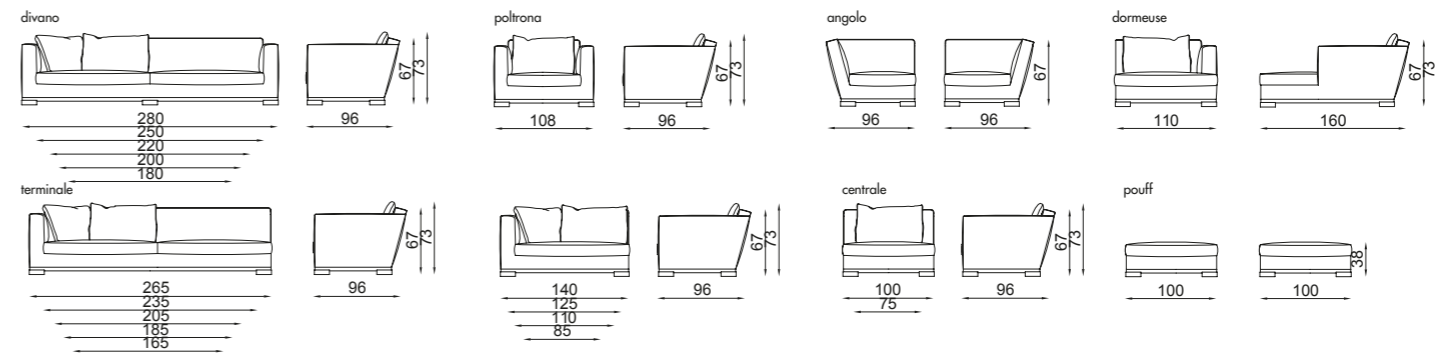



_30



_31

harbour

divano

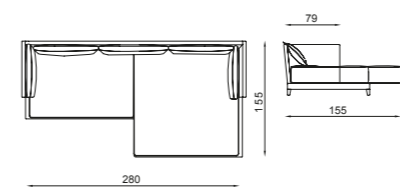
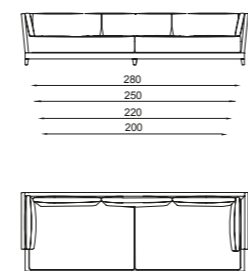

poltrona

79

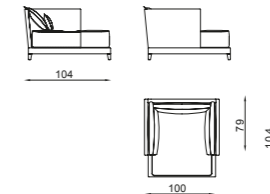

cuscino poggiatesta



DESIGN_ Marco Corti



_32



_33

remind

divano

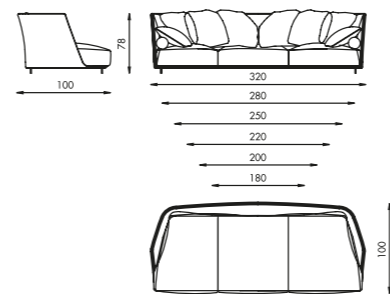

poltrona

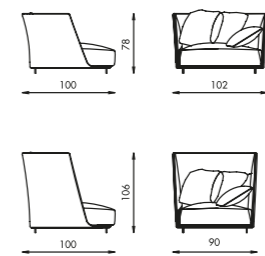

DESIGN_ Carlo Colombo



_34



_35

avenue

divano

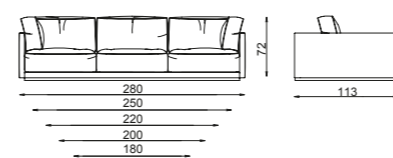

divano con dormeuse



poltrona

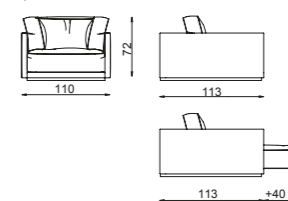



_36



_37

eddy

divano

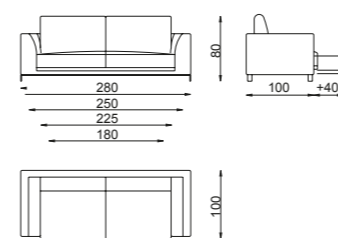

poltrona

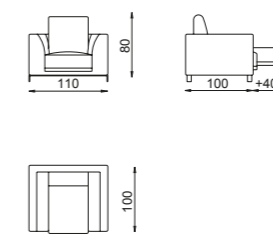



_38



_39

zar

terminale

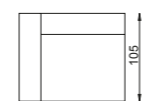
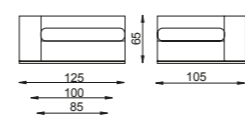

centrale

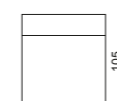
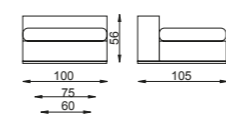

angolo

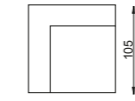
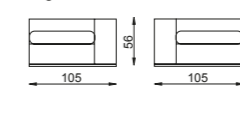

pouff

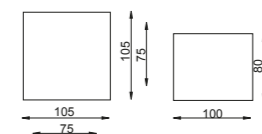



_40



_41

urban

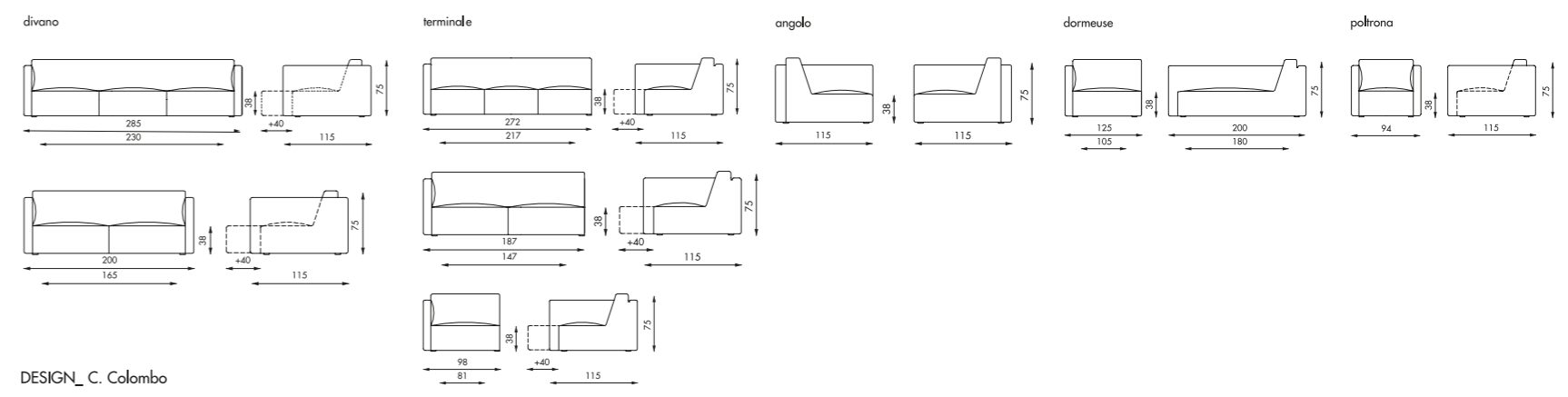



_42



_43

sleep

divano / letto

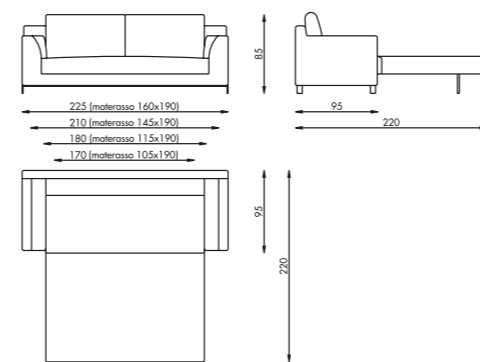

DESIGN_ Kemistry of Style

poltrona / letto

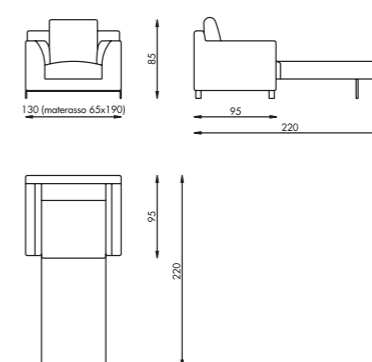



_44



_45

tempt.

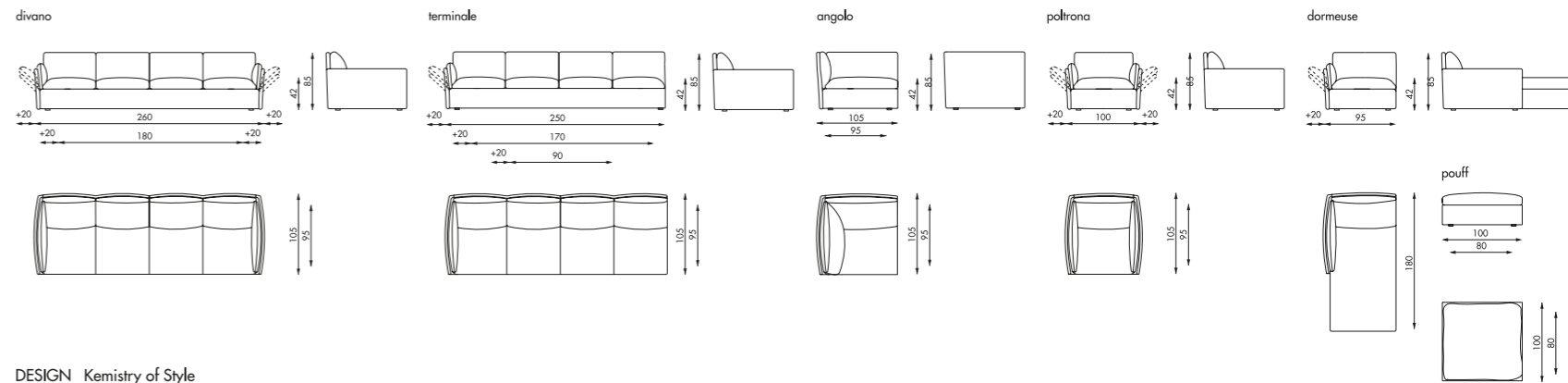

DESIGN_ Kemistry of Style



_46



_47

tender

divano

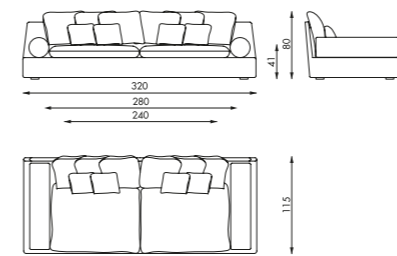

terminale

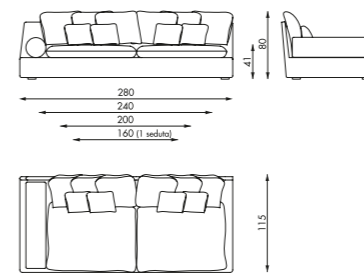

dormeuse

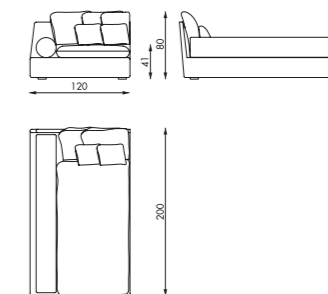

pouff

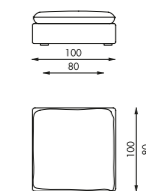

angolo

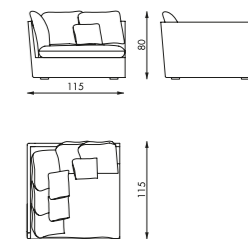

DESIGN_ C. Colombo



track

divano

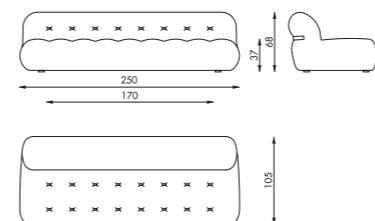

poltrona

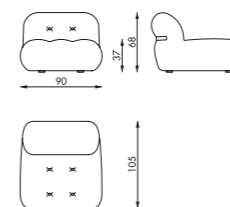

dormeuse

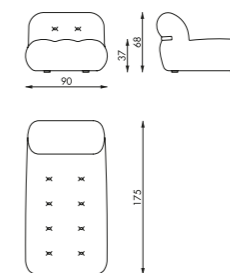

pouff

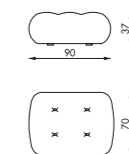



_50



_51

sophie

divano fisso

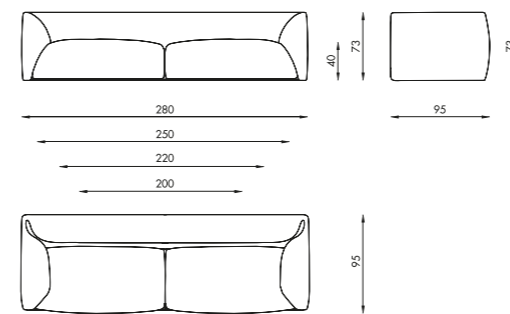

DESIGN_ Mario Ferrarini

divano con movimento

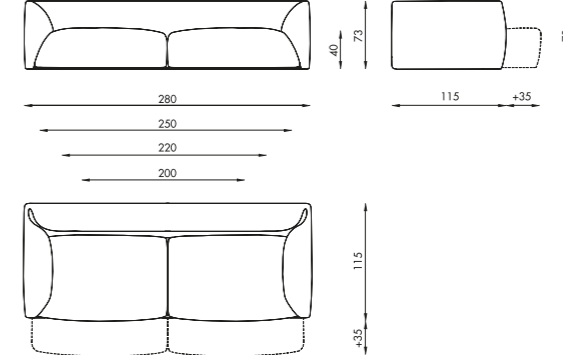



_52



_53

vertigo

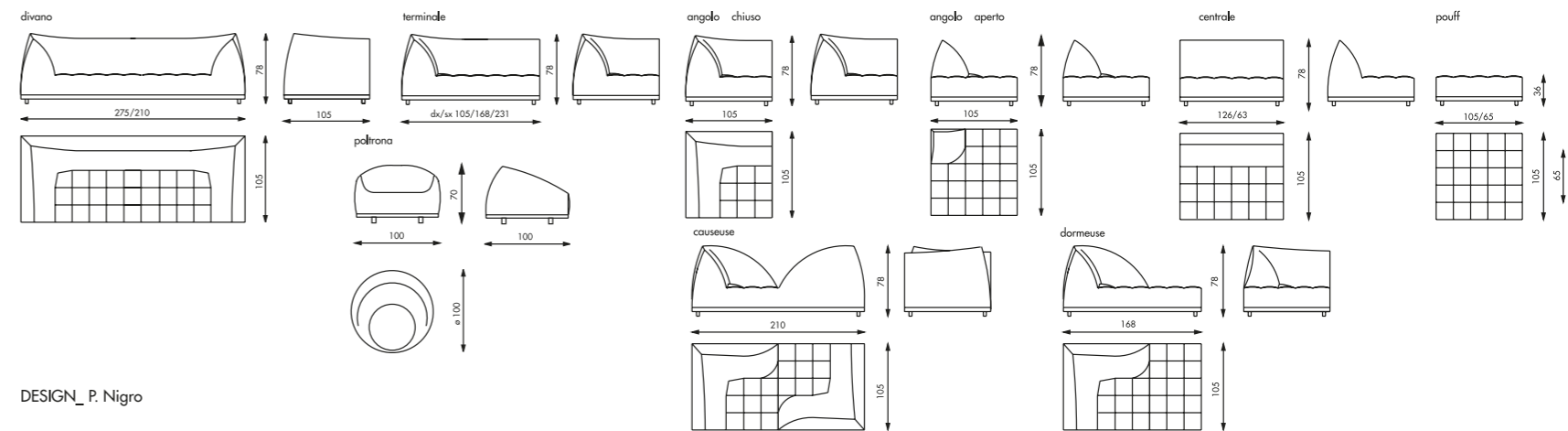

DESIGN_ P. Nigro



_54



_55

very_zona

very_

divano letto

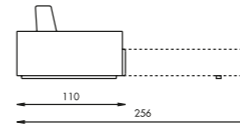
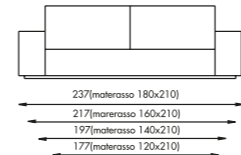

poltrona letto

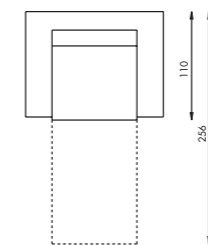

zona_bed

divano letto

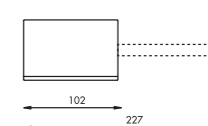
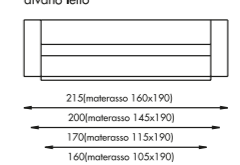

poltrona letto

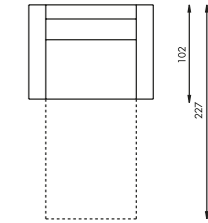

DESIGN_ Kemistry of style



_56

_57

zona

divano

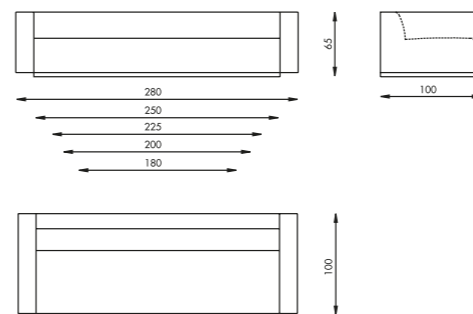

poltrona

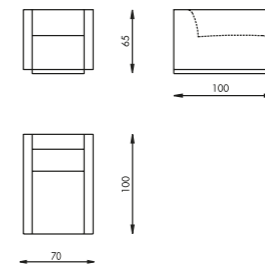

pouff

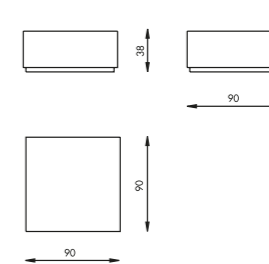

DESIGN_ C. Colombo_ M. Corti

_58



_59



london

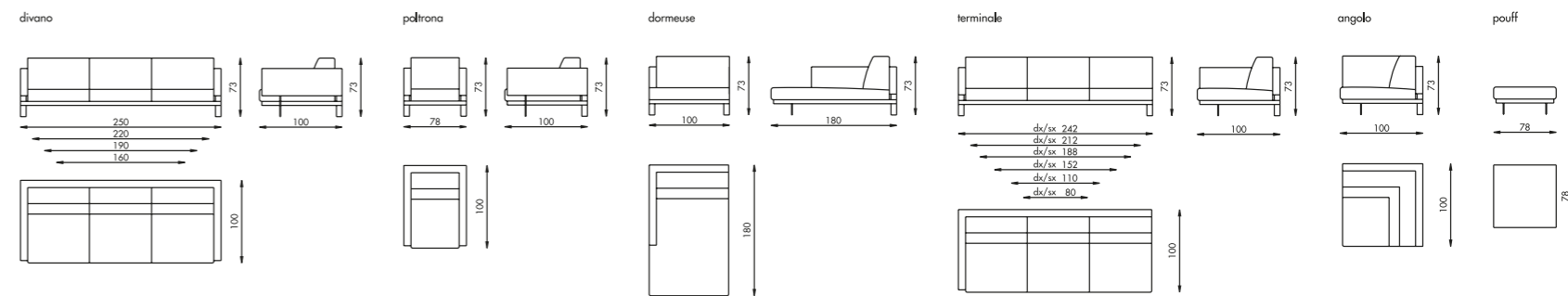

DESIGN_ M. Salvato



_60



_61

pacific coast

divano

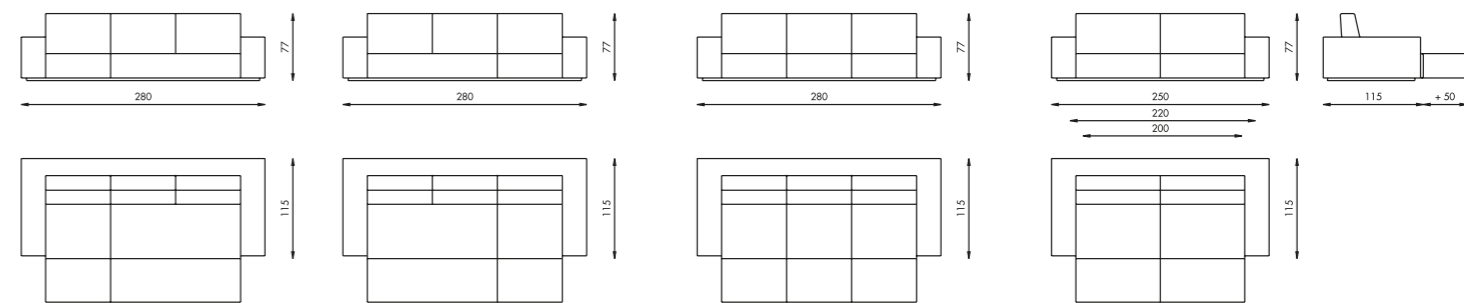

DESIGN_ C. Colombo



_62

_63

loom

poltroncina

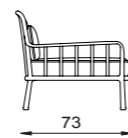
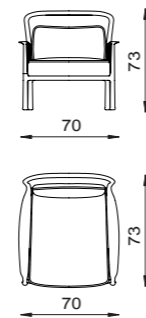

DESIGN_ M. Corti

poltroncina

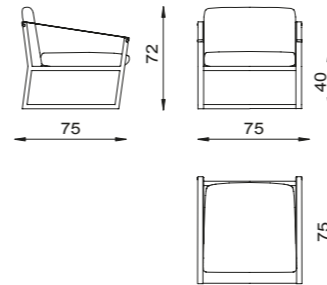

DESIGN_ M. Corti

softwood

_64



carlton

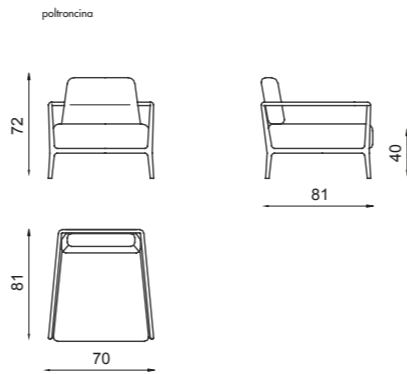

DESIGN_ M. Corti

_65

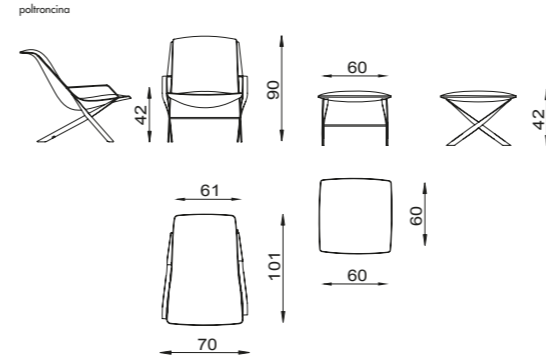

DESIGN_ Mario Ferrarini

samoa

_66



twist

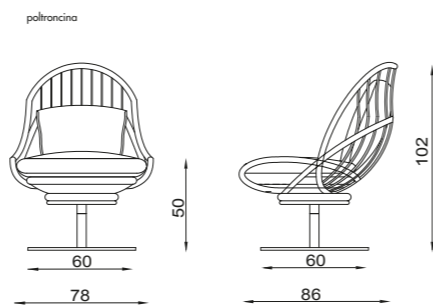

DESIGN_ Marco Corti

_67



fency

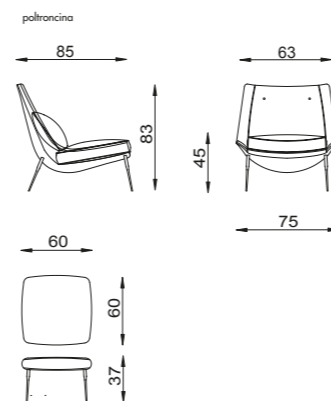

DESIGN_ Marco Corti



_68

stream

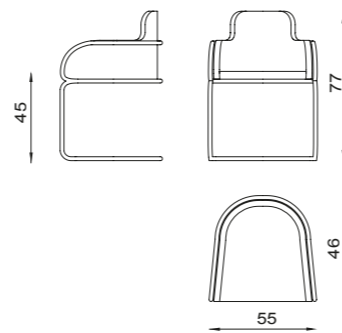

DESIGN_ M. Corti



_69

sir

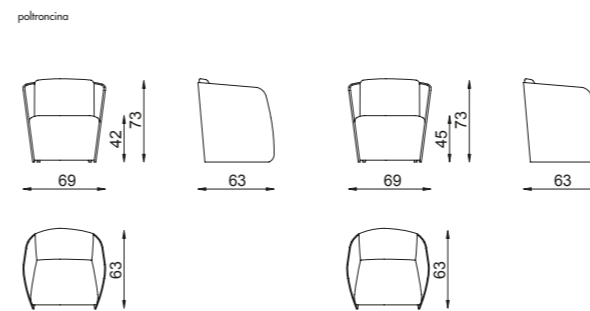

DESIGN_ Carlo Colombo

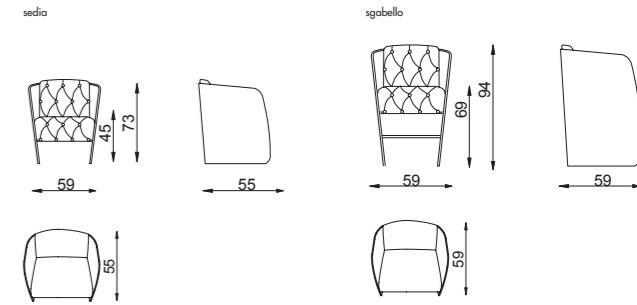



_70



_71

rest

poltrona



DESIGN_ Carlo Colombo



_72



_73

shelford

poltroncina

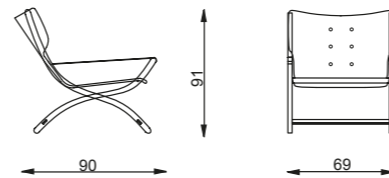

DESIGN_ Marco Corti



_74

_75

chiara

poltroncina

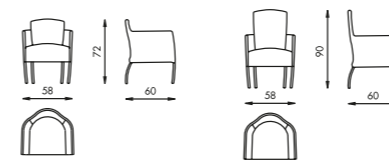

DESIGN_ C. Colombo



illy

poltroncina

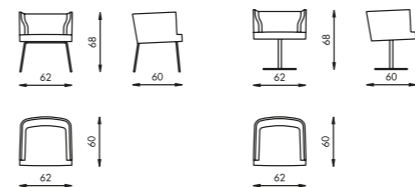

DESIGN_ C. Colombo

_78



gordon

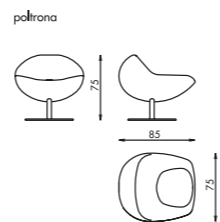

DESIGN_ Kemistry of Style

_79

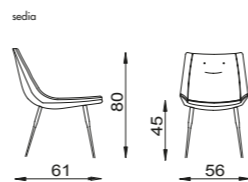

DESIGN_ Marco Corti

fency s



_80

_81

wiel

sedio



DESIGN_ Kemistry of style



_82



_83

mitos

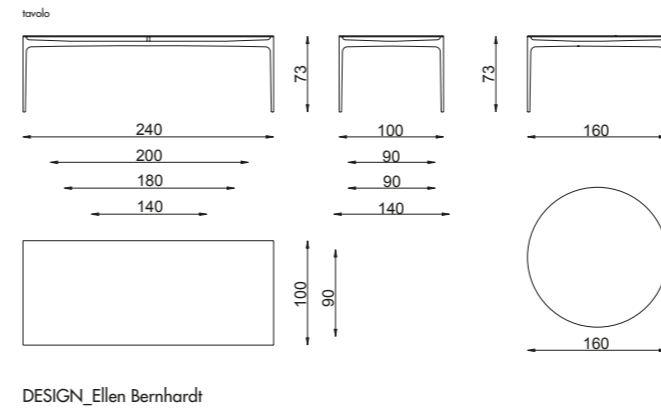
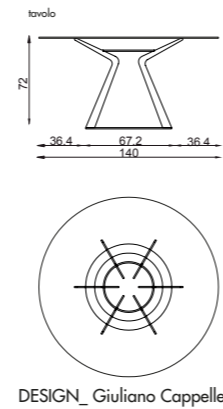

sweet



carlton

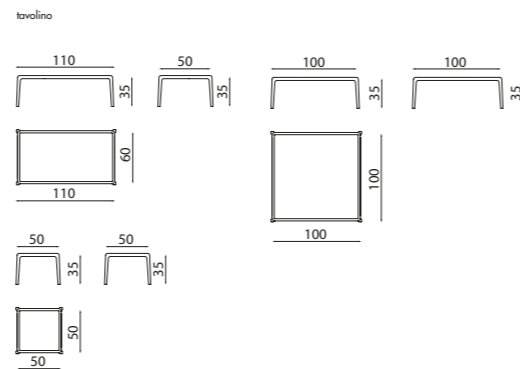

DESIGN_ Marco Corti

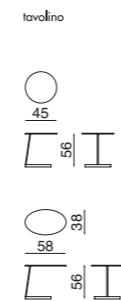

DESIGN_ Marco Corti

rise



_86

turn

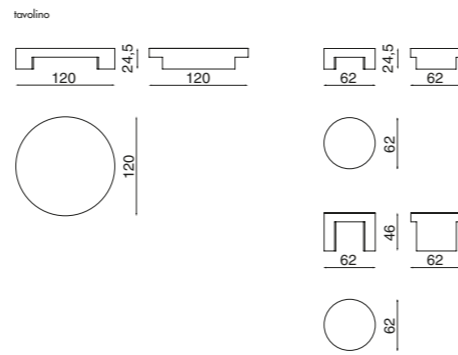

DESIGN_ C. Colombo



_87

circus

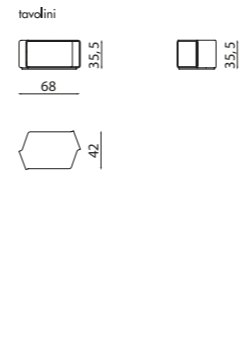

DESIGN_ Mario Ferrarini



_88



_89

link

tavolino

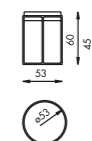
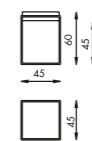
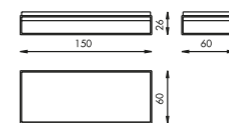
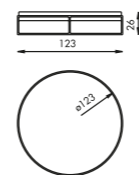
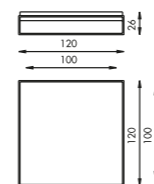

DESIGN_ R. Bello Dias



_92

raffles

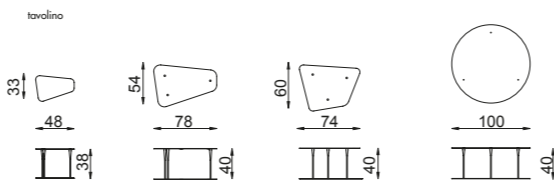

DESIGN_ Marco Corti

beds & co.



_94



_95

track

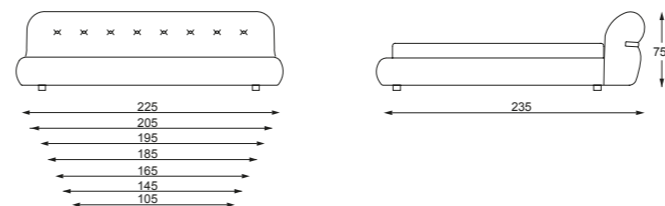

reti

- 200x195 cm
- 180x195 cm
- 170x195 cm
- 160x195 cm
- 140x195 cm
- 120x195 cm
- 80x195 cm

DESIGN_ Kemistry of Style



_96



_97

chloe

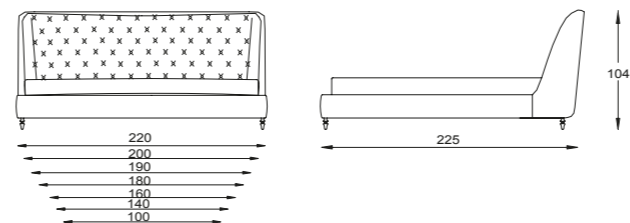

reti

- 200x200 cm
- 180x200 cm
- 170x200 cm
- 160x200 cm
- 140x200 cm
- 120x200 cm
- 80x200 cm

DESIGN_ Marco Corti



_98



_99

chloe 013

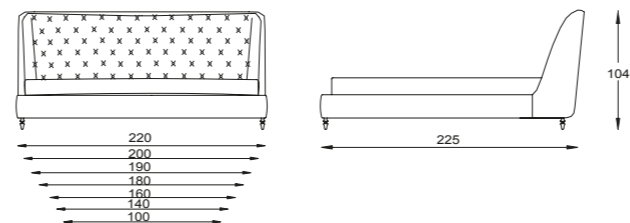

reli

- 200x200 cm
- 180x200 cm
- 170x200 cm
- 160x200 cm
- 140x200 cm
- 120x200 cm
- 80x200 cm

DESIGN_ Marco Corti



_100



_101

amos

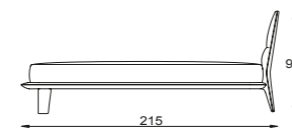
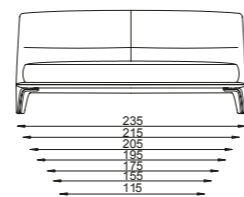

refi

200x200 cm
180x200 cm
170x200 cm
160x200 cm
140x200 cm
120x200 cm
80x200 cm

DESIGN_ Mario Ferrarini



_102



_103

gemini

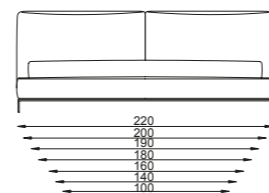

refi

200x200 cm
180x200 cm
170x200 cm
160x200 cm
140x200 cm
120x200 cm
80x200 cm

DESIGN_ Mario Ferrarini



_104



_105

flatter

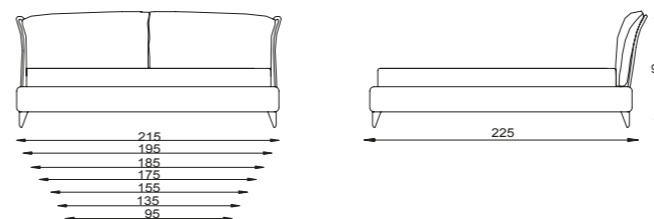

refi

200x200 cm
180x200 cm
170x200 cm
160x200 cm
140x200 cm
120x200 cm
80x200 cm

DESIGN_ Antonio Nicoli



_106

tender

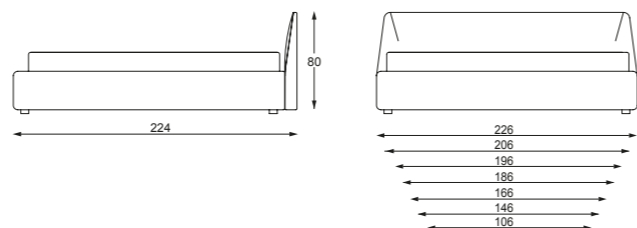

- reti
- 200x200 cm
 - 180x200 cm
 - 170x200 cm
 - 160x200 cm
 - 140x200 cm
 - 120x200 cm
 - 80x200 cm

DESIGN_ Marco Corti

lacquering & veneer



col. 1001_ BEIGE

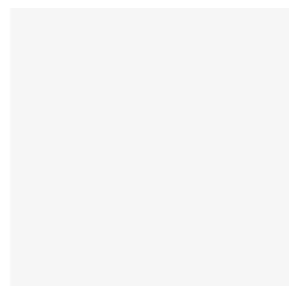

col. 9003_ BIANCO



col. 2008_ ARANCIO



col. 9017_ NERO



col. 3003_ ROSSO



col. 1019_ TORTORA



ZEBRANO



PALISSANDRO



ROVERE SBIANCATO



WENGÉ

_108

_109

laccature/lacquering

essenza/veneer

I dati che ci ha fornito, prestando consenso per il trattamento, verranno utilizzati ai sensi dell'art. 13 del D.Lgs. 196/03 (normativa sulla privacy) al fine di permettere l'espletamento degli adempimenti informativi, amministrativi, commerciali e contabili connessi al rapporto commerciale. Copia integrale dell'informativa potrà essere visionata presso la nostra sede.

The data his company has supplied us, lending assent for the treatment (consenso), will be used to the sense of the article 13 of D.Lgs 196/03 (Privacy consolidation act) in order to allow the realization of the fulfilments informatives, commercial and accounting connected to the contractual relationship. Integral copy of the informative could be request at our places of business.

nube

22060 Figino Serenza (CO) - Italia - via Don L.Meroni, 87 - tel. +39. 031.780.295 - fax. +39.031.781.958 - www.nubeitalia.com - nubeitalia@nubeitalia.com