

zanotta:

02	<i>Flamingo</i>
18	<i>Judy</i>
22	<i>Hotelroyal</i>
30	<i>Taschino</i>
34	<i>Calamo</i>
36	<i>Tweed</i>
48	<i>Emil</i>
52	<i>Niobe</i>

Flamingo

design
Damian Williamson,
2017

Composizione divano **Flamingo**
con cuscini schienale 74x43 cm in
tessuto Talento 27654 e cuscino
schienale 58x51 cm in tessuto Talco
27341, piedini in alluminio lucidato.
Cuscinetto 54x25 cm in tessuto
Quadrifoglio 27028.

Composition of **Flamingo** sofa
with back cushions 74x43 cm in
fabric Talento 27654 and back
cushion 58x51 cm in fabric Talco
27341, polished aluminum alloy feet.
Small cushion 54x25 cm in fabric
Quadrifoglio 27028.



Poltrona rivestita in
tessuto Talento 27625 /
Armchair in fabric
Talento 27625. **Ardea**,
omaggio a / homage
to Carlo Mollino, 1944

Tavolino / Small table
Emil, design Frank
Rettenbacher, 2014

Tavolino / Small table
Niobe, design Federica
Capitani, 2016

Tavolino, struttura in acciaio verniciato nero e piano in marmo nero Marquinia / Small table, black painted steel frame and top in black Marquinia marble. **Niobe**, design Federica Capitani, 2016



Poltrona, divani monoblocco e componibili. Piedini in lega di alluminio lucidato oppure verniciato colore nero. Struttura in acciaio. Molleggio su nastri elastici. Imbottitura in poliuretano/fibra poliestere termolegata. Cuscino seduta in poliuretano a quote differenziate/fibra poliestere termolegata. Rivestimento sfilabile in stoffa o in pelle. Il divano può essere completato con cuscini schienale e poggiatesta in piuma d'oca 100% vergine.

Armchair, monobloc and modular sofas. Polished or black painted aluminum alloy feet. Steel frame. Elastic strips suspension. Upholstery in polyurethane/heat-bound polyester fibre. Seat cushion upholstered with graduated polyurethane/heat-bound polyester fibre. Removable cover in fabric or leather. The sofa can be equipped with back and lumbar cushions upholstered with goose feathers - 100% pure material.

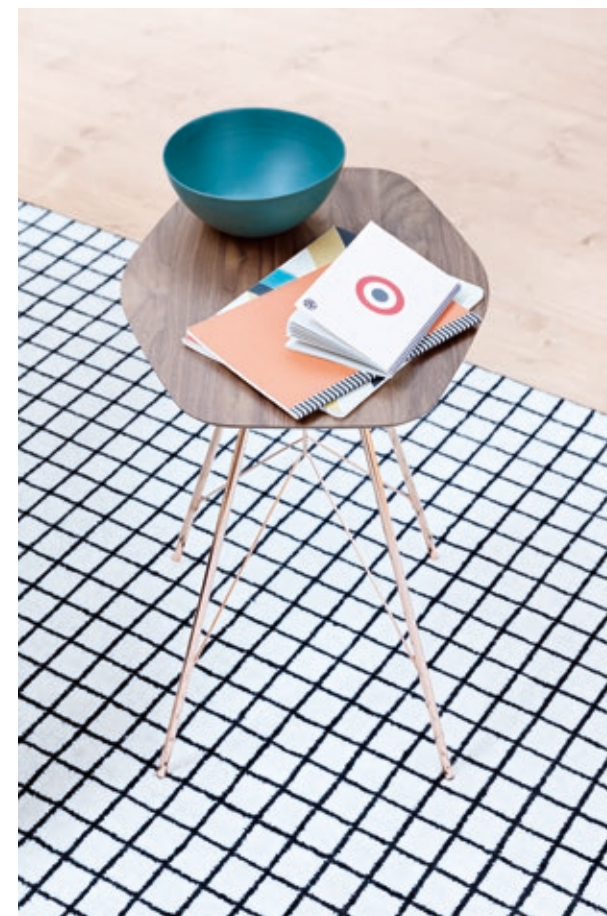

Tavolino, struttura in acciaio ramato lucido, piano in massello di noce Canaletto verniciato naturale / Small table, frame in polished coppery steel, natural painted solid Canaletto walnut top, **Emil**, design Frank Rettenbacher, 2014

Poltroncine in tessuto Teolo 30655, cuscino seduta in tessuto Teolo 30654, schienale in noce Canaletto, gambe in acciaio verniciato nero. / Armchairs in fabric Teolo 30655, seat cushion in fabric Teolo 30654, backrest in Canaletto walnut, black painted steel legs. **Judy**, design Frank Rettenbacher, 2017

Divano **Flamingo** con cuscini schienale 74x43 cm e 58x51 cm in tessuto Vins 27756, piedini verniciati nero.

Flamingo sofa with back cushions 74x43 cm and 58x51 cm in fabric Vins 27756, black painted feet.

Tavolino / Small table **Niobe**, design Federica Capitani, 2016





Poltroncine in tessuto Teolo 30655, cuscino seduta in tessuto Teolo 30654, schienale in noce Canaletto, gambe in acciaio verniciato nero. / Armchairs in fabric Teolo 30655, seat cushion in fabric Teolo 30654, backrest in Canaletto walnut, black painted steel legs. **Judy**, design Frank Rettenbacher, 2017

Composizione divano **Flamingo**, in tessuto Vins 27704, cuscini schienale 74x43 cm in tessuto Talco 27340, 58x51 cm in Vins 27704 e 74x43 cm in Talento 27640, piedini in alluminio lucidato. Cuscinetti 54x25 cm in tessuto Quadrifoglio 27028 e in Pied de Poule 64804.

Composition of **Flamingo** sofa, in fabric Vins 27704, back cushions 74x43 cm in fabric Talco 27340, 58x51 cm in Vins 27704 and 74x43 cm in Talento 27640, polished aluminum alloy feet. Small cushions 54x25 cm in fabrics Quadrifoglio 27028 and in Pied de Poule 64804.

Poltroncina in pelle Nappa 0306, cuscino seduta in tessuto Teolo 30606, schienale in rovere tinto nero gambe in acciaio verniciato nero / Armchair in leather Nappa 0306, seat cushion in fabric Teolo 30606, backrest in black painted oak, black painted steel legs. **Judy** design Frank Rettenbacher, 2017.

Libreria / Bookcase **Joy**, design Achille Castiglioni, 1989



Tavolino / Small table, **Emil**, design Frank Rettenbacher, 2014.

Tavolino / Small table, **Niobe** design Federica Capitani, 2016.



Dettaglio della poltroncina **Judy** in pelle Nappa 0306, cuscino seduta in tessuto Teolo 30606, schienale in rovere tinto nero, gambe in acciaio verniciato nero / Close-up of Judy armchair in leather Nappa 0306, seat cushion in fabric Teolo 30606, backrest in black painted oak, black painted steel legs, design Frank Rettenbacher, 2017.



Dettagli del divano **Flamingo** in tessuto Vins 27704, piedini in alluminio lucidato, cuscinetto in tessuto Pied de Poule 64804 /Close-ups of Flamingo sofa in fabric Vins 27704, polished aluminum alloy feet, small cushion in fabric Pied de Poule 64804.





Tavolino pieghevole /
Folding table, **Cumano**,
design Achille
Castiglioni, 1978

Tavolino / Small table
Niobe, design Federica
Capitani, 2016

Tavolino / Small
table, **Tempo**, design
Prospero Rasulo, 2001

Divano **Flamingo** con cuscini
schienale 74x43 cm in pelle Extra
0438, piedini verniciati nero.
Cuscinetti 54x25 cm in tessuto
Talento 27644.

Flamingo sofa with backrest
cushions 74x43 cm in leather
Extra 0438, black painted feet.
Small cushions 54x25 cm in fabric
Talento 27644.

Poltrone **Flamingo** con
cuscini schienale 74x43 cm
in tessuto Talento 27644,
piedini verniciati nero.

Flamingo armchairs
with back cushions 74x43 cm
in fabric Talento 27644,
black painted feet.

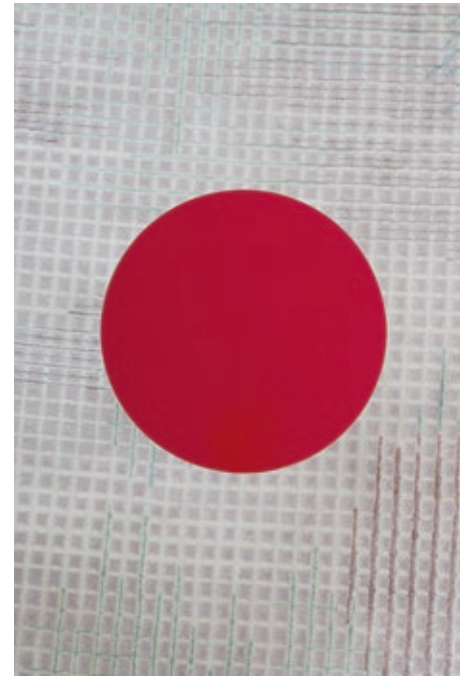

Tavolino / Small table, **Tempo**, design Prospero Rasulo, 2001



Poltrone **Flamingo** con cuscini schienale 74x43 cm in tessuto Talento 27644, piedini verniciati nero. Cuscinetto 54x25 cm in tessuto Pied de poule 64804

Flamingo armchairs with back cushions 74x43 cm in fabric Talento 27644, black painted feet. Small cushion 54x25 cm in fabric Pied de poule 64804

Judy

design
Frank Rettenbacher,
2017

Poltroncina **Judy**, in tessuto Teolo 30655, cuscino seduta in tessuto Teolo 30654, schienale in noce Canaletto, gambe in acciaio verniciato grafite

Judy armchair, in fabric Teolo 30655, seat cushion in fabric Teolo 30654, backrest in Canaletto walnut, graphite painted steel legs.



Poltroncina **Judy** in pelle Nappa 0306, cuscino seduta in tessuto Teolo 30606, schienale in rovere tinto nero, gambe in acciaio verniciato nero. Cuscinetto 44x44 cm in tessuto Pied de poule 64830

Judy armchair in leather Nappa 0306, seat cushion in fabric Teolo 30606, backrest in black painted oak, black painted steel legs. Small cushion 44x44 cm in fabric Pied de poule 64830.

Poltroncina **Judy** in tessuto Vins 27705, schienale in rovere naturale, gambe in acciaio verniciato grafite. Cuscinetto 52x27 cm in tessuto Pied de poule 64830

Judy armchair in fabric Vins 27705, backrest in natural oak, graphite painted steel legs. Small cushion 52x27 cm in fabric Pied de poule 64830



Sottoconsolle / bench **Quaderna**, design Superstudio, 1970



Poltroncina. Gambe in acciaio verniciato colore grafite o nero. Sedile in poliuretano rigido con imbottitura in poliuretano schiumato autoestinguente. Rivestimento sfilabile in stoffa o in pelle. Schienale in multistrato di faggio placcato in rovere verniciato naturale o tinto nero, oppure placcato in noce Canaletto verniciato colore naturale. Imbottitura schienale e cuscino sedile amovibile, rispettivamente in poliuretano e in poliuretano schiumato autoestinguente. Rivestimento sfilabile in stoffa o in pelle.

Armchair. Black or graphite painted steel legs. Stiff polyurethane seat with self-extinguishing polyurethane foam upholstery. Removable cover in fabric or leather. Backrest in beech plywood, covered with natural or black painted oak, or in natural painted Canaletto walnut. Backrest and seat cushion with removable upholstery, made of polyurethane and self-extinguishing polyurethane foam respectively. Removable cover in fabric or leather.



Poltroncina **Judy** in tessuto Quadrifoglio 27028, cuscino seduta in tessuto Quadrifoglio 27027, schienale in rovere naturale, gambe in acciaio verniciato grafite.

Judy armchair in fabric Quadrifoglio 27028, seat cushion in fabric Quadrifoglio 27027, backrest in natural oak, graphite painted steel legs.



Hotelroyal

design Terry Pecora,
2017

Letto **Hotelroyal** 236x214 cm
in tessuto Teolo 30658, struttura
e piedini in acciaio verniciato
grafite. Comodino in acciaio
verniciato grafite con piano
rivestito in cuoio pigmentato
0813. Cuscinetto 52x27 cm in
tessuto Quadrifoglio 27027

Hotelroyal bed 236x214 cm
in fabric Teolo 30658, graphite
painted steel frame and
feet. Night stand in graphite
painted steel with top covered
in cowhide pigmentato 0813.
Small cushion 52x27 cm in
fabric Quadrifoglio 27027.

Tavolino / Small table,
Emil, design Frank
Rettenbacher, 2014.

Poltrona anatomica
in tessuto Vip 27557 /
Anatomical easy-chair
in fabric Vip 27557,
Sacco, design Gatti,
Paolini, Teodoro, 1968





Letti. Piedini e struttura in acciaio verniciato colore grafite o bianco. Molleggio in doghe di faggio curvato, verniciato naturale. Testiera e pediera imbottite in poliuretano. Rivestimento, sfilabile, in stoffa o in pelle. A richiesta il bordo di cucitura è disponibile in canneté grigio scuro. Per il modello 1716 la testiera è dotata di un comodino realizzato in lamiera di acciaio verniciato colore grafite o bianco con piani rivestiti in cuoio pigmentato 90. A scelta la sua posizione può essere posta a destra o a sinistra del letto.

Beds. Graphite or white painted steel frame and feet. Suspension on natural painted bent beech strips. Headboard and footboard upholstered with polyurethane. Removable cover in fabric or leather. Upon request the sewing edge is available in dark grey grosgrain. For the model 1716 the headboard is equipped with a night stand made of graphite or white painted steel sheet, with top covered in cowhide pigmentato 90. The night stand can be arranged either on the left or on the right side of the bed, as requested.



Dettaglio letto **Hotelroyal** 236x214 cm in tessuto Teolo 30658, struttura e piedini in acciaio verniciato grafite. Comodino in acciaio verniciato grafite con piano rivestito in cuoio pigmentato 0813.

Close-up of **Hotelroyal** bed 236x214 cm in fabric Teolo 30658, graphite painted steel frame and feet. Night stand in graphite painted steel with top covered in cowhide pigmentato 0813.

Letto **Hotelroyal** 178x214 cm in tessuto Talento 27602, struttura e piedini in acciaio verniciato grafite, bordo di cucitura in canneté grigio scuro.

Hotelroyal bed 178x214 cm in fabric Talento 27602, graphite painted steel frame and feet, sewing edge in dark grey grosgrain.

Poltroncina in tessuto Quadrifoglio 27028, cuscino seduta in tessuto Quadrifoglio 27027, schienale in rovere naturale, gambe in acciaio verniciato grafite. / Armchair in fabric Quadrifoglio 27028, seat cushion in fabric Quadrifoglio 27027, backrest in natural oak, graphite painted steel legs. **Judy**, design Frank Rettenbacher, 2017.



Comodino con cassetto / Night stand with drawer, **Taschino**, design Gabriele Rosa, 2017

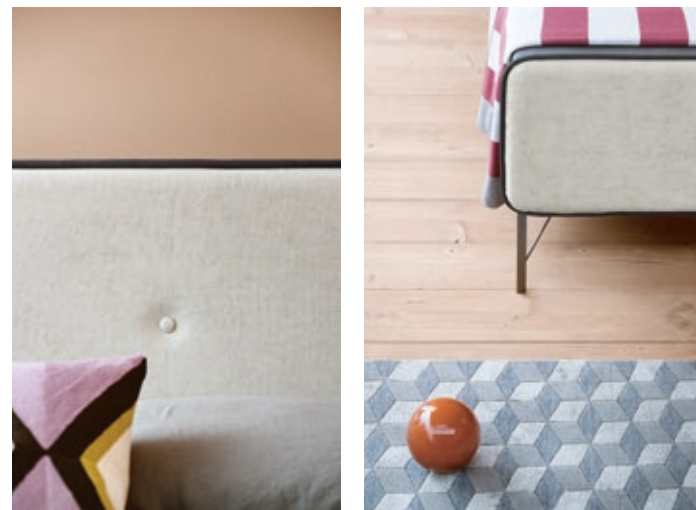

Dettaglio del letto **Hotelroyal** con bordo di cucitura in canneté grigio scuro.

Close-up of **Hotelroyal** bed with sewing edge in dark grey grosgrain.



Tavolino / Small table **Servomuto**, design Achille Castiglioni della serie / of the range **Servi** by Achille & Pier Giacomo Castiglioni, 1974

Letto **Hotelroyal** 178x214 cm
in tessuto Teolo 30604,
struttura e piedini in acciaio
verniciato bianco.

Hotelroyal bed 178x214 cm
in fabric Teolo 30604 white
painted steel frame and feet.



Comodino con cassetto /
Night stand with drawer,
Taschino, design
Gabriele Rosa, 2017

Scrittoio / desk
Calamo, design Gabriele
Rosa, 2013

Sgabello / Stool, **Ivo**,
design Frank
Rettenbacher, 2016



Poltroncina in tessuto
Quadrifoglio 27028,
cuscino seduta in
tessuto Quadrifoglio
27027, schienale in
rovere naturale, gambe
in acciaio verniciato
grafite. / Armchair in
fabric Quadrifoglio
27028, seat cushion in
fabric Quadrifoglio
27027, backrest in natural oak,
graphite painted steel
legs, **Judy**, design Frank
Rettenbacher, 2017

Taschino

design
Gabriele Rosa,
2017



Comodino con cassetto
Taschino, struttura
in acciaio verniciato
grafite, piano in cuoio
pigmentato 0813

Taschino night stand
with drawer, graphite
painted steel frame,
top in cowhide
pigmentato 0813.



Comodino con cassetto. Struttura e piano in acciaio verniciato colore bianco, nero o grafite. Piano e vano portaoggetti in cuoio pigmentato 90. Il vano è accessibile mediante apertura a ribalta ed è disponibile nella versione destra e sinistra.

Night stand with drawer. Top and frame in white, black or graphite painted steel. Top and storage space in cowhide pigmentato 90. The storage is accessed by a drop-leaf opening, available either for the right and the left side.



Comodino con cassetto **Taschino**, struttura in acciaio verniciato bianco, piano in cuoio pigmentato 0811.

Night stand with drawer **Taschino**, white painted steel frame, top in cowhide pigmentato 0811.



Dettaglio del letto **Hotelroyal** in tessuto Teolo 30604, piedini in acciaio verniciato grafite.

Close-up of **Hotelroyal** bed in fabric Teolo 30604, graphite painted steel feet.

Calamo

design
Gabriele Rosa,
2013



Scrivania **Calamo**,
struttura in acciaio
verniciato bianco, piano
in cuoio pigmentato 0811

Calamo desk, white
painted steel frame,
top in cowhide
pigmented 0811

Sgabello / Stool,
Ivo, design Frank
Rettenbacher,
2016

Scrivania. Struttura e
piano in acciaio verniciato
colore cromo, bianco,
nero o grafite. Piano e
vano portaoggetti in cuoio
pigmentato 90. Il vano
è accessibile mediante
apertura a ribalta

Desk. Varnished steel frame
and top in chrome, black,
white or graphite. Top and
storage space in cowhide
pigmented 90. The storage
space is accessed by a
drop-leaf opening.



Dettaglio del vano
portaoggetti, rivestito
in cuoio pigmentato 0811

Close-up of the storage
unit, covered in cowhide
pigmented 0811

Tweed

design
Garcia Cumini,
2017

Tavolo **Tweed** 300x100 cm,
piano in rovere verniciato
naturale e gambe in legno
massello di rovere.

Tweed table 300x100 cm,
top in natural painted oak
and legs in solid oak.

Sedie / Chairs, **June**
2056, design Frank
Rettenbacher, 2016





Dettaglio tavolo **Tweed**, piano in rovere verniciato naturale e gambe in legno massello di rovere.

Close-up of **Tweed** table, top in natural painted oak and legs in solid oak.

Sedie con schienale in rovere naturale, sedute in tessuto Quadrifoglio 27027, 27029, 27028, gambe in acciaio verniciato nero / Chairs with backrest in natural oak, seats in fabric Quadrifoglio 27027, 27029, 27028, black painted steel legs, **June** 2056, design Frank Rettenbacher, 2016

Tavoli. Piano in legno placcato in rovere, verniciato colore naturale, con sottopiano verniciato colore grigio o in noce Canaletto, verniciato colore naturale, con sottopiano verniciato colore nero. Gambe in abbinamento rispettivamente in legno massello di rovere, o di noce Canaletto, verniciato colore naturale.

Tables. Top available either in natural painted oak plated wood, with grey painted under-top, or in natural painted Canaletto walnut, with black painted under-top. Legs are available respectively in solid oak or Canaletto walnut, natural painted.



Sedie con schienale in rovere naturale, sedute in tessuto Quadrifoglio 27017 e 27023, gambe in acciaio verniciato nero / Chairs with backrest in natural oak, seats in fabric Quadrifoglio 27017 and 27023, black painted steel legs, **June** 2056, design Frank Rettenbacher, 2016

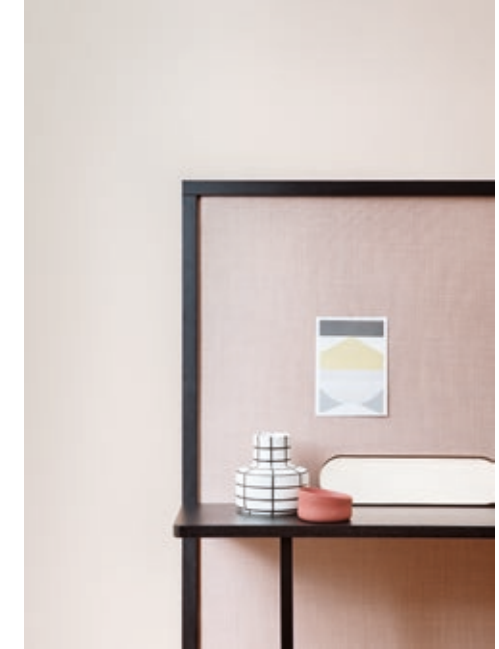

Paravento con mensola, struttura in rovere tinto nero, pannello rivestito in tessuto Quadrifoglio 27023 / Screen with console-shelf, black painted oak frame, covered with fabric Quadrifoglio 27023, **Shoji**, design LucidiPevere, 2015



Poltroncine in tessuto Talento 27644, in Vins 27747 e 27718, gambe in legno massello di noce Canaletto / Armchairs in fabrics Talento 27644, in Vins 27747 and 27718, legs in solid Canaletto walnut, **Liza** 2271/R, design Lievore, Altherr, Molina, 2015



Tavolo **Tweed** 213x102 cm, piano in noce Canaletto verniciato naturale e gambe in legno massello di noce Canaletto.

Tweed table 213x102 cm, top in natural painted Canaletto walnut and legs in solid Canaletto walnut.



Poltroncina / Armchair,
Liza 2271/R, design Lievore,
Altherr, Molina, 2015

Dettaglio tavolo **Tweed**,
piano in noce Canaletto
verniciato naturale e
gambe in legno massello
di noce Canaletto.
Close-up of **Tweed** table,
top in natural painted
Canaletto walnut and legs
in solid Canaletto walnut.

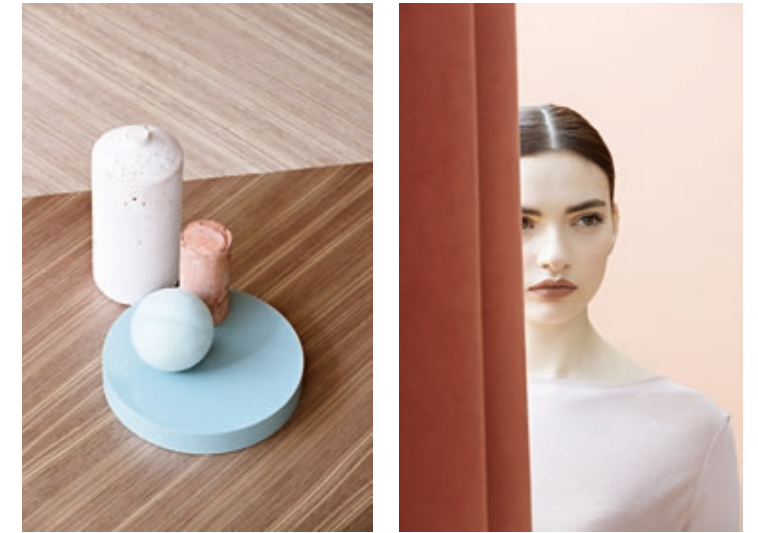



Tavolino / Small table,
Teti, design Prospero
 Rasulo, 2006

Tavolo **Tweed** 139x123 cm,
 piano in noce Canaletto
 verniciato naturale e
 gambe in legno massello
 di noce Canaletto.

Tweed table 139x123 cm,
 top in natural painted
 Canaletto walnut and legs
 in solid Canaletto walnut.



Sedia in cuoio 0714, gambe
 in alluminio verniciato nero /
 Chair in cowhide 0714, black
 painted aluminum legs,
Lia 2086, design Roberto
 Barbieri, 1998





Dettaglio tavolo **Tweed**, piano in noce Canaletto verniciato naturale e gambe in legno massello di noce Canaletto.

Close-up of **Tweed table**, top in natural painted Canaletto walnut and legs in solid Canaletto walnut.

Tavolino / Small table, **Teti**, design Prospero Rasulo, 2006



design
Frank Rettenbacher,
2014



Poltrona in tessuto
Talento 27625 / Armchair
in fabric Talento 27625.
Ardea, Omaggio a / homage
to Carlo Mollino, 1944

Tavolino. Struttura in acciaio
ramato lucido con piano in
massello di noce Canaletto
verniciato naturale oppure
ottonato lucido con piano in
massello di rovere verniciato
colore naturale.

Small table. Frame either in poli-
shed coppery steel, with natural
painted solid Canaletto walnut
top, or in polished brass-fini-
shed steel with natural painted
solid oak top.

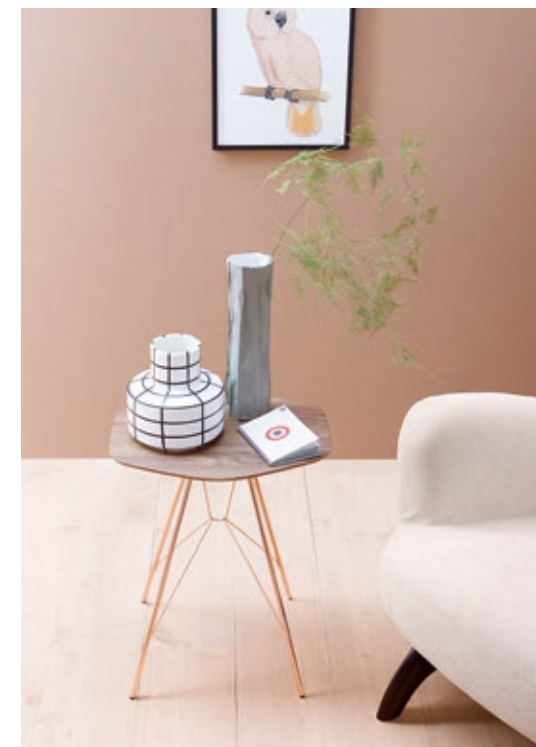

Tavolino **Emil**, struttura
in acciaio ramato lucido,
piano in massello di noce
Canaletto verniciato
naturale.
Emil small table, frame in
polished coppery steel,
natural painted solid
Canaletto walnut top.



Poltrona anatomica
in tessuto Vip 27517 /
Anatomical easy-chair
in fabric Vip 27517.
Sacco, design Gatti,
Paolini, Teodoro, 1968

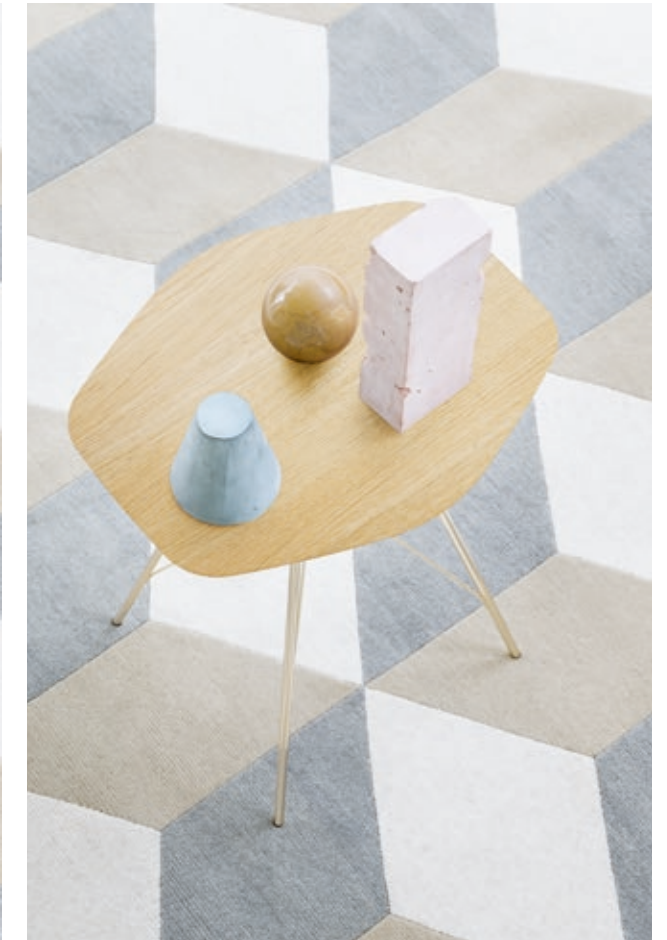

Tavolino **Emil**, struttura
in acciaio ottonato
lucido, piano in massello
di rovere verniciato
colore naturale.
Emil small table, in
polished brass-finished
steel, natural painted
solid oak top.

Niobe

design
Federica Capitani,
2016

Tavolino. Struttura in acciaio verniciato colore bianco o nero. Piani in marmo bianco di Carrara, in marmo nero Marquinia o in marmo Emperador, con verniciatura protettiva antimacchia, in poliestere trasparente opaco.

Small table. Steel frame painted in the shades black or white. Tops available either in white Carrara marble, in black Marquinia marble or in Emperador marble, with stain-resistant protective varnish, in clear matt polyester.



Divano / Sofa,
Flamingo,
design Damian
Williamson, 2017

Tavolino **Niobe**, struttura in acciaio verniciato nero, piano in marmo Emperador.

Niobe small table, black painted steel frame, Emperador marble top.



Tavolino **Niobe**, struttura in acciaio verniciato bianco, piano in marmo bianco di Carrara.

Niobe small table, white painted steel frame, white Carrara marble top.

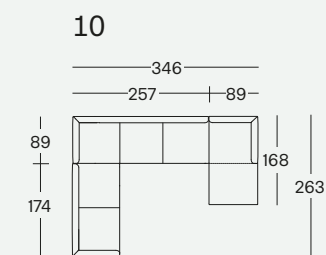
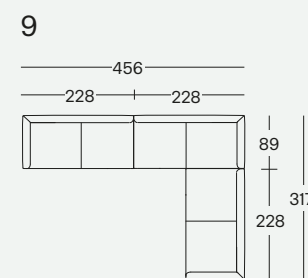
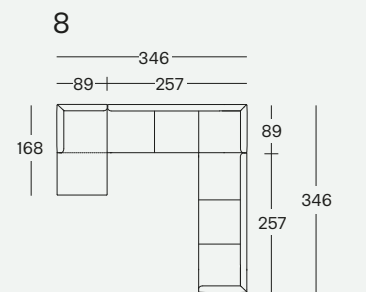
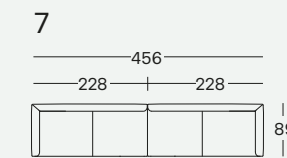
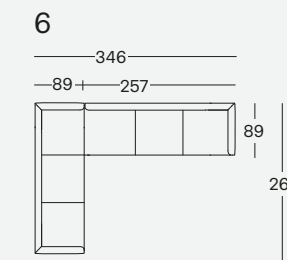
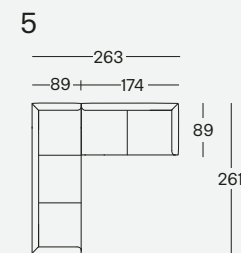
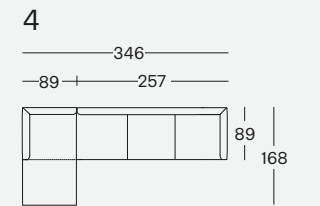
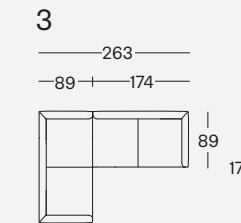
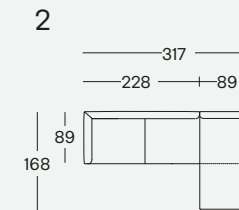
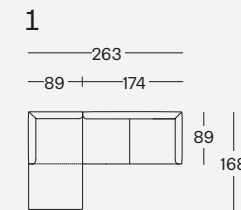
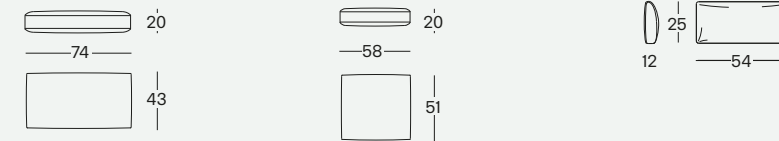
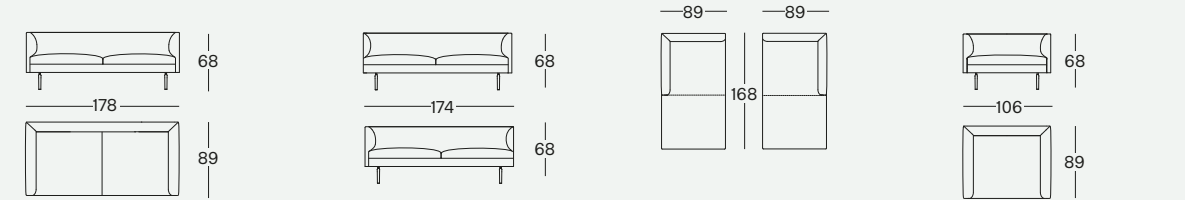
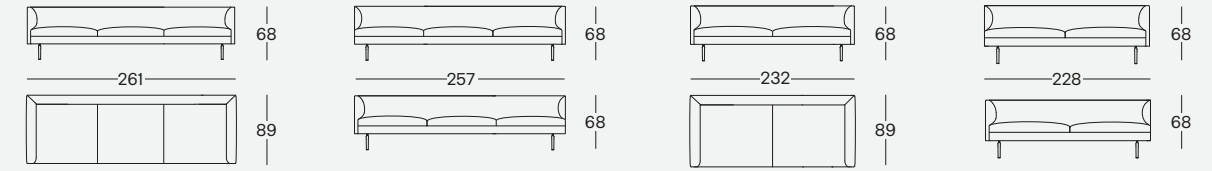

Judy: 890



Taschino: 643

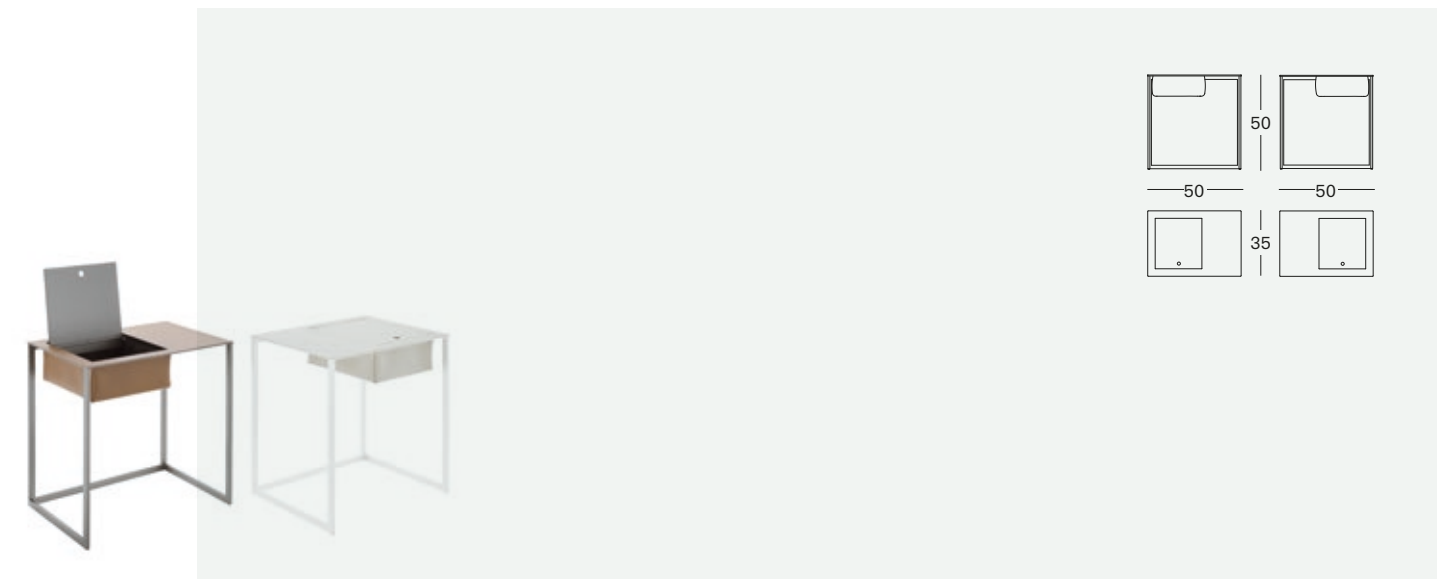

Hotelroyal: 1715/1716

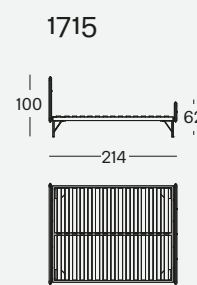

A richiesta sono disponibili anche le misure per i materassi da 210 e 220 cm. / Upon request the bed sizes for 210 cm. and 220 cm. long mattresses are also available.

- 168x214 cm
- 178x214 cm
- 188x214 cm
- 208x214 cm

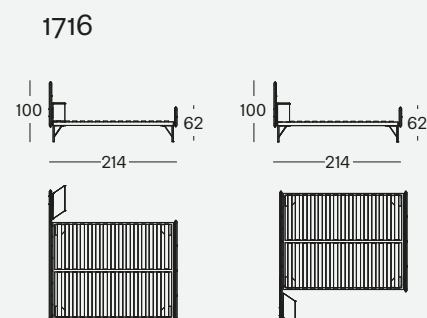

A richiesta sono disponibili anche le misure per i materassi da 210 e 220 cm. / Upon request the bed sizes for 210 cm. and 220 cm. long mattresses are also available.

- 226x214 cm
- 236x214 cm
- 246x214 cm
- 266x214 cm



Calamo: 2730



Tweed: 2317



Emil: 646

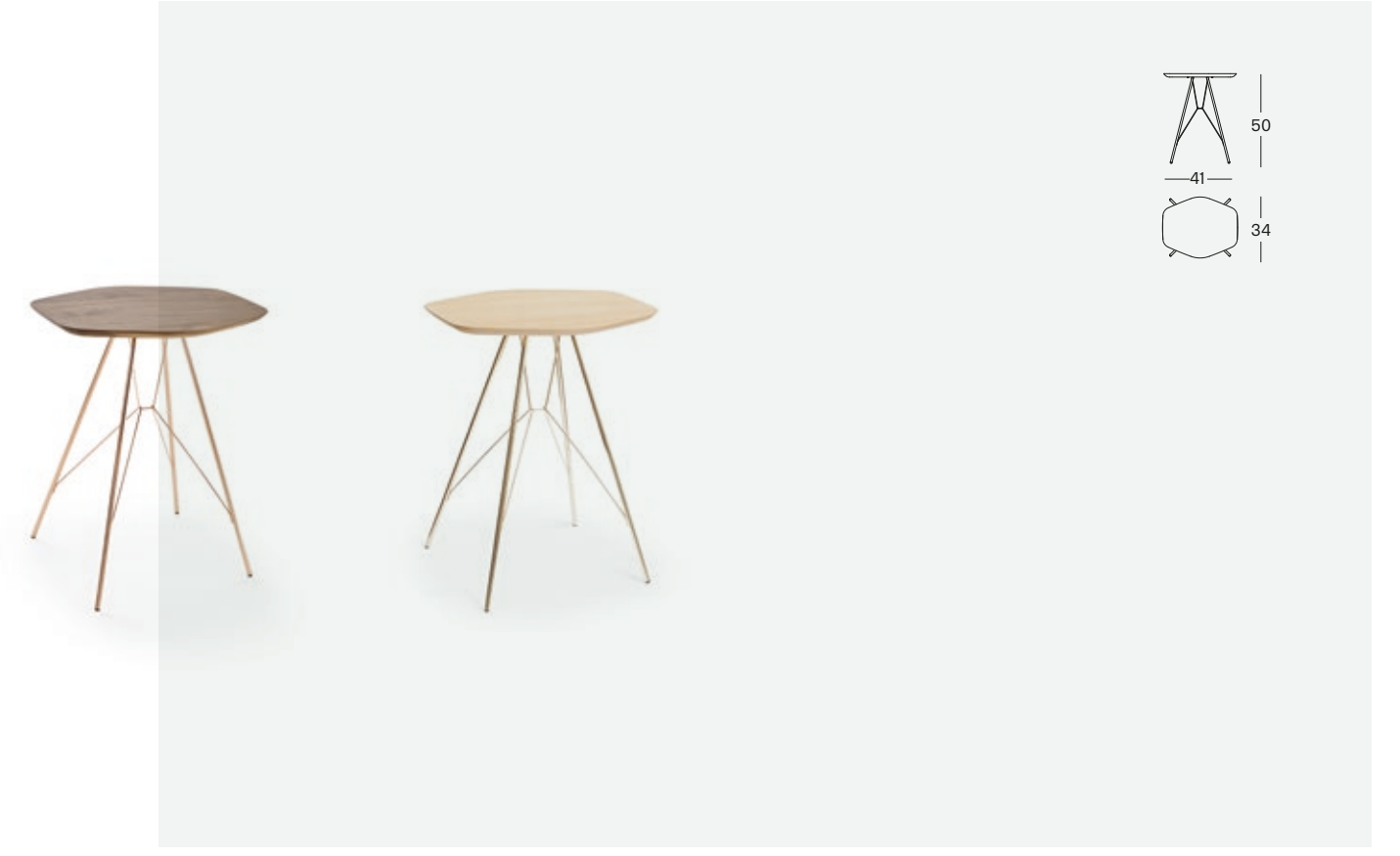

Niobe: 648

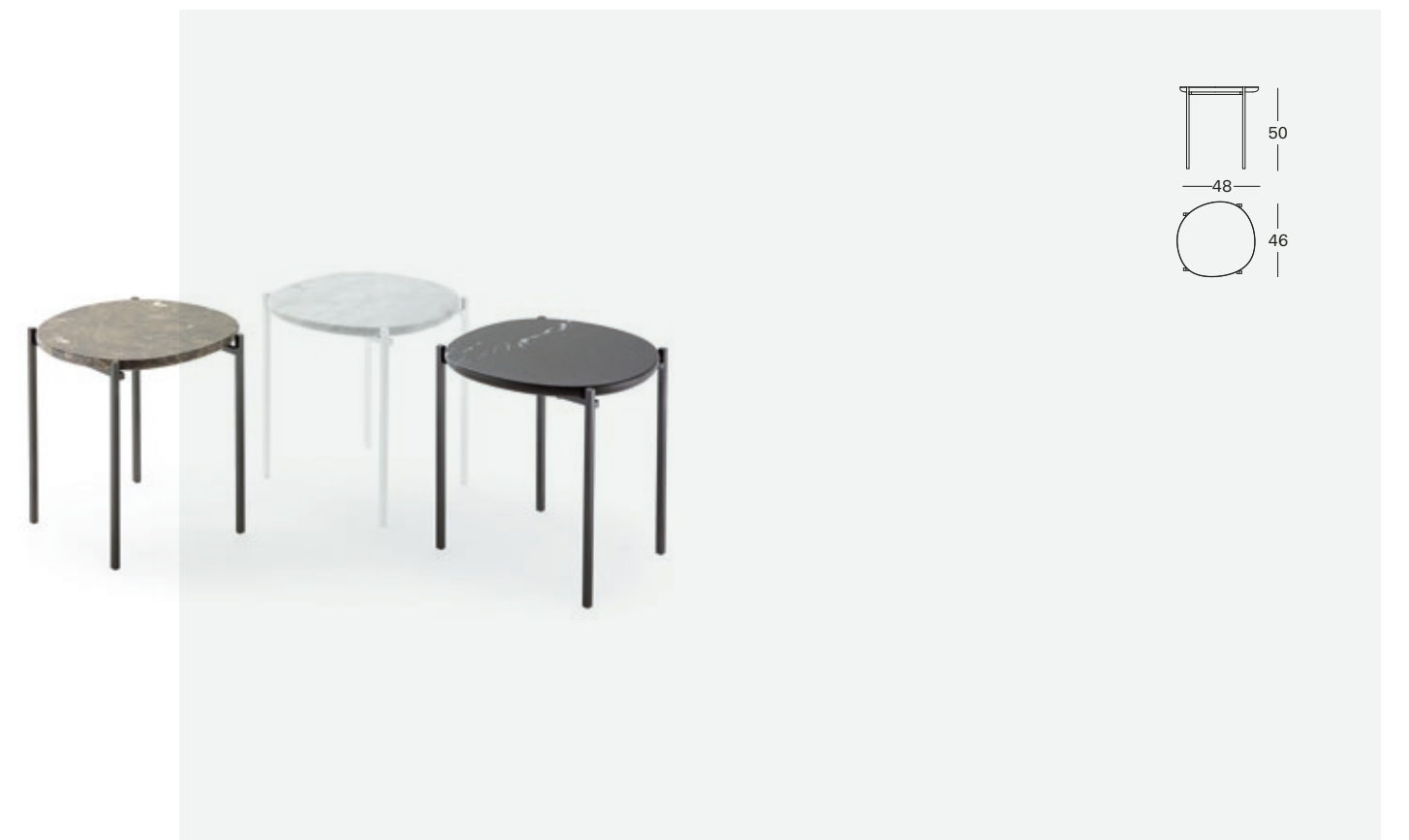

Concept,
graphic design
Leonardo Sonnoli,
Irene Bacchi
Studio Sonnoli

Set Design, styling
Studio Salaris
Photo
Beppe Brancato
Leo Torri

Pre-press
Diodo

Printing
Arti Grafiche Meroni,
Lissone

Thanks to
&k amsterdam
A.D.E.L.E. 1961
Agustina Bottoni
AYTM
Alcantara
Almerich
Alpi
Ames
Anvia
B.lux
Bosa
Brokis
cc-tapis
designrepublic.com
Estiluz
Golran
Incipit Lab
Kasthall
Kiasmo
Lyngby
Mani Ceramics
Mater
MM Lampadari
Menu
Nemo
Offiseria
Pallucco
Paola Paronetto
Pulpo
Roberta Licini
Sans Tabù
Sara Ricciardi
Shuj a private style
Studio Testo
Vanessa Mitrani

Copyright 2017
© Zanotta spa
All rights reserved

Zanotta spa si riserva di
apportare, senza preavviso,
modifiche nei materiali, nei
rivestimenti, nelle finiture
e nei disegni dei prodotti
presentati in questo
catalogo. Le textures
ed i colori dei materiali
e delle finiture hanno
valore indicativo in quanto
soggetti alle tolleranze dei
processi di stampa.

Zanotta spa reserves the
right to change, without
previous notice, materials,
covers, finishes and
drawings of the products
presented in this catalogue.
The textures and colours
of materials and finishes
are indicative as they
are depending on the
tolerances of the printing
process.