

Luceplan Acoustical Solutions

Diade
Farel
Pétale
Silenzio
Trypta

Contents

3 Light and acoustic comfort

5 All-in-one solutions

7 Diade

- 10 Chromatic Journey
- 12 Technical specifications
- 14 Application
- 17 Technical data

19 Farel

- 22 Technical specifications
- 24 Application
- 26 Colors combination
- 29 Technical data

31 Pétale

- 36 Technical specifications
- 38 Application
- 41 Technical data
- 42 Projects

51 Silenzio

- 54 Chromatic Journey
- 56 Technical specifications
- 58 Application
- 61 Technical data
- 62 Projects

75 Trypta

- 76 Chromatic Map
- 82 Suggested configurations
- 83 Technical data

Light and acoustic comfort

EN In shared spaces – for work, study, dining, leisure – noise pollution caused by unwelcome or irritating sounds can have a negative impact on human Psychological wellbeing. Lighting conditions also influence our mood and health, playing a fundamental role in the creation of a space suited to various needs. Supplying proper lighting and greater acoustic control at the same time – for better comprehension of speech and reduction of noise propagation – we make it possible to generate a comfortable environment, contributing to boost wellbeing and productivity.

IT Negli spazi collettivi - dedicati al lavoro, allo studio, alla ristorazione, al tempo libero - l'inquinamento acustico causato da un'eccessiva propagazione di rumori e suoni molesti, rischia di incidere negativamente sull'equilibrio psicofisico dell'uomo. Anche l'illuminazione influisce sul nostro benessere e svolge un ruolo fondamentale nella creazione di uno spazio adeguato alle varie esigenze. Fornire un'illuminazione adeguata e allo stesso tempo una maggiore qualità acustica – una migliore qualità del parlato e una riduzione della propagazione del suono – permette di realizzare un ambiente confortevole, contribuendo al miglioramento del benessere e della produttività.

DE In öffentlichen Räumen – im Bereich Arbeit, Studium, Gastronomie, Freizeit – kann sich die auf zu hohe Lärm- und Geräuschbelastung zurückgehende akustische Verschmutzung negativ auf die psychische und physische Gesundheit des Menschen auswirken. Auch die Beleuchtung beeinflusst unser Wohlbefinden und spielt bei Räumen, die unterschiedlichen Nutzungsansprüchen gerecht werden sollen, eine fundamental wichtige Rolle. Mit dem richtigen Licht und gleichzeitig auch einer stärkeren akustischen Kontrolle – bessere Sprachqualität und Schalldämpfung – gelingt es, angenehme Räume zu schaffen und so das persönliche Wohlbefinden und die Leistung zu verbessern.

FR Dans les espaces collectifs, dédiés au travail, à l'étude, à la restauration ou aux loisirs, la pollution acoustique causée par une excessive propagation de bruits et de sons agressifs risque d'influer négativement sur l'équilibre psychophysique des personnes. L'éclairage également a une influence sur notre bien-être et joue un rôle fondamental dans la création d'un espace adapté à différentes exigences. Fournir une illumination adéquate et, en même temps, une meilleure qualité acoustique - une meilleure qualité des conversations et une réduction de la propagation du son - permet de réaliser un environnement confortable, contribuant ainsi à améliorer le bien-être et la productivité.

ES En los espacios colectivos –dedicados al trabajo, al estudio, a la restauración o al tiempo libre– la contaminación acústica causada por una propagación excesiva de ruidos y sonidos molestos corre el riesgo de influir negativamente en el equilibrio psicofísico de las personas. También la iluminación influye en nuestro bienestar y desempeña un papel fundamental en la creación de un espacio adecuado para las distintas necesidades. Proporcionar una iluminación adecuada y, al mismo tiempo, una mayor calidad acústica –una mejor calidad del habla y una reducción de la propagación del sonido– permite crear un ambiente cómodo, contribuyendo a una mejora del bienestar y de la productividad.



Diade



Farel



Pétale



Silenzio

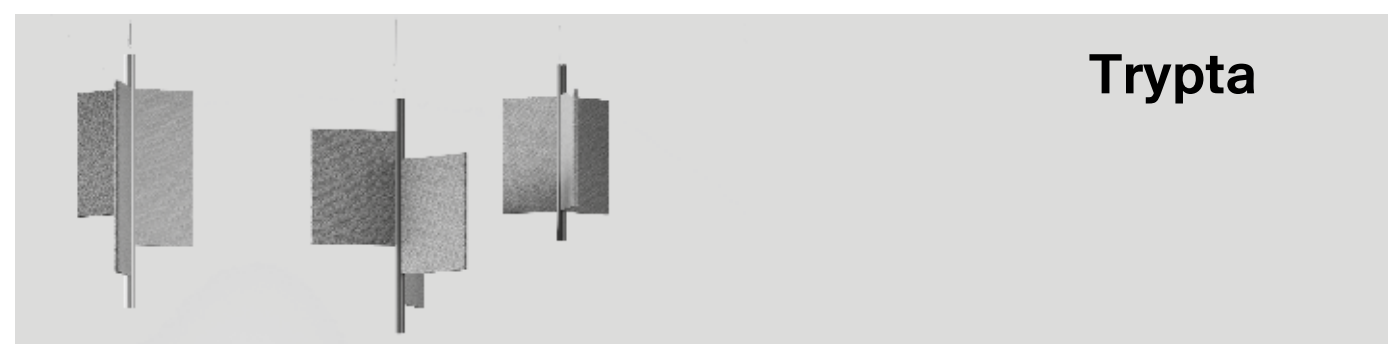

Trypta

All-in-one solutions

EN Luceplan has extensive experience in the creation of “all-in-one” solutions that combine high levels of technical lighting and sound-absorbing performance. A series of products that are true architectural parts capable of defining and personalizing any context. Lighting systems that combine solutions of decor and acoustic comfort for public and private settings, in creative approaches to the highest performance to match the beauty of design to the quality of light: tailor-made lighting that furnishes and customizes space, in a perfect balance of technology and design.

IT Luceplan vanta una consolidata esperienza in soluzioni “all-in-one” che combinano alte prestazioni illuminotecniche e elevate prestazioni di fono-assorbimento. Una serie di prodotti che sono veri e propri elementi architettonici capaci di definire e personalizzare gli ambienti. Sistemi di illuminazione che abbinano soluzioni d’arredo e comfort acustico per spazi pubblici e privati, risposte progettuali di grandi capacità prestazionali che accompagnano la bellezza del disegno alla qualità della luce: un’illuminazione sartoriale che arreda e personalizza l’ambiente, perfetta espressione del binomio tecnologia e design.

DE Luceplan verfügt über umfangreiche Erfahrung in „All-in-One“-Lösungen, die hohe lichttechnische Leistung und Hochleistungs-Schallabsorption vereinen. Eine Reihe an Produkten, die wahre modulare architektonische Elemente sind, ist in der Lage, Ambiente zu definieren und zu individualisieren. Es handelt sich um Beleuchtungssysteme, die Möblierungslösungen und akustischen Komfort in privaten und öffentlichen Räumen sowie Gestaltungsvorschläge von großer Leistungsfähigkeit kombinieren, welche die Schönheit des Designs durch Lichtqualität begleitet: eine maßgeschneiderte Beleuchtung, welche das Ambiente gestaltet und personalisiert - der perfekte Ausdruck des Tandems Technik und Design.

FR Luceplan possède une vaste expérience dans les solutions « all-in-one », qui allient des performances d’éclairage élevées et des performances d’insonorisation élevées. Une série de produits qui constituent des véritables éléments architecturaux modulaires en mesure de définir et de personnaliser les environnements. Des systèmes d’éclairage qui mêlent solutions d’ameublement et confort acoustique pour les espaces publics et privés, des réponses conceptuelles avec de grandes capacités de performance qui allient beauté du design et qualité de la lumière : un éclairage sur mesure qui meuble et personnalise l’environnement, l’expression parfaite du binôme technologie/design.

es Luceplan cuenta con una consolidada experiencia en soluciones «all-in-one» que combinan altas prestaciones luminotécnicas y fonoabsorbentes. Una serie de productos que son auténticos elementos arquitectónicos modulares capaces de definir y personalizar los ambientes. Sistemas de iluminación que ofrecen soluciones de decoración y comodidad acústica para espacios tanto públicos como privados, respuestas de diseño de grandes capacidades prestacionales que unen la belleza del diseño a la calidad de la luz: una iluminación a medida que decora y personaliza el ambiente, expresando perfectamente el binomio tecnología y diseño.

Monica Armani

Diade

SUSPENSION

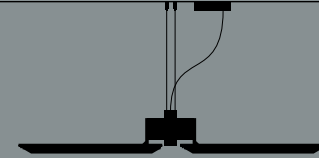

en A partition, a ceiling, that surprisingly becomes light. Rigorous linear design for the new Diade suspension lamp. After the success of Silenzio, Monica Armani continues her research on new technical lighting solutions that offer high levels of sound absorbing performance. A linear LED lamp for the workplace; a modular architectural feature capable of defining space and personalizing the context. The two "wing" panels can be positioned vertically or horizontally to create a partition or a large ceiling element. The two solutions solve lighting, sound absorbing needs and help to create a "ceiling sensation" with having to install dropped ceilings. The panels, thermoformed with sound-absorbing wadding, are shaped and marked by lines that have a simultaneously decorative and structural role. The LED light of Diade can be a direct light (vertical installation) or even direct/indirect (Horizontal installation).

it Una quinta, un plafone che sorprendentemente diventano luce. Design lineare e rigoroso per la nuova sospensione Diade. Dopo il successo riscontrato da Silenzio, Monica Armani prosegue la sua ricerca per nuove soluzioni illuminotecniche che offrano al contempo elevate prestazioni di fonoassorbimento. Una lampada a LED lineare dedicata ai luoghi di lavoro; un elemento architettonico modulare capace di definire lo spazio e personalizzare l'ambiente. I due pannelli "ali" possono essere posizionati verticali o orizzontali a creare una quinta o un grande plafone. Le due soluzioni proposte risolvono in un unicum luce, fonoassorbimento e il "ceiling" dello spazio, eliminando la necessità di controsoffitti. I pannelli, termoformati con ovatte altamente fonoassorbenti, sono plasmati e segnati da linee che hanno un scopo decorativo e strutturale al tempo stesso. La luce tecnica a LED, ideale per il lavoro, viene diretta verso il basso e verso l'alto dalla linea centrale, con possibilità di due ottiche a seconda delle esigenze.

de Eine Komposition oder eine Deckenleuchte wird überraschend zu Licht. Strenges und lineares Design zeichnet die neue Pendelleuchte Diade aus. Nach dem Erfolg von Silenzio setzt Monica Armani ihre Forschung nach neuen lichttechnischen Lösungen fort, welche auch bei der Schallabsorption hohe Leistung bieten. Eine lineare LED-Leuchte für Arbeitsräume: Dieses architektonische Modulelement definiert den Raum und personalisiert das Ambiente. Die beiden "Flügel"-Paneele können vertikal oder horizontal positioniert werden, um eine Komposition oder eine große Deckenleuchte zu gestalten. Die beiden vorgeschlagenen Lösungen verschmelzen zu Lichteinheit, Schallabsorption und "Ceiling" im Raum und heben die Notwendigkeit einer Zwischendecke auf. Die Paneele sind mit äußerst schallabsorbierender Watte thermogeformt und durch Linien gestaltet und geprägt, die zugleich strukturellen und dekorativen Zweck haben. Das technische LED-Licht eignet sich hervorragend zum Arbeiten. Es wird von der Mittellinie nach unten gerichtet und entsprechend den Bedürfnissen können zwei Lichtbündel ausgerichtet werden.

fr Une coulisse, un plafond qui deviennent tout à coup une source de lumière. Un design linéaire et rigoureux distingue la nouvelle suspension Diade. Après le succès de Silenzio, Monica Armani poursuit sa recherche en quête de nouvelles solutions d'éclairage permettant des performances d'insonorisation élevées. Une lampe à LED linéaire, dédiée aux lieux de travail; un élément architectural modulaire qui définit l'espace et personnalise l'ambiance. Les deux panneaux en forme « d'ailes » peuvent être placés verticalement, ou horizontalement, pour créer une coulisse, ou un grand plafond. Ces deux solutions résolvent les problèmes d'insonorisation et du plafond de l'espace par la réalisation d'un unicum fait de lumière, sans qu'il faille appliquer un faux plafond. Thermoformés avec de l'ouate et caractérisés par un niveau d'insonorisation très élevé, les panneaux sont moulés et arborent des lignes qui ont un but décoratif et structurel à la fois. Idéale pour le travail, la lumière technique à LED est dirigée vers le bas et vers le haut à partir de la ligne centrale en offrant deux optiques selon les besoins.

es Un bastidor, un plafón que sorprendentemente se transforman en luz. Diseño lineal y riguroso para la nueva suspensión Diade. Después del éxito de Silenzio, Monica Armani sigue su investigación de nuevas soluciones de luminotecnica que ofrezcan al mismo tiempo elevadas prestaciones de insonorización. Una lámpara de LED lineal dedicada a los lugares de trabajo; un elemento arquitectónico modular capaz de definir el espacio y personalizar el ambiente. Los dos paneles "alas" pueden colocarse en vertical u horizontal para crear un bastidor o un gran plafón. Las dos soluciones propuestas resuelven en un solo producto luz, insonorización y el techo del espacio eliminando la necesidad de instalar un cielo falso. Los paneles, termoformados con acolchados altamente insonorizantes, se plasman y marcan con líneas que tienen una finalidad decorativa y estructural al mismo tiempo. La luz técnica de LED, ideal para el trabajo, la dirige hacia abajo y hacia arriba la línea central con la posibilidad de dos ópticas según las exigencias.



Chromatic Journey

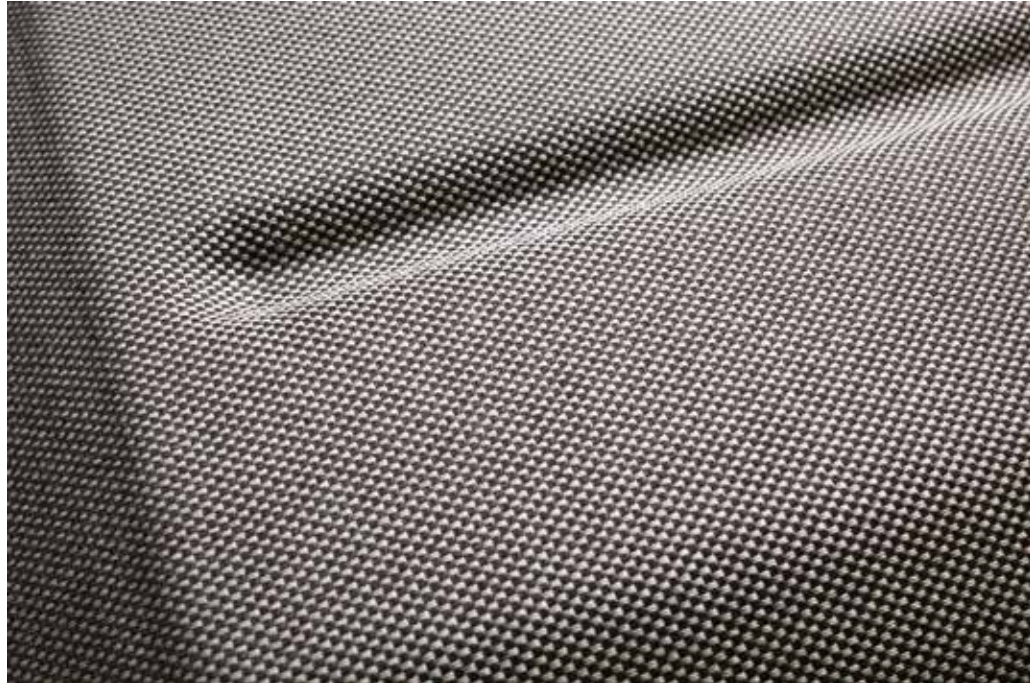

Structure finishes



white/blue



white/black



white/beige

EN The fabric of the panels complies with regulations for workspaces and public facilities and it is available in three different colors which generates a particularly refined couture effect . Diade is a technical fixture of great visual impact, with an evocative image, on or off, to adds character and warmth to any space in a unique way.

IT Il tessuto di rivestimento di Diade, che risponde alle normative per gli spazi di lavoro e pubblici, è disponibile in tre colori che creano un effetto couture particolarmente raffinato. Diade è una lampada tecnica di forte impatto e particolarmente suggestiva che, sia spenta che accesa, è in grado di definire e scaldare uno spazio in modo unico.

DE Der Bezugsstoff erfüllt die Vorschriften für den Arbeitsbereich und für öffentliche Räume und ist er in drei Farbpaletten erhältlich und erzeugt eine besonders anspruchsvolle Couture. Diade ist eine besonders stimmungsvolle, technische Leuchte von großer Wirkung. Sowohl ausgeschaltet als auch eingeschaltet vermag sie einen Raum einzigartig und charakteristisch zu definieren und zu erwärmen.

FR Le tissu de revêtement de Diade, qui est conforme à toutes les réglementations en matière de lieux publics et de travail, est disponible en trois couleurs qui créent un effet couture particulièrement raffiné. Diade est un luminaire technique très suggestif et à fort impact. Allumé ou éteint, il est en mesure de définir un espace et de créer une atmosphère chaude sans pareil.

ES El tejido de revestimiento de Diade, que responde a todas las normativas para los espacios de trabajo y públicos, está disponible en tres colores que crean un efecto de alta costura especialmente refinado. Diade es una lámpara técnica de fuerte impacto y especialmente suggestiva que, tanto apagada como encendida, es capaz de definir y dar calidez a un espacio de una forma única.

Technical and acoustic specifications

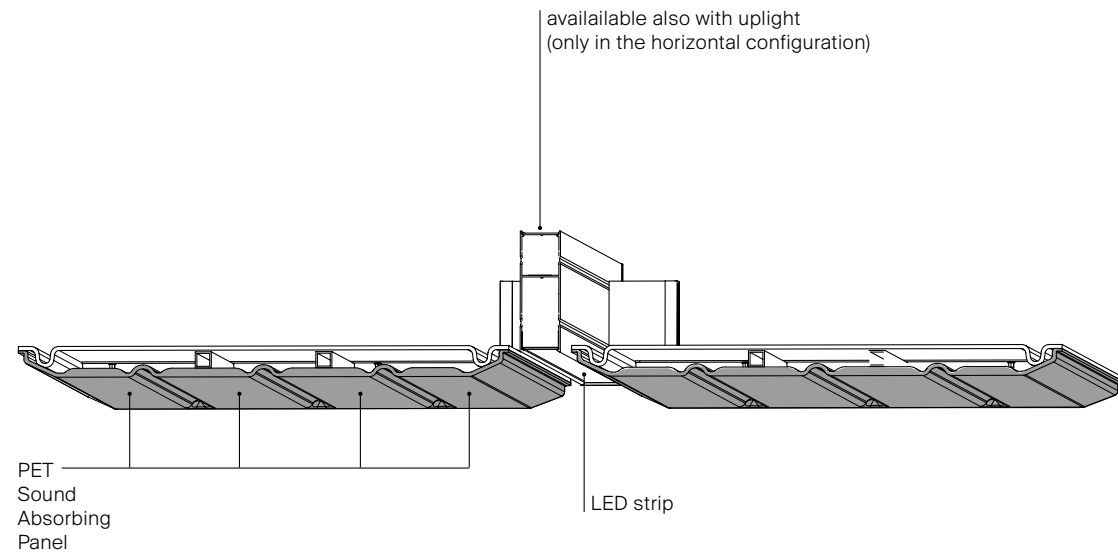

Diade 120 cm

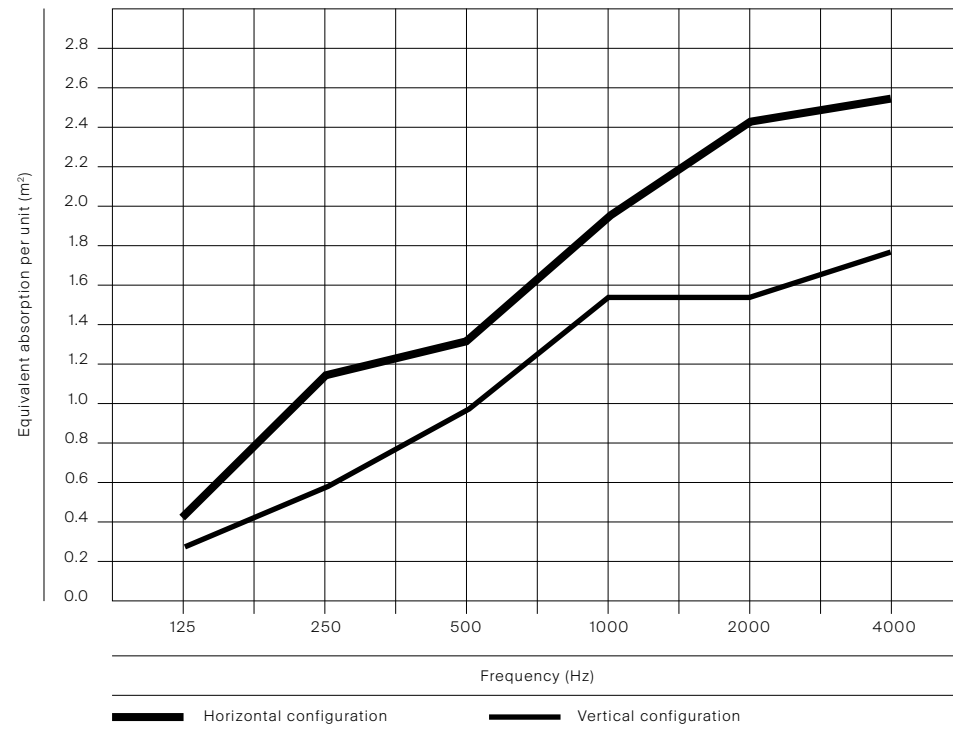

Sound Absorption of Diade 120 cm based on test results in compliance with EN ISO 335:2003 "measurement of sound absorption in a reverberation room".

EN Background noise – particularly modern buildings – can often become uncomfortably loud, due to the predominance of sound-reflecting materials. The design of the room (shape, furnishings, surface finishes, etc.) influences the extent to which the sound level decreases in relation to distance. An unfurnished room with sound reflective surfaces, such as a church, is perceived as being more reverberant than a well-furnished living room. The materials used in Diade provide sound absorption and prevent acoustic overlap, particularly in the case of human voice, which lies in the frequency range between 200 and over 3000 hertz (Hz). In this area the lamp achieves its best results thanks to its structure, which makes the sound waves “bounce” inside it. A conversation taking place immediately below the lamp Diade benefits from a high level of speech clarity, and general comfort is guaranteed.

IT I rumori di sottofondo, soprattutto nelle architetture contemporanee, possono essere molto fastidiosi a causa della predominanza di materiali e superfici che riflettono i suoni. La progettazione degli ambienti (forme, arredi, finiture delle superfici, ecc.) influenza la misura in cui il livello acustico decresce in rapporto alla distanza. Un locale non arredato e con superfici di scarso assorbimento acustico, come ad esempio una chiesa, viene percepito con maggior riverbero rispetto a un ambiente arredato. I materiali utilizzati per le lampade Diade garantiscono un elevato assorbimento acustico e diminuiscono il rimbombo sonoro, in particolare collegato alla voce umana che ha un range di frequenza che varia tra 200 e 3000 Hertz (Hz). In questo range le lampade Diade sono molto efficaci grazie alla loro struttura che cattura le onde sonore. Le sospensioni Diade producono una elevata chiarezza del parlato e generano un comfort acustico diffuso.

DE Hintergrundlärm, insbesondere in modernen, funktionalen Gebäudebereichen, kann aufgrund der Schallreflektion durch die erwendeten Materialien häufig unangenehm laut sein. Der Raumwurf (seine Form, die Ausstattung, die Art der Oberflächen usw.) hat Einfluss darauf, ab welcher Entfernung der Lärmpegel geringer wird. Ein leerer Raum mit harten Flächen, beispielsweise eine Kirche, wird als stärker hallend wahrgenommen als ein gut eingerichtetes Wohnzimmer. Die Materialien, aus denen Diade besteht, sorgen für Schallabsorption und Überschneidung der Schallwellen, insbesondere der menschlichen Stimme, die in einem Frequenzbereich zwischen 200 bis etwas mehr als 3000 Hertz (Hz) liegt. Ihre beste Leistung erzielt die Lampe dank ihrer Struktur, an der die Schallwellen innen abprallen, in diesem Bereich. Gespräche, die direkt unter der Lampe Diade stattfinden, zeichnen sich durch die gute Sprachverständlichkeit und allgemeinen Hörkomfort aus.



FR Les bruits de fond, surtout dans les architectures contemporaines, peuvent résulter très gênantes à cause de l'abondance de matériaux et de surfaces sur lesquels les sons rebondissent. La conception des locaux (les formes, la décoration, les finitions des surfaces, etc.) influe sur la décroissance du niveau acoustique par rapport à la distance. Un local presque vide et avec des surfaces qui absorbent peu les sons, comme par exemple une église, fonctionnera plus comme caisse de résonance qu'un espace meublé et décoré. Les matériaux utilisés pour les lampes Diade garantissent une absorption acoustique élevée et limitent le résonnement sonore, en particulier celui qui est généré par la voix humaine dont la fréquence varie de 200 à 3000 Hertz (Hz). Pour cet écart de fréquence, les lampes Diade sont particulièrement efficaces grâce à leur structure qui capture les ondes sonores. Les suspensions Diade confèrent une clarté élevée aux conversations et génèrent un confort acoustique diffus.

ES Los ruidos de fondo, sobre todo en la arquitectura contemporánea, pueden ser muy molestos a causa del predominio de materiales y superficies que reflejan los sonidos. La planificación de los ambientes (formas, decoraciones, acabados de las superficies, etc.) influye en la medida en que el nivel acústico decrece en relación a la distancia. En un local no decorado y con superficies de escasa absorción acústica, como por ejemplo una iglesia, se percibe una mayor reverberación que en un ambiente decorado. Los materiales utilizados para las lámparas Diade garantizan una elevada absorción acústica y disminuyen la resonancia sonora, en especial en relación con la voz humana, que tiene un rango de frecuencias que varía entre los 200 y los 3.000 Hz. En este rango, las lámparas Diade son muy eficaces gracias a su estructura, que captura las ondas sonoras. Las suspensiones Silenzio producen una elevada claridad del habla y generan una comodidad acústica difusa.

Diade application

1

Model of application: call center and study room

Location analysis:

A workspace where several people speaking need physical isolation to be concentrated, sensible control of sound propagation + effective control of light too.

Solution:

Diade is a perfect solution that brings the sound control where needed, guarantying pleasant light and anti-glare effect on working areas.

2

Room data

L = 15 m
W = 10 m
H = 4 m

Lighting source used

LED module 29W (uplight)
LED module 54W (downlight)

Fixtures installation

1 Diade every four position

Illuminance average

Post (average value) 480 lx

3

Before: Time of reverberation* 2,27 s

After: (+ 12 Diade)

Time of reverberation 1,33 s

Decrease of reverberation: about 41%* **

* Measuring reverberation time allows to calculate total sound absorption. Reverberation time varies according to the frequency. If reverberation time is too long, the space can have echoes and rumbles.

** The data is always approximate: the software doesn't take in consideration the position of the speaker and the position of absorbent surfaces.

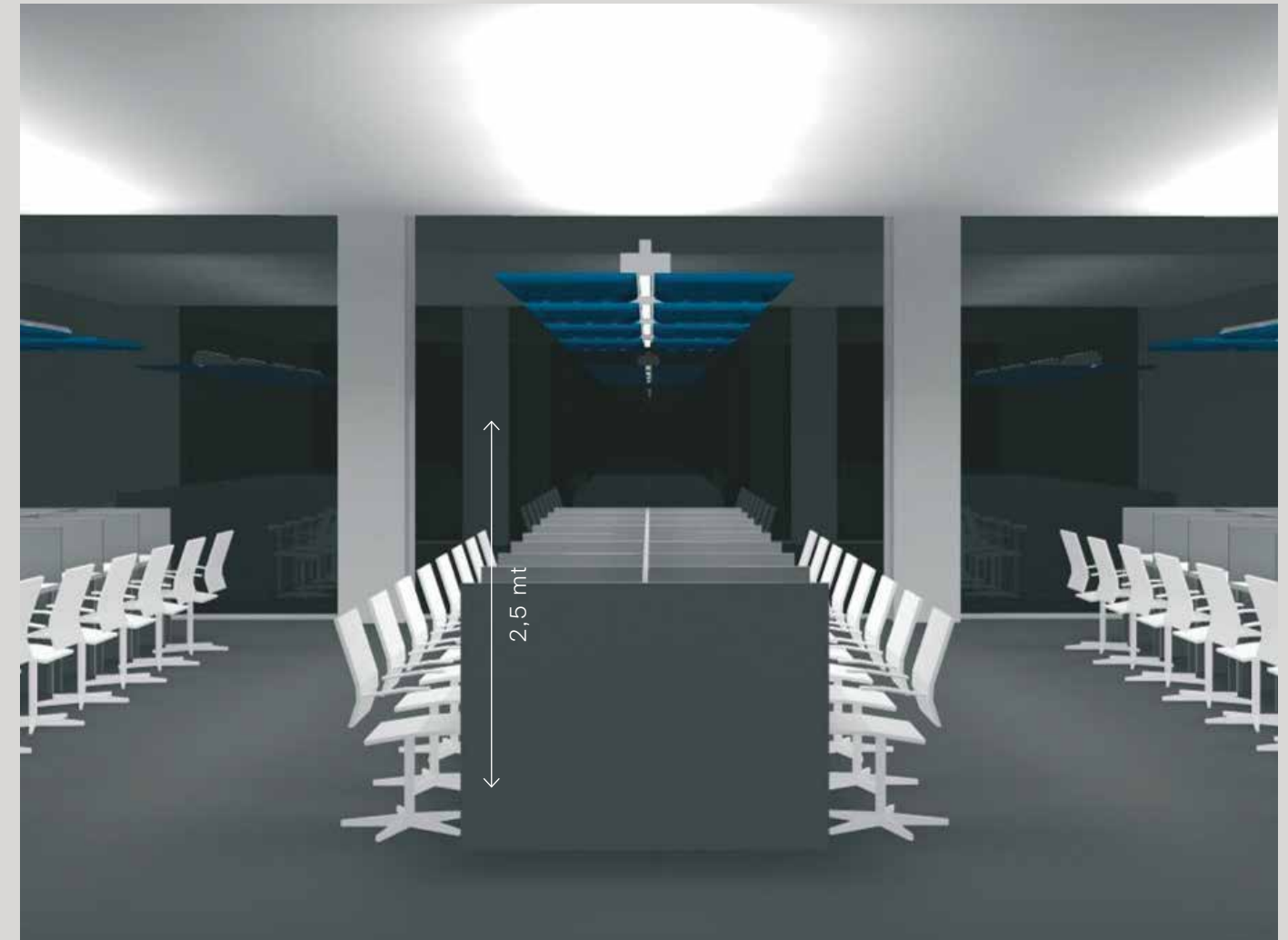



Vertical version

Panels 120 cm
weight 12,0 Kg
Panels 180 cm
weight 18,0 Kg

dimmable
push/DALI

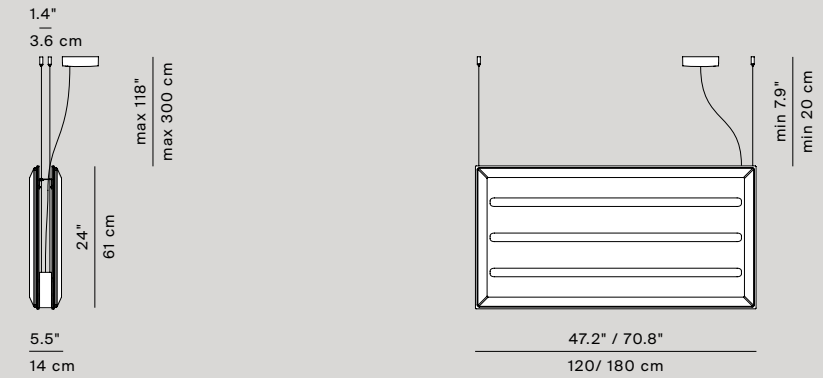

Horizontal version

Panels 120 cm
weight 12,0 Kg
Panels 180 cm
weight 18,0 Kg

dimmable
push/DALI

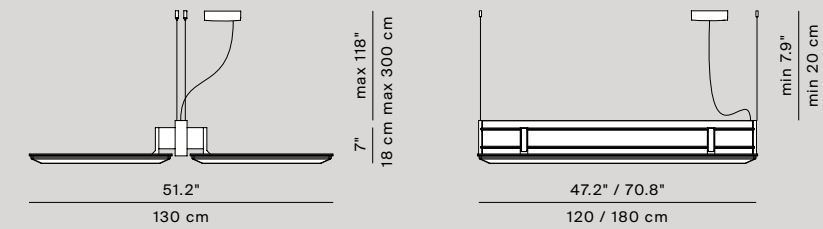

D93/5 - D93/7

Kit 4 supports (120 cm)
or 6 supports (180 cm)
positioning vertical panels



D93/6 - D93/8

Kit 4 supports (120 cm)
or 6 supports (180 cm)
positioning horizontal panels



Light source dimmable

D93SDDC / D93SDIC
D93SFIC

(direct version) LED 54W* 3000K, (direct/indirect version) 54W* + 29W* 3000K A++
direct with anti-glare optics (UGR < 19) / indirect version 54W* + 29W* 3000K A++

D93SDDL / D93SDIL
D93SFIL

(direct version) LED 80W* 3000K, (direct/indirect version) 80W* + 46W* 3000K A++
direct with anti-glare optics (UGR < 19) / indirect version 80W* + 46W* 3000K A++

Materials

Lamp body in aluminium, sound absorbing panel in molded PET

Structure finishes

 Natural grey
aluminium

Panel finishes

 White /
blue  White /
black  White /
beige

Insulation class

  **CE**

* Power consumption by device

Diego Sferrazza

Farel

SUSPENSION

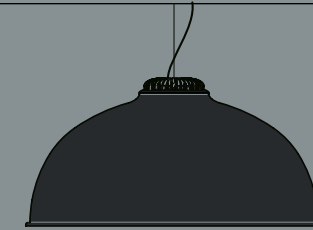

en For the first time in the Luceplan catalogue, Farel introduces an iconic dome structure, a neutral geometric form proposed in sound-absorbing thermoformed material with outer fabric cladding. The lamp can be personalized thanks to a combination of colors of the shade, ranging through cool, warm and neutral tones for the outside, combined with dark or pale hues for the inside.

it Farel introduce per la prima volta nel catalogo Luceplan l'iconica struttura a cupola, una geometria neutra proposta in materiale termoformato fonoassorbente rivestito di tessuto all'esterno. È possibile personalizzare la lampada grazie a una combinazione di colori del paralume che spaziano da tonalità fredde, calde e neutre per l'esterno, abbinate a toni scuri o chiari per l'interno.

de Farel ist die erste leuchte von luceplan mit ikonischer kuppelform – eine neutrale geometrische form aus thermisch geformtem material mit schallabsorbierendem bezug. Die leuchte bietet die möglichkeit individueller gestaltung über die schirmfarben: kalte, warme und neutrale farben für außen und dunkle oder helle für innen.

fr Farel présente, pour la première fois dans le catalogue Luceplan, la structure en dôme emblématique, une géométrie neutre proposée dans un matériau thermoformé insonorisant recouvert de tissu extérieur. Il est possible de personnaliser la lampe grâce à une combinaison de couleurs de l'abat-jour couvrant des teintes froides, chaudes et neutres pour l'extérieur, associées à des tons sombres ou clairs pour l'intérieur.

es Farel introduce por primera vez en el catálogo Luceplan la icónica estructura de cúpula, una geometría neutra propuesta de material termoformado fonoabsorbente revestido de tela por fuera. Es posible personalizar la lámpara gracias a una combinación de colores de la pantalla que van de tonos fríos, cálidos y neutros para el exterior, combinados con tonos oscuros o claros para el interior.



Technical and acoustical specifications

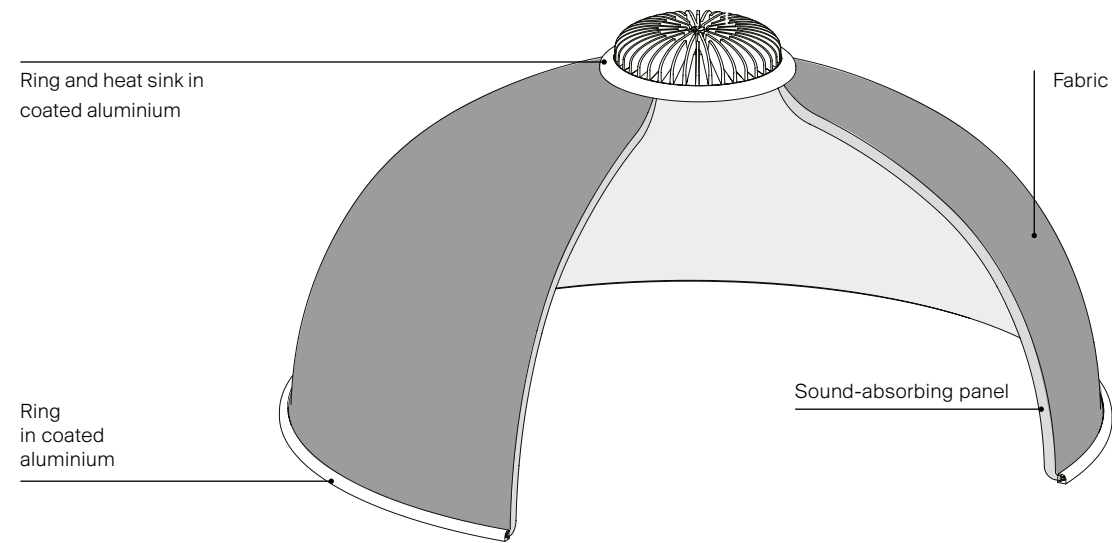

without Farel

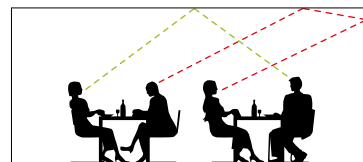

with Farel

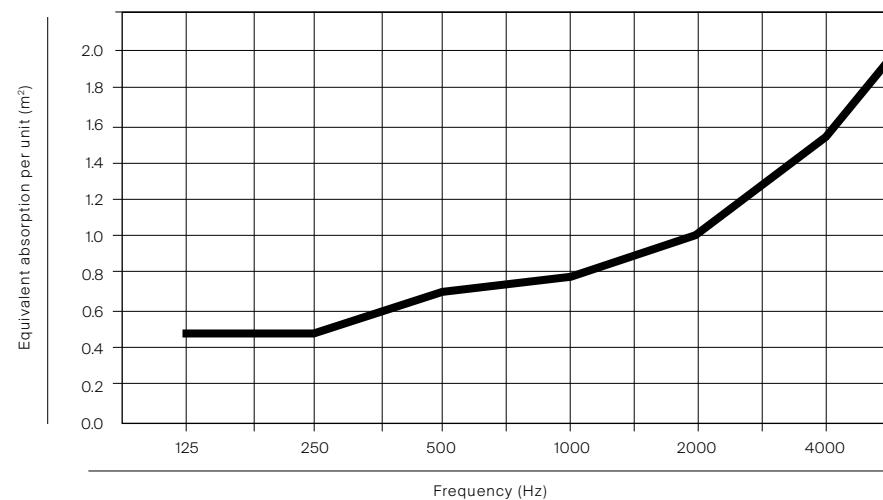
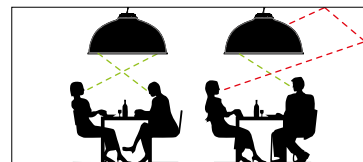

EN Farel suspension lamps combine high-quality lighting, acoustic comfort and refined design. The structure comes in a neutral geometric form proposed in sound-absorbing thermoformed material. The lamp can be personalized thanks to a combination of colors of the shade, ranging through cool, warm and neutral tones for the outside, combined with dark or white hues for the inside. The structure is outfitted at the top and along the lower diameter by two metal rings, available in different finishes, that can be freely fastened to the shade for complete customizing on the part of the user.

IT Le lampade a sospensione Farel coniugano un'illuminazione di alta qualità a comfort acustico e design raffinato. La struttura presenta una geometria neutra proposta in materiale termoformato fonoassorbente. È possibile personalizzare la lampada grazie a una combinazione di colori del paralume che spaziano da tonalità fredde, calde e neutre per l'esterno, abbinata a toni scuri o chiari per l'interno. La struttura è completata, nella parte superiore e sul diametro inferiore, da due anelli di metallo, disponibili in diverse finiture, che possono essere fissati liberamente al paralume per offrire all'utente le più ampie possibilità di personalizzazione.

DE Farel-Pendelleuchten verbinden Lichtqualität, akustischen Komfort und edles Design. Die neutrale geometrische Form gibt es auch in der Ausführung mit schallabsorbierendem Material. Die Leuchte bietet die Möglichkeit individueller Gestaltung über die Schirmfarben: kalte, warme und neutrale Farben für außen und dunkle oder helle für innen. Der Leuchenschirm trägt oben und unten je einen Metallring, der für die individuelle Gestaltung der Lampe in unterschiedlichen Ausführungen angeboten wird und nach Wunsch mit dem Schirm verbunden werden kann.

FR Les suspensions Farel combinent un éclairage de haute qualité, un confort acoustique et un design raffiné. La structure se présente sous une forme géométrique neutre proposée dans un matériau thermoformé insonorisant. Il est possible de personnaliser la lampe grâce à une combinaison de couleurs de l'abat-jour couvrant des teintes froides, chaudes et neutres pour l'extérieur, associées à des tons sombres ou clairs pour l'intérieur. La structure est équipée en haut et en bas du diamètre par deux anneaux en métal, disponibles en différentes finitions, qui peuvent être fixés librement à l'abat-jour pour une personnalisation complète de la part de l'utilisateur.



ES Las lámparas de suspensión Farel conjugan una iluminación de alta calidad con confort acústico y diseño sofisticado. La estructura posee una geometría neutra propuesta en material termoformato fonoabsorbente. Es posible personalizar la lámpara gracias a una combinación de colores de la pantalla que van de tonos fríos, cálidos y neutros para el exterior, combinados con tonos oscuros o claros para el interior. La estructura la completan, en la parte superior y en el diámetro inferior, dos anillos de metal, disponibles en varios acabados, que pueden fijarse libremente en la pantalla para ofrecerle al usuario las más amplias posibilidades de personalización.

Farel application

1

Model of application: meeting room

Location analysis:

Those kind of areas are useful for a reserved space where the quality of conversation is the main goal. A space for interaction with digital system as well as persons. A creative space.

Solution:

Focus the light on the desk surface, create a more snug space, juiced up by chromatics and material interactions between textile and metallic parts. The “dome effect” guarantee less sound dispersion and a better effective communication.

2

Room data

L = 6 m
W = 4 m
H = 3 m

Lighting source used

Led 23W 2700K

Fixtures installation

2 fixtures for 1 meeting table
1,6 m AFF

Illuminance average

Post (average value) 678 lx

3

Before: Time of reverberation* 0,9 s

After: (+ 2 Farel)

Time of reverberation 0,82 s

Decrease of reverberation: about 15%* **

* Measuring reverberation time allows to calculate total sound absorption. Reverberation time varies according to the frequency. If reverberation time is too long, the space can have echoes and rumbles.

** The data is always approximate: the software doesn't take in consideration the position of the speaker and the position of absorbent surfaces.



Colors combination



- External fabric **Light grey**
- Internal felt **Dark Grey**
- External fabric **Dark grey**
- Internal felt **White**
- External fabric **Rust**
- Internal felt **Dark Grey**
- External fabric **Aquamarine**
- Internal felt **White**



Technical data



D96

Farel

D96
dimmable

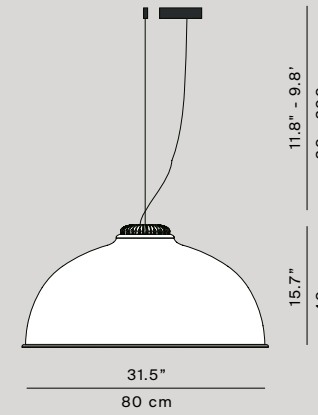

| | | | | |
|-------------------------------------|---|---|---|--|
| Light source | D96C + D96/1D | LED module 23W* 2700K dimmable push/DALI | EEL | |
| | D96C + D96/1DW | LED module 25W* 3000K dimmable phase cut / dim-to-warm | A++ | |
| Materials | Shade in acoustic material and flame retardant fabric Rings and heat sink in coated aluminium | | | |
| Rings and heat sink finishes | Matt Black | Matt Alu | Matt Brass | |
| External lampshade finishes | Light Grey | Dark Grey | Rust | Aquamarine |
| Internal lampshade finishes | Dark Grey | White | Dark Grey | White |
| Insulation class | □ V CE | | | |

* Power consumption by device

Odile Decq

Pétale

SUSPENSION

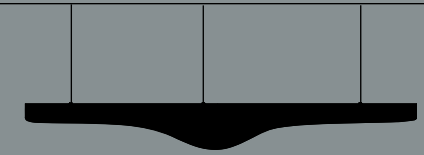

EN Pétale could be defined as a gracefully suspended petal that spreads soft, smooth white light. But the truly extraordinary feature of this object with an organic form is the way it absorbs sound. The body of the lamp, covered with white fabric, is made with a sound-absorbing panel. The dome that covers the light source is in polycarbonate. While it is ideal for use in compositions of multiple 'light petals' in large spaces for hospitality and socializing, Pétale also performs its multiple functions perfectly as a 'soloist' in any inhabited context.

IT Pétale si potrebbe definire un petalo sospeso con grazia che diffonde una luce bianca soffusa e ovattata. Ma la straordinaria prerogativa di questa lampada dalla forma organica, risiede nella sua capacità di assorbire il rumore. Il corpo lampada, rivestito con un tessuto bianco, è costituito da un pannello fonoassorbente. La cupola che ne regge la struttura è in policarbonato. Particolarmente indicata per composizioni in grandi spazi d'accoglienza e convivialità, Pétale svolge la sua molteplice funzione anche "singolarmente", in ogni contesto abitativo.

DE Pétale ließe sich als anmutig schwebendes Blütenblatt definieren, das blendfreies, weiches Licht abgibt. Das Besondere an dieser organisch geformten Leuchte ist aber ihre Fähigkeit, Schall zu schlucken. Der Leuchtenkörper besteht aus einem schallabsorbierenden Paneel und ist mit einem weißen textilen Überzug bespannt. Die Kuppel für die Aufhängung besteht aus Polycarbonat. Pétale eignet sich für Beleuchtungskombinationen in einer Umgebung mit großen Menschenansammlungen, lässt sich mit ihrer vielseitigen Funktion aber auch einzeln einsetzen in Wohnräumen.

FR Pétale: une lampe-pétale suspendue avec grâce qui diffuse une lumière blanche tamisée et ouatée. Mais la caractéristique extraordinaire de cette lampe de forme organique réside en sa capacité d'absorber le bruit. Le corps de la lampe, revêtu d'un tissu blanc, est constitué d'un panneau phono-absorbant. La coupole qui en soutient la structure est en polycarbonate. Particulièrement indiquée pour des compositions valorisant de grands espaces d'accueil et de convivialité, Pétale remplit ses multiples fonctions également en solo, dans un logement normal.

ES Pétale se podría definir como un pétalo suspendido con gracia que difunde una luz blanca velada y tenue. Pero la extraordinaria prerrogativa de esta lámpara de forma orgánica reside en su capacidad de absorber el ruido. El cuerpo de la lámpara, revestido con un tejido blanco, se compone de un panel fonoabsorbente. La cúpula que sujeta su estructura es de policarbonato. Particularmente indicada para composiciones en grandes espacios de acogida y convivencia, Pétale también lleva a cabo su función múltiple de manera «individual», en cada contexto habitacional.



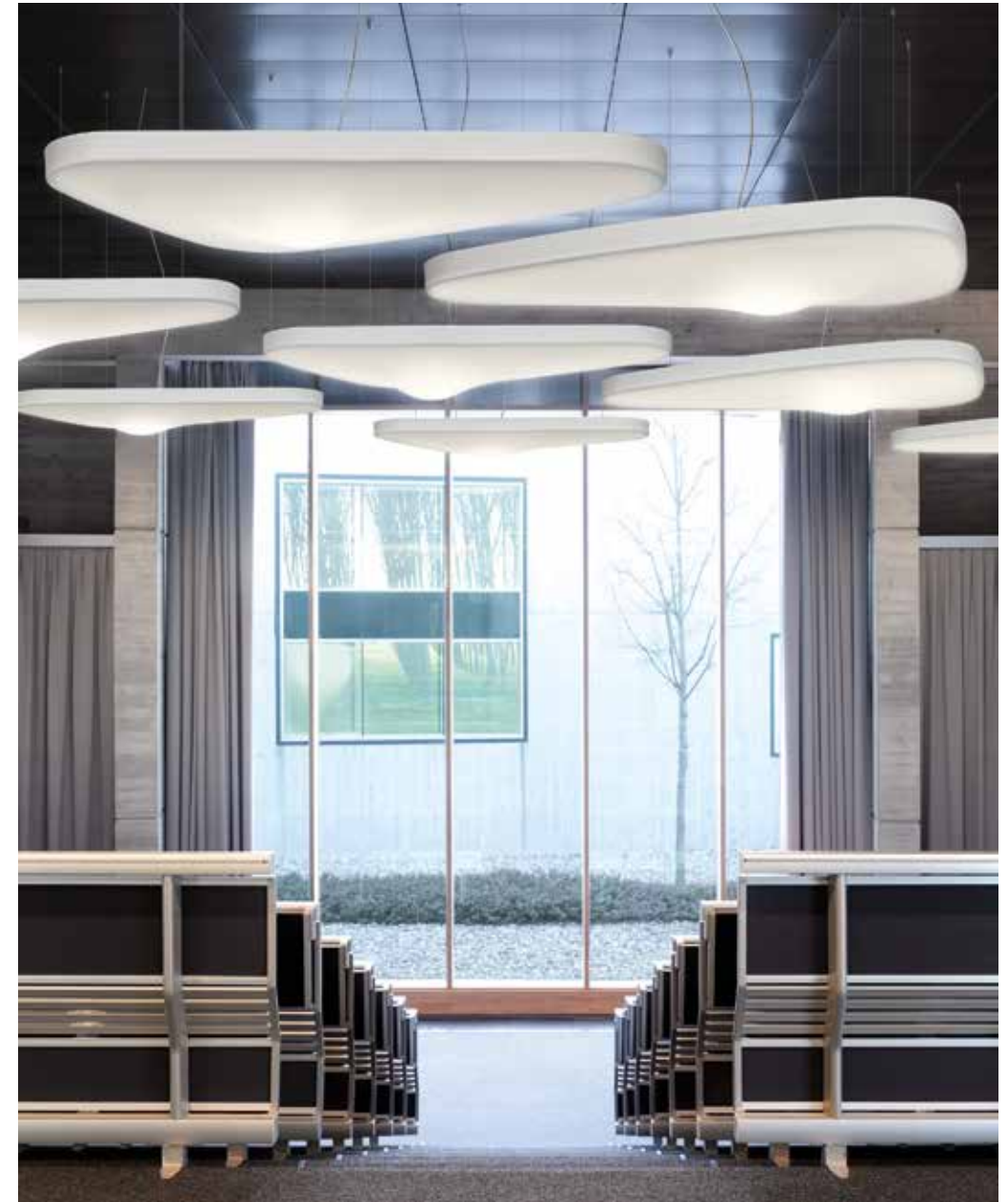

Technical and acoustical specifications

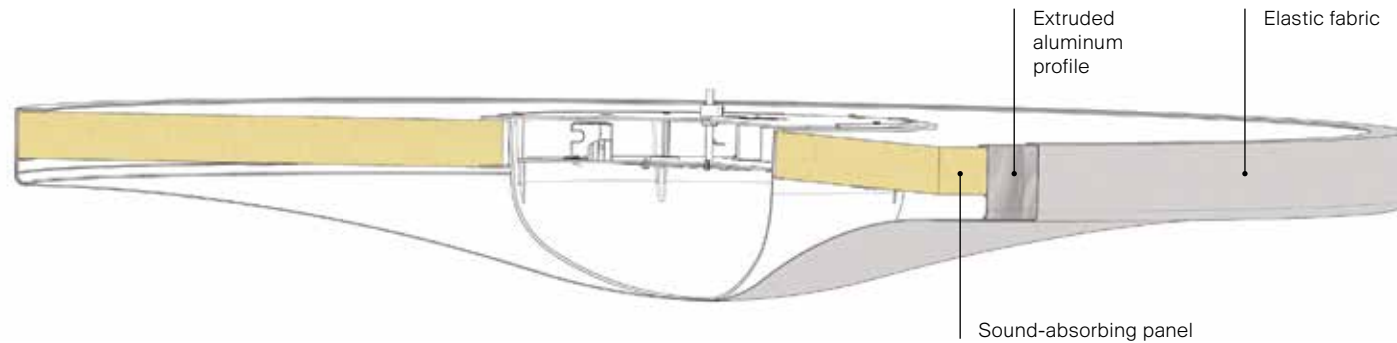

Sound absorbing panel

Environmental influence.
Granted the Nordic Swan eco-label.
Fully recyclable.

Fire safety

The glass wool core of the tiles is tested and classified as non-combustible according to EN ISO 1182.

The technology of Pétale is based on free suspended sound-absorbing units. Sound waves propagate through the fabric and penetrate inside the sound absorbing material, where their energy is reduced.

With Pétale, the sound waves are not just absorbed by the bottom surface but also by the top, which intercepts sound reflected by walls and ceilings.

without Pétale

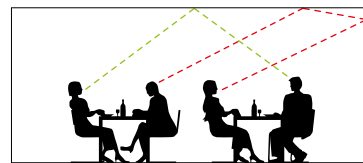

with Pétale

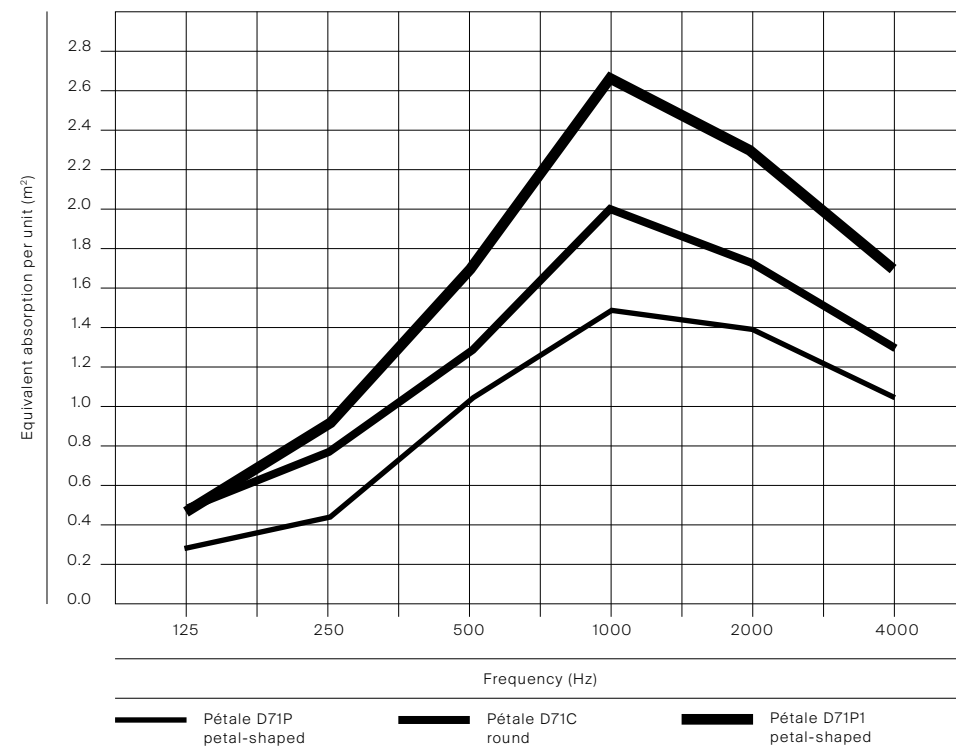
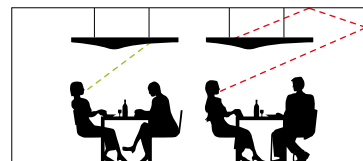

EN Background noise – particularly in modern buildings – can often be uncomfortably loud, due to the predominance of sound-reflecting materials. The design of the room (shape, furnishings, surface finishes, etc.) influences the extent to which the sound level decreases in relation to distance. An unfurnished room with sound reflective surfaces, such as a church, is perceived as being more reverberant than a well-furnished living room. The materials used in Pétale provide sound absorption and prevent acoustic overlap, particularly in the case of human voices, which lies in the frequency range between 200 and over 3000 hertz (Hz). In this area the lamp achieves its best results thanks to its structure, which makes the sound waves “bounce” inside it. A conversation taking place immediately below the lamp benefits from a high level of speech clarity, and general comfort is guaranteed.

IT I rumori di sottofondo, soprattutto nelle architetture contemporanee, possono essere molto fastidiosi a causa della predominanza di materiali e superfici che riflettono i suoni. La progettazione degli ambienti (forme, arredi, finiture delle superfici, ecc.) influenza la misura in cui il livello acustico decresce in rapporto alla distanza. Un locale non arredato e con superfici di scarso assorbimento acustico, come ad esempio una chiesa, viene percepito con maggior riverbero rispetto a un ambiente arredato. I materiali utilizzati per le lampade Pétale garantiscono un elevato assorbimento acustico e diminuiscono il rimbombo sonoro, in particolare collegato alla voce umana che ha un range di frequenza che varia tra 200 e 3000 Hertz (Hz). In questo range le lampade Silenzio sono molto efficaci grazie alla loro struttura che cattura le onde sonore. Le sospensioni Pétale producono una elevata chiarezza del parlato e generano un comfort acustico diffuso.

DE Hintergrundlärm, insbesondere in modernen, funktionalen Gebäudebereichen, kann aufgrund der Schallreflektion durch die verwendeten Materialien häufig unangenehm laut sein. Der Raumentwurf (seine Form, die Ausstattung, die Art der Oberflächen usw.) hat Einfluss darauf, ab welcher Entfernung der Lärmpegel geringer wird. Ein leerer Raum mit harten Flächen, beispielsweise eine Kirche, wird als stärker hallend wahrgenommen als ein gut eingerichtetes Wohnzimmer. Die Materialien, aus denen Pétale besteht, sorgen für Schallabsorption und Überschneidung der Schallwellen, insbesondere der menschlichen Stimme, die in einem Frequenzbereich zwischen 200 bis etwas mehr als 3000 Hertz (Hz) liegt. Ihre beste Leistung erzielt die Lampe dank ihrer Struktur, an der die Schallwellen innen abprallen, in diesem Bereich. Gespräche, die direkt unter der Lampe stattfinden, zeichnen sich durch die gute Sprachverständlichkeit und allgemeinen Hörkomfort aus.



FR Les bruits de fond, surtout dans les architectures contemporaines, peuvent résulter très gênantes à cause de l'abondance de matériaux et de surfaces sur lesquels les sons rebondissent. La conception des locaux (les formes, la décoration, les finitions des surfaces, etc.) influe sur la décroissance du niveau acoustique par rapport à la distance. Un local presque vide et avec des surfaces qui absorbent peu les sons, comme par exemple une église, fonctionnera plus comme caisse de résonance qu'un espace meublé et décoré. Les matériaux utilisés pour les lampes Pétale garantissent une absorption acoustique élevée et limitent le résonnement sonore, en particulier celui qui est généré par la voix humaine dont la fréquence varie de 200 à 3000 Hertz (Hz). Pour cet écart de fréquence, les lampes Silenzio sont particulièrement efficaces grâce à leur structure qui capture les ondes sonores. Les suspensions Pétale confèrent une clarté élevée aux conversations et génèrent un confort acoustique diffus.

ES Los ruidos de fondo, sobre todo en la arquitectura contemporánea, pueden ser muy molestos a causa del predominio de materiales y superficies que reflejan los sonidos. La planificación de los ambientes (formas, decoraciones, acabados de las superficies, etc.) influye en la medida en que el nivel acústico decrece en relación a la distancia. En un local no decorado y con superficies de escasa absorción acústica, como por ejemplo una iglesia, se percibe una mayor reverberación que en un ambiente decorado. Los materiales utilizados para las lámparas Pétale garantizan una elevada absorción acústica y disminuyen la resonancia sonora, en especial en relación con la voz humana, que tiene un rango de frecuencias que varía entre los 200 y los 3.000 Hz. En este rango, las lámparas Pétale son muy eficaces gracias a su estructura, que captura las ondas sonoras. Las suspensiones Pétale producen una elevada claridad del habla y generan una comodidad acústica difusa.

Pétale application

1

Model of application: office

Location analysis:

a pleasant workspace must guarantee a perfect balance between correct, uniform lighting of workspaces and a comfortable acoustic "situation" in which the noise produced inside the space is reduced to a minimum level.

Solution:

Pétale suspensions combine the technology of a fiberglass panel that absorbs the sound waves reflected by the room's surfaces with an integrated high-performance lighting module. The result is a comfortable lightscape and a pleasing acoustic sensation.

Room data

L = 6 m
W = 6 m
H = 4 m

Lighting source used

LED 40W
LED strip 18W

Fixtures installation

1 fixture every
2 workspace at 2,5 m

Illuminance average

Workspaces 362 lx

Before: Time of reverberation* 1,20 s

After: (+ 2 Pétale D71P1)

Time of reverberation 0,98 s

Decrease of reverberation: about 19%**

* Measuring reverberation time allows to calculate total sound absorption. Reverberation time varies according to the frequency. If reverberation time is too long, the space can have echoes and rumbles.

** The data is always approximate: the software doesn't take in consideration the position of the speaker and the position of absorbent surfaces.

2

3





Technical data

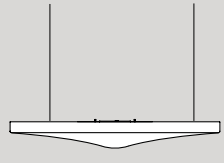
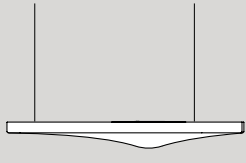
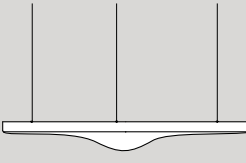
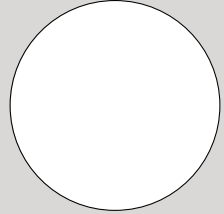
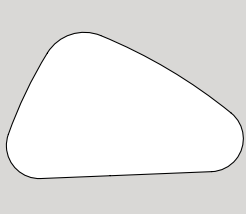
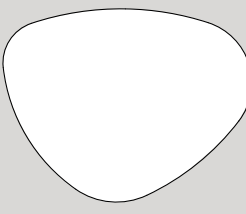
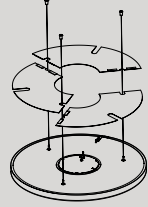
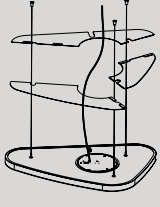
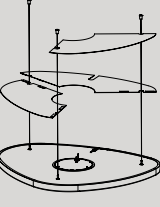

D71

Pétale

| | | | |
|---|---|--|---|
| D71CL weight 13,0 Kg D71PL weight 14,10 Kg D71PIL weight 16,50 Kg | D71CL  2.3" min 8" - max 118" 6 cm min 20 - max 300 cm | D71PL  2.3" min 8" - max 118" 6 cm 53.5" 136 cm | D71PIL  2.3" min 8" - max 118" 6 cm 60.8" 154,5 cm |
| |  47.3" 120 cm |  32.7" 83 cm |  47.2" 120 cm |
| Accessoires cover | D71/OAC for D71CL  | D71/OAP for D71PL  | D71/OAP1 for D71PIL  |
| Light source | D71PL LED 45W* 3000K push/DALI + 17W LED strip** | D71PIL LED 45W* 3000K push/DALI + 18W LED strip** | EEL A++ |
| | D71CL LED 45W* 3000K push/DALI + 18W LED strip** | | A++ |
| | D71PIL LED 45W* 3000K push/DALI + 21W LED strip** | | A++ |
| Materials | Aluminium structure and textile | | |
| Structure finishes | <input type="radio"/> White | | |
| Insulation class |  | | |

* Power consumption by device

** Not dimmable LED low power strip on inside for light accent

Projects



The Cargo

| | |
|-------------------|-------------------|
| CITY | Paris, France |
| ARCHITECT | Studio Odile Decq |
| LIGHTING DESIGNER | Studio Odile Decq |
| PHOTO | Roland Halbe |

read more: luceplan.com/products/acoustic



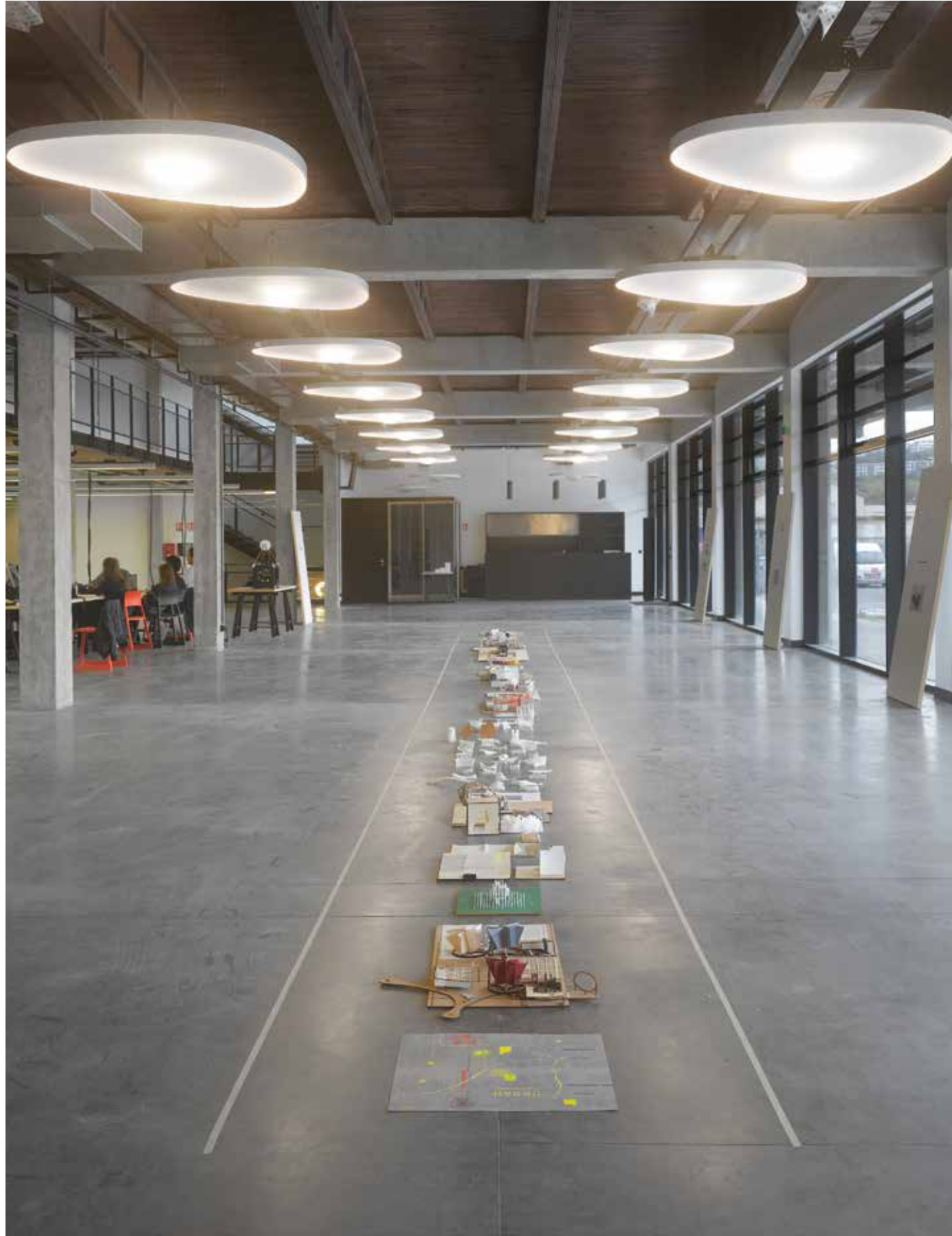

Projects



Confluence

| | |
|-------------------|-------------------|
| CITY | Lyon, France |
| ARCHITECT | Studio Odile Decq |
| LIGHTING DESIGNER | Studio Odile Decq |
| PHOTO | Roland Halbe |

read more: luceplan.com/products/acoustic

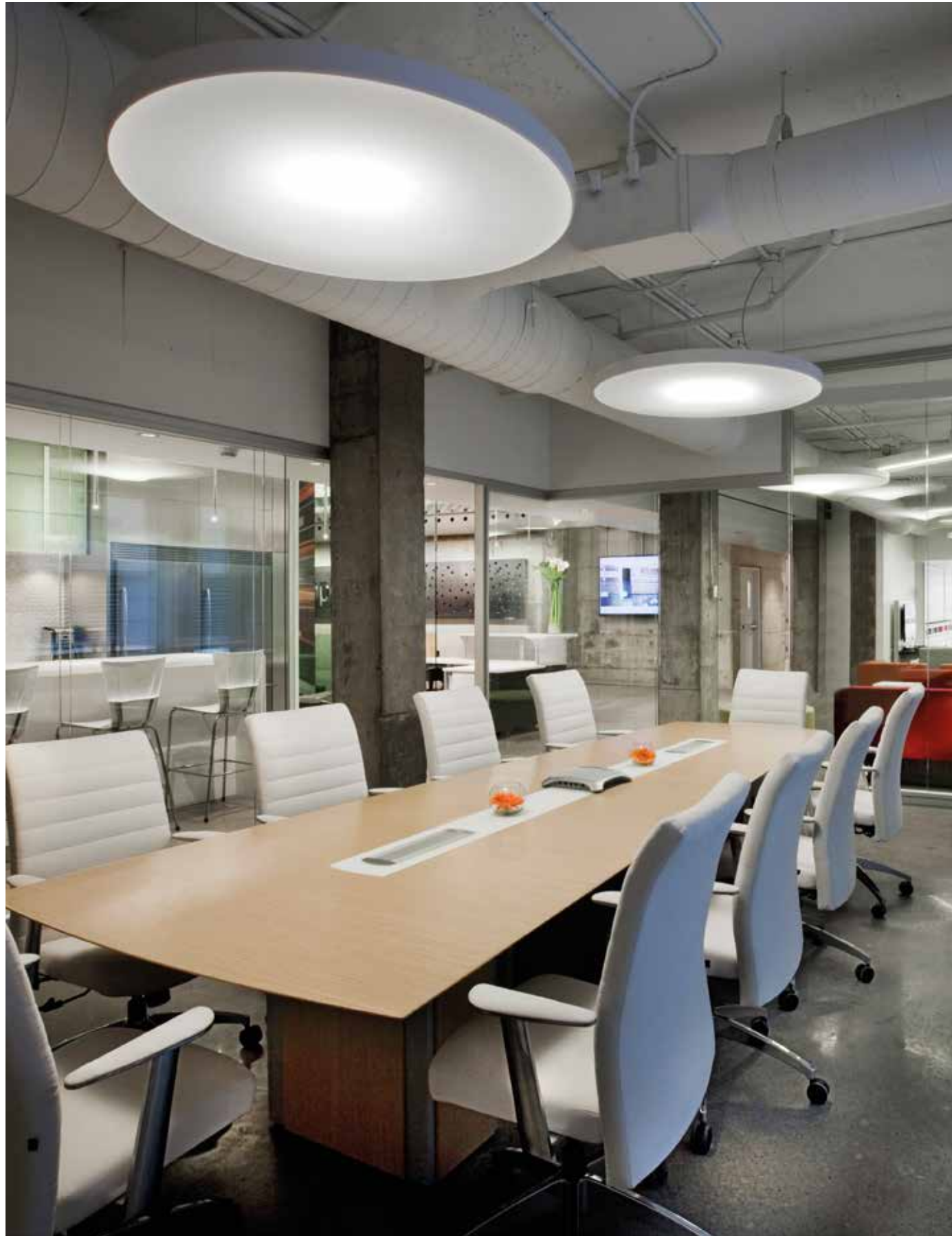

Projects



Artopex

| | |
|---------|-----------------------|
| CITY | Montreal, Canada |
| PROJECT | Lemay Studio Montreal |
| PHOTO | Langloisphoto |

read more: luceplan.com/products/acoustic

Projects



Deloitte

| | |
|-----------------|-------------------------------|
| CITY | Milan, Italy |
| LIGHTING DESIGN | Philips Lighting and Luceplan |
| PHOTO | Courtesy Signify Italy |

read more: luceplan.com/products/acoustic



Monica Armani

Silenzio

SUSPENSION

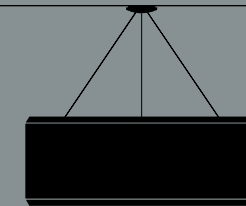

EN Silenzio by Monica Armani is a lighting system that combines furnishing solutions with high sound-absorbing performance for public and private spaces, with the beauty of fabrics and exceptional quality of light: a lighting system that decorates and personalizes spaces, the perfect expression of the interaction of technology and design.

IT Silenzio di Monica Armani è un sistema d'illuminazione che abbina soluzioni d'arredo ad elevate prestazioni di fonoassorbente per spazi pubblici e privati, una risposta progettuale di grandi capacità prestazionali che accompagna la bellezza dei tessuti alla qualità della luce: un'illuminazione "sartoriale" che arreda e personalizza l'ambiente, perfetta espressione del binomio tecnologia e design.

DE Silenzio, Monica Armani Lichtsystem, ist eine Kombination aus Einrichtungslösung mit Schallabsorption, Schönheit der Stoffe und hervorragender Lichtqualität: auf Maß geschneiderte Lichtlösungen, die Räume gestalten und dekorieren, ein perfekter Ausdruck von Technik und Design.

FR Silenzio de Monica Armani est un système d'illumination qui combine des solutions décoratives à des prestations de phono-absorption élevées pour les espaces publics et privés, une création caractérisée par de grandes capacités de prestation, par la beauté des tissus et par la qualité de la lumière: un éclairage "haute-couture" qui meuble et personnalise l'environnement, l'expression parfaite du binôme technologie-design.

ES Silenzio de Monica Armani Es un sistema de iluminación que combina soluciones decorativas con grandes capacidades de absorción acústica para espacios públicos y privados, una respuesta de diseño de elevadas prestaciones que une la belleza de los tejidos de a la calidad de la luz: una iluminación «artesanal» que decora y personaliza el ambiente, perfecta expresión del binomio tecnología y diseño.



Chromatic Journey

Standard colours



EN The Silenzio fixture is covered in grisaille-type fabric featuring material and elegant texture. The collection comes in four colours with matching hues and other colour ranges are also available in support of the customer's choice to customise the suspensions in a "chromatic journey".

IT La lampada Silenzio è ricoperta dal tessuto con un aspetto "grisaglia" e una texture dalla mano materica ed elegante. Per la collezione sono stati abbinati cinque colori in tono fra loro e sono state effettuate ulteriori selezioni cromatiche per supportare la scelta del cliente nella personalizzazione delle sospensioni in una sorta di "viaggio cromatico".

DE Silenzio ist die schallabsorbierende Oberfläche der Leuchte mit Stoff bezogen, mit seiner grisailleartigen, rau-eleganten Optik. Für die Kollektion wurden fünf zueinander passende Farbnuancen kombiniert. Die zusätzlichen Farben wollen unsere Kunden bei ihrer individuellen Farbauswahl für den Bezug und die Abhängungen unterstützen und zu einer „chromatischen Reise“ einladen.

FR La lampe est revêtu d'un tissu avec un aspect "en grisaille" et d'une texture élégante et substantielle. Pour la collection Silenzio, cinq couleurs dans les mêmes tonalités ont été employées, enrichies d'ultérieures sélections chromatiques pour répondre à tous les désirs de nos clients afin de personnaliser panneaux et suspensions en créant un véritable "voyage chromatique".

ES La lampara está recubierto del tejido con un aspecto de «grisalla» y una textura matérica y elegante. Para la colección Silenzio se han combinado cinco colores pertenecientes a la misma gama de tonos, si bien se han realizado además otras selecciones cromáticas para apoyar las preferencias del cliente en la personalización de paneles y suspensions, dentro de un «viaje cromatico».

Possible color schemes available upon request, for customized solutions

Green



Blue

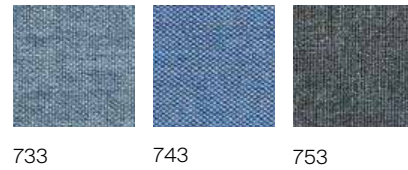

Green/beige

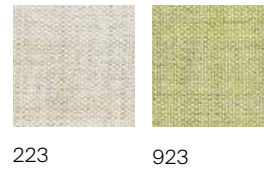

Pink/lilac



Orange

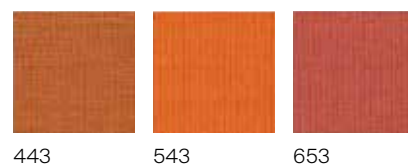

Grey



Technical and acoustical specifications

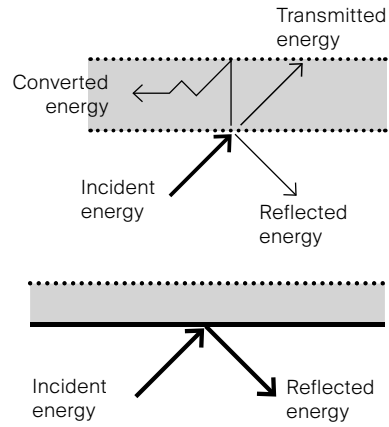

Sound Absorption of the three models (Silenzio Ø 90, 120 e 150 cm) based on test results in compliance with EN ISO 335:2003 "measurement of sound absorption in a reverberation room".

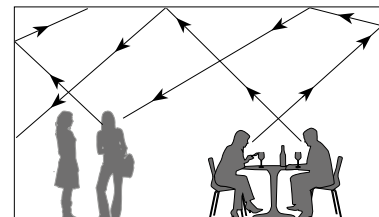

Room without Silenzio

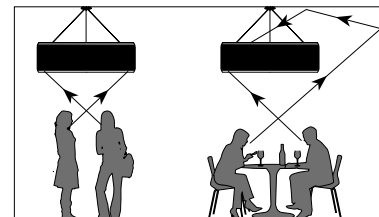

Room with Silenzio suspension. Place the lamp as close as possible to the sound source to intercept more sound waves. Double side absorbing power (inside/outside).

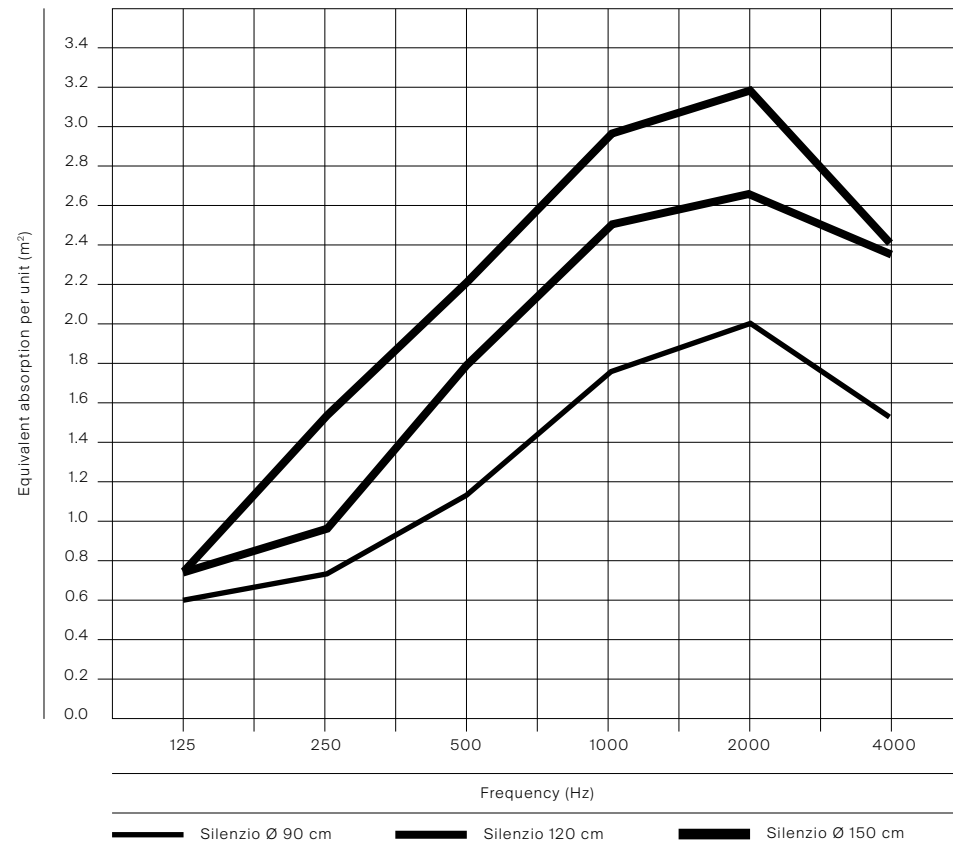
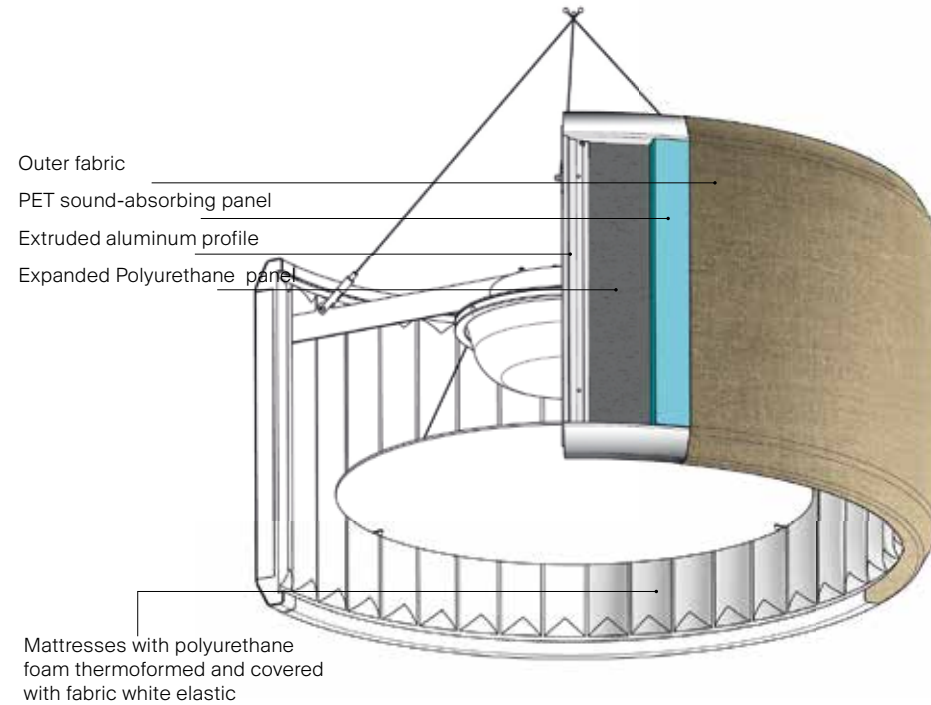

EN Background noise – particularly in modern buildings – can often be uncomfortably loud, due to the predominance of sound-reflecting materials. The design of the room (shape, furnishings, surface finishes, etc.) influences the extent to which the sound level decreases in relation to distance. An unfurnished room with sound reflective surfaces, such as a church, is perceived as being more reverberant than a well-furnished living room. The materials used in Silenzio provide sound absorption and prevent acoustic overlap, particularly in the case of human speech, which lies in the frequency range between 200 and over 3000 hertz (Hz). In this area the lamp achieves its best results thanks to its structure, which makes the sound waves “bounce” inside it. A conversation taking place immediately below the lamp benefits from a high level of speech clarity, and general comfort is guaranteed.

IT I rumori di sottofondo, soprattutto nelle architetture contemporanee, possono essere molto fastidiosi a causa della predominanza di materiali e superfici che riflettono i suoni. La progettazione degli ambienti (forme, arredi, finiture delle superfici, ecc.) influenza la misura in cui il livello acustico decresce in rapporto alla distanza. Un locale non arredato e con superfici di scarso assorbimento acustico, come ad esempio una chiesa, viene percepito con maggior riverbero rispetto a un ambiente arredato. I materiali utilizzati per le lampade Silenzio garantiscono un elevato assorbimento acustico e diminuiscono il rimbombo sonoro, in particolare collegato alla voce umana che ha un range di frequenza che varia tra 200 e 3000 Hertz (Hz). In questo range le lampade Silenzio sono molto efficaci grazie alla loro struttura che cattura le onde sonore. Le sospensioni Silenzio producono una elevata chiarezza del parlato e generano un comfort acustico diffuso.

DE Hintergrundlärm, insbesondere in modernen, funktionalen Gebäudebereichen, kann aufgrund der Schallreflektion durch die erwendeten Materialien häufig unangenehm laut sein. Der Raumentwurf (seine Form, die Ausstattung, die Art der Oberflächen usw.) hat Einfluss darauf, ab welcher Entfernung der Lärmpegel geringer wird. Ein leerer Raum mit harten Flächen, beispielsweise eine Kirche, wird als stärker hallend wahrgenommen als ein gut eingerichtetes Wohnzimmer. Die Materialien, aus denen Silenzio besteht, sorgen für Schallabsorption und Überschneidung der Schallwellen, insbesondere der menschlichen Stimme, die in einem Frequenzbereich zwischen 200 bis etwas mehr als 3000 Hertz (Hz) liegt. Ihre beste Leistung erzielt die Lampe dank ihrer Struktur, an der die Schallwellen innen abprallen, in diesem Bereich. Gespräche, die direkt unter der Lampe stattfinden, zeichnen sich durch die

FR Les bruits de fond, surtout dans les architectures contemporaines, peuvent résulter très gênantes à cause de l'abondance de matériaux et de surfaces sur lesquels les sons rebondissent. La conception des locaux (les formes, la décoration, les finitions des surfaces, etc.) influe sur la décroissance du niveau acoustique par rapport à la distance. Un local presque vide et avec des surfaces qui absorbent peu les sons, comme par exemple une église, fonctionnera plus comme caisse de résonance qu'un espace meublé et décoré. Les matériaux utilisés pour les lampes Silenzio garantissent une absorption acoustique élevée et limitent le résonnement sonore, en particulier celui qui est généré par la voix humaine dont la fréquence varie de 200 à 3000 Hertz (Hz). Pour cet écart de fréquence, les lampes Silenzio sont particulièrement efficaces grâce à leur structure qui capture les ondes sonores. Les suspensions Silenzio confèrent une clarté élevée aux conversations et génèrent un confort acoustique diffus.

ES Los ruidos de fondo, sobre todo en la arquitectura contemporánea, pueden ser muy molestos a causa del predominio de materiales y superficies que reflejan los sonidos. La planificación de los ambientes (formas, decoraciones, acabados de las superficies, etc.) influye en la medida en que el nivel acústico decrece en relación a la distancia. En un local no decorado y con superficies de escasa absorción acústica, como por ejemplo una iglesia, se percibe una mayor reverberación que en un ambiente decorado. Los materiales utilizados para las lámparas Silenzio garantizan una elevada absorción acústica y disminuyen la resonancia sonora, en especial en relación con la voz humana, que tiene un rango de frecuencias que varía entre los 200 y los 3.000 Hz. En este rango, las lámparas Silenzio son muy eficaces gracias a su estructura, que captura las ondas sonoras. Las suspensiones Silenzio producen una elevada claridad del habla y generan una comodidad acústica difusa.

Silenzio Application

1

Model of application: restaurant

Location analysis: the quality of a restaurant is a combination of different factors: quality of food, service and environment and a good quality of speech combined with acoustic comfort.

Solution: the Silenzio suspensions are the perfect solution because they are simple shapes which enrich the spaces thanks to the high quality of the textiles; they diffuse a comfortable light and provide high levels of acoustic absorption.

2

Room data:

L = 15 m
W = 7 m
H = 5,5 m

Different height
from 2,5 m to 2,9 m

Lighting source used:

LED module 40W

Fixtures installation:

5 x Silenzio Ø 90 cm
9 x Silenzio Ø 120 cm

Illuminance average:

Table (min) 180 lx
Table (max) 452 lx

3

Before: time of reverberation* 3,16 s

After: (with Silenzio) time of reverberation 1,55 s

Decrease of reverberation: about 51%**

Measuring reverberation time allows to calculate total sound absorption. Reverberation time varies according to the frequency. If reverberation time is too long, the space can have echoes and rumbles.

The data is always approximate: the software doesn't take in consideration the position of the speaker and the position of absorbent surfaces.



Technical data



D79

Silenzio

D79/90c

weight 17,0 Kg
dimmable push/DALI

D79/120c

weight 22,0 Kg
dimmable push/DALI

D79/150c

weight 29,0 Kg
dimmable push/DALI

D79/90c

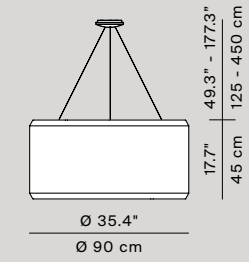

D79/120c

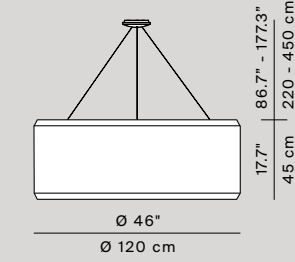

D79/150c

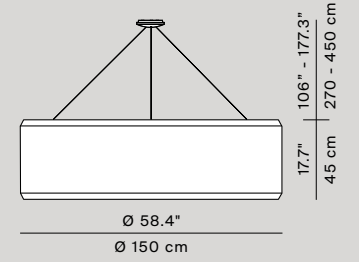

Accessoires

D79R/07 bottom screen

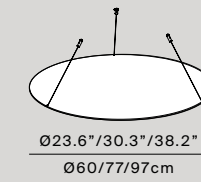

D79R/09 suspension kit

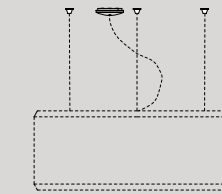

Light source

D79R/03

3 x LED E27
3 x max 105 HSGSA E27 energy saver
3 x 23/27W FB E27

A++ / A+ / A
D
A

D79R/10

LED module 45W* 3000K

A++

D79R/11

LED module 45W* 2700K

A++

Materials

Aluminium and steel structure and textile

Structure finishes

White

Textiles

Standard colours

133 152 242 252

Possible color schemes available upon request, for customized solutions

Green

412 912 942

Blue

733 743 753

Green/beige

223 923

Pink/lilac/blue

682 722 852

Orange

443 543 653

Grey

123

Insulation class



* Power consumption by device



Projects



Sedus Smart Office

| | |
|-----------------|-------------------------|
| CITY | Dogern, Germany |
| LIGHTING DESIGN | Consuline |
| PHOTO | Courtesy Sedus Stoll AG |

read more: [luceplan.com/products/acoustic](https://www.luceplan.com/products/acoustic)

Projects



Skyway Monte bianco

| | |
|---------|---|
| CITY | Courmayeur, Italy |
| PROJECT | Arch. Roberto Rosset, Danilo Montover, Aosta |
| PHOTO | Daniele Domenicali |

read more: luceplan.com/products/acoustic





Projects



Charlottehaven

| | |
|-------------------|---------------------------------|
| CITY | Copenhagen, Denmark |
| PROJECT | Lundgaard & Tranberg Arkitekter |
| LIGHTING DESIGNER | Luceplan Denmark |
| PHOTO | Egon Gade |

read more: luceplan.com/products/acoustic

Projects



Bullhorn

| | |
|---------|--|
| CITY | Boston, USA |
| PROJECT | Interior Architects (Boston location) Engineer: WB Engineers General Contractor: Columbia Construction |
| PHOTO | Robert Benson Photography |

read more: luceplan.com/products/acoustic

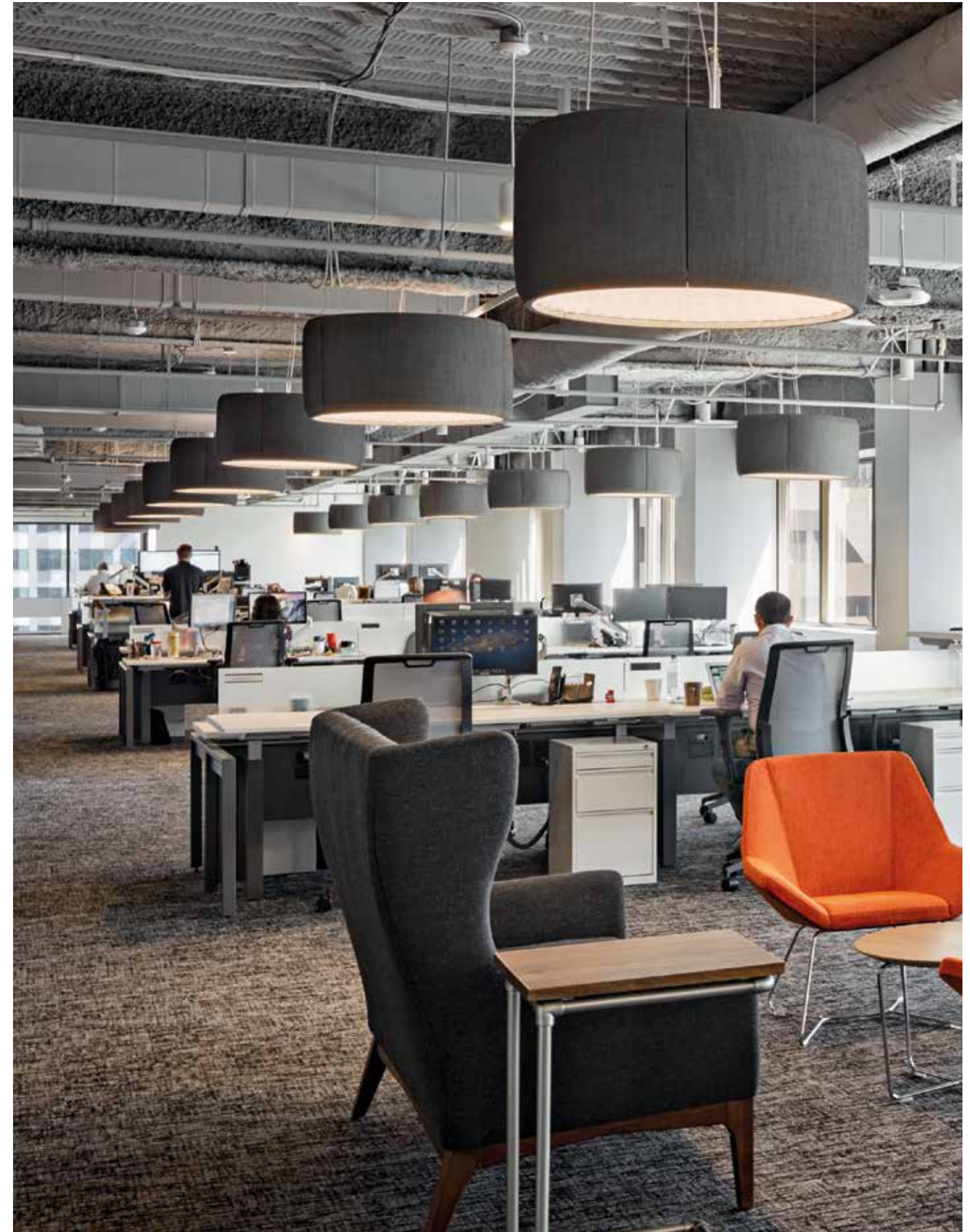



Projects



Shopify

| | |
|-------------------|--------------------------------|
| CITY | Ottawa, Canada |
| ARCHITECT | Line Box Studio, Andrew Reeves |
| LIGHTING DESIGNER | Dark Tools Toronto |
| PHOTO | Younes Bounhar |

read more: luceplan.com/products/acoustic

Projects



SpareBanken 1 SR

| | |
|---------|---|
| CITY | Stavanger, Norway |
| PROJECT | Architect/Interior architect: Arkidea AS Interior fittings: Senab Eikeland & TreProsjekt |
| PHOTO | Arne Bru Haug |

read more: [luceplan.com/products/acoustic](https://www.luceplan.com/products/acoustic)

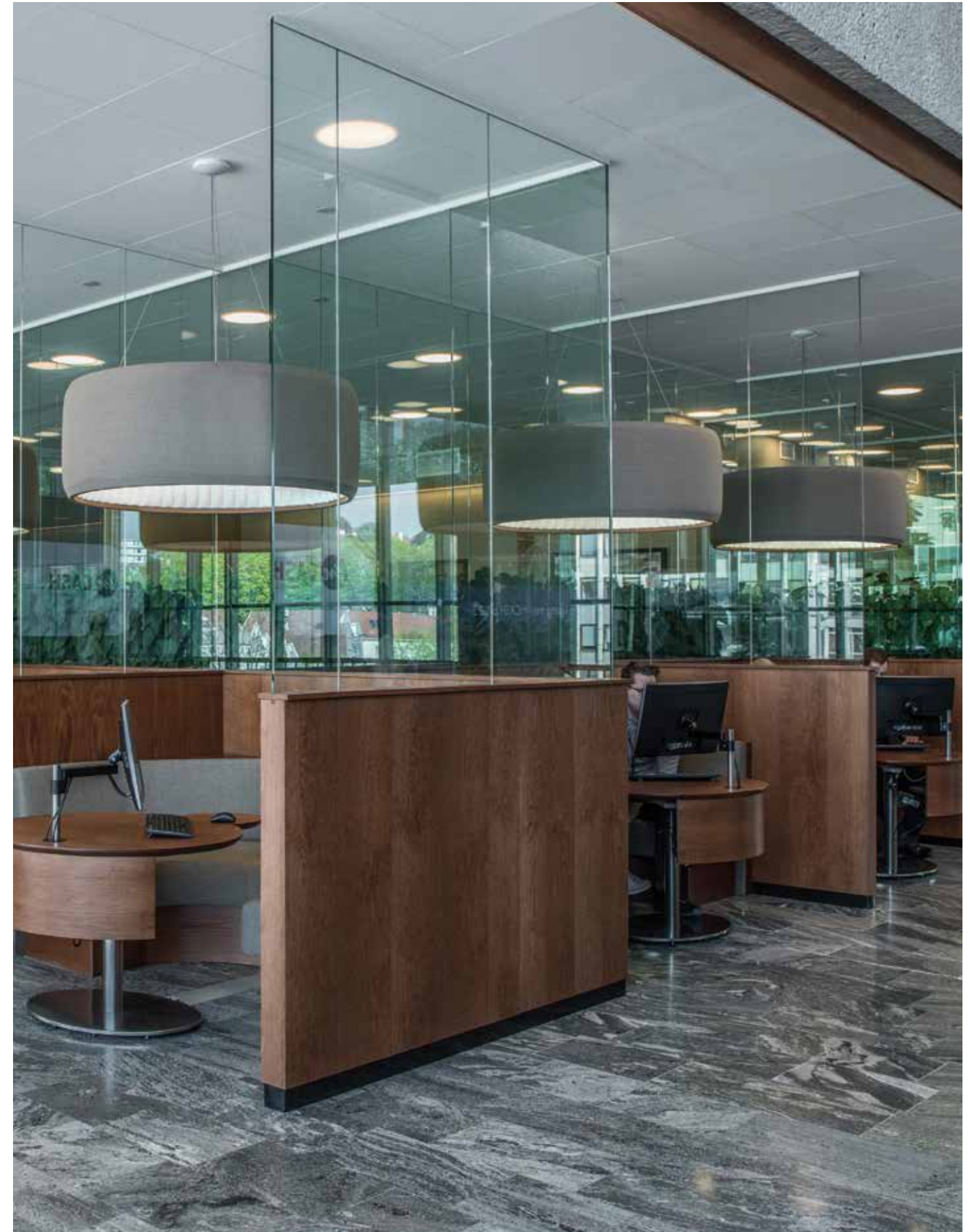

Stephen Burks

Trypta

SUSPENSION

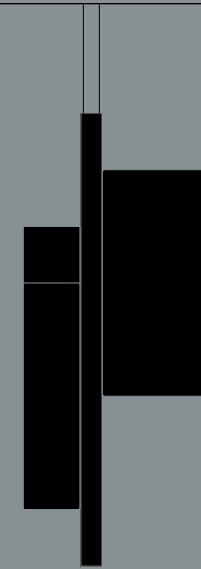

en Trypta is a system of suspension lamps that offers a combination of acoustic features and lighting performance in various dimensions and colors. The cylindrical aluminum body is equipped with two LED sources to provide both direct and indirect diffused light.

Three slots along the body of the lamp permit assembly of three acoustic panels positioned at 120°. The core of the panels is made of a high-performance soundproofing material, covered with an elegant fabric offered in different colors. The body of the lamp comes in two lengths while the panels are available in a range of different sizes, as it is possible to create varied configurations - flat, shifted and mixed - by combining panels in different measures and positions.

it Trypta è un sistema di lampade a sospensione che offre una combinazione di caratteristiche acustiche e prestazioni illuminotecniche in diverse dimensioni e colori. Il corpo cilindrico in alluminio è dotato di due sorgenti LED per un'emissione di luce sia diretta che indiretta e diffusa. Tre fessure situate sul corpo della lampada permettono il montaggio di tre pannelli acustici, posizionati a un angolo di 120°. Il nucleo dei pannelli, realizzato in materiale insonorizzante ad alte prestazioni, è rivestito di elegante tessuto, offerto in diversi colori. Il corpo della lampada è disponibile in due diverse lunghezze, mentre i pannelli sono acquistabili in un'ampia gamma di misure, con la possibilità di creare varie configurazioni, piane, sfalsate e miste, combinando pannelli di dimensioni e in posizioni differenti.

de Trypta ist ein System von Pendelleuchten in unterschiedlichen Größen und Farben, die Schallabsorbierung mit Lichtleistung verbinden. Der zylindrische Aluminiumkörper ist mit zwei LED-Leuchtmitteln für direktes und indirektes Licht bestückt. Über drei Schlitze im Lampenkörper sind drei Akustikpaneele im Winkel von 120° zueinander angebracht.

Das Innere dieser Paneele besteht aus hocheffizientem schallschluckendem Material, unter einem eleganten Stoffbezug in unterschiedlichen Farben. Die Lampe ist in zwei Längen erhältlich. Bei den Paneelen besteht die Möglichkeit, sie in unterschiedlichen Größen und Anordnungen (flach, versetzt, gemischt) zu kombinieren.

fr Trypta est un système de suspensions offrant une combinaison de caractéristiques acoustiques et de performances d'éclairage dans différentes dimensions et couleurs. Le corps cylindrique en aluminium est équipé de deux sources LED visant à fournir une lumière diffuse directe et indirecte. Trois fentes le long du corps de la lampe permettent l'assemblage de trois panneaux acoustiques positionnés à 120°. Le noyau des panneaux est constitué d'un matériau insonorisant à haute performance, recouvert d'un élégant tissu proposé en différentes couleurs.

Le corps de la lampe existe en deux longueurs tandis que les panneaux sont disponibles dans une gamme de tailles différentes, car il est possible de créer diverses configurations (plate, décalée et mélangée) en combinant des panneaux dans différentes mesures et positions.

es Trypta es un sistema de lámparas de suspensión que ofrece una combinación de características acústicas y prestaciones de luminotecnia en varios tamaños y colores. El cuerpo cilíndrico de aluminio está dotado de dos fuentes LED para una emisión de la luz tanto directa como indirecta y difusa. Tres fisuras situadas en el cuerpo de la lámpara permiten montar tres paneles acústicos, ubicados en un ángulo de 120°. El núcleo de los paneles, de material insonorizante de altas prestaciones, está revestido con una elegante tela propuesta en varios colores. El cuerpo de la lámpara está disponible en dos longitudes distintas, mientras que los paneles se pueden adquirir de una amplia gama de medidas, con la posibilidad de crear varias configuraciones, planas, escalonadas y mixtas, combinando paneles de varios tamaños y en posiciones distintas.



Chromatic map

Standard collection



01 Light grey

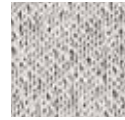

02 Medium grey

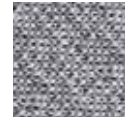

03 Dark grey



Solid collection



06 Peach



15 Orange



19 Mustard



29 Brick

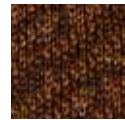

31 Brown

EN Trypta adapts perfectly to any space thanks to two separately activated light sources connected to the extremities of a central column, to provide both direct and indirect lighting. Its decorative character is underscored by the panels clad in flame-retardant knit fabric, giving Trypta a unique personality.

IT Trypta si adatta perfettamente a ogni ambiente grazie a due sorgenti luminose con accensioni separate collocate alle estremità del corpo centrale, in grado di fornire una diffusione della luce sia diretta che indiretta. Il suo carattere decorativo è rimarcato dai pannelli rivestiti in tessuto flame retardant filato a maglia, che le attribuiscono personalità e unicità.

DE Trypta passt sich perfekt an jede Umgebung an, dank zweier Lichtquellen mit getrennten Einstellungen an den Enden des Zentralkörpers, die sowohl direktes als auch indirektes Licht streuen können. Ihr dekorativer Charme wird durch die mit schwer entflammbarem Strickgewebe überzogenen Blenden betont, die ihr Persönlichkeit und Einzigartigkeit verleihen.

FR Trypta s'adapte parfaitement à tout environnement grâce à deux sources lumineuses à allumages séparés situés aux extrémités du corps central, qui diffusent la lumière de manière directe et indirecte. Son caractère décoratif est souligné par les panneaux recouverts d'un tissu en maille ignifuge qui lui confèrent personnalité et originalité.

ES Trypta se adapta perfectamente a cualquier ambiente gracias a dos fuentes de luz con encendidos independientes situados en los extremos del cuerpo central, capaces de proporcionar una difusión de la luz tanto directa como indirecta. Su carácter decorativo está subrayado por los paneles revestidos de tejido de punto ignífugo, que le dan personalidad y singularidad.

Our suggested mix



01



02



03



29



29



29



06



15



19



01



02



31







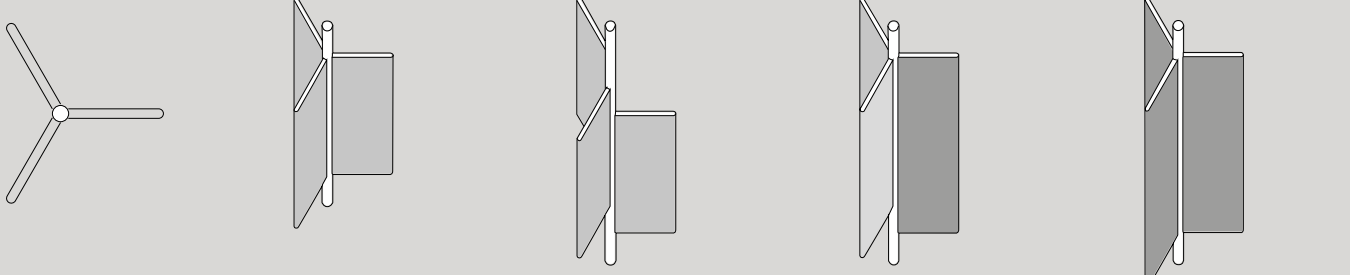
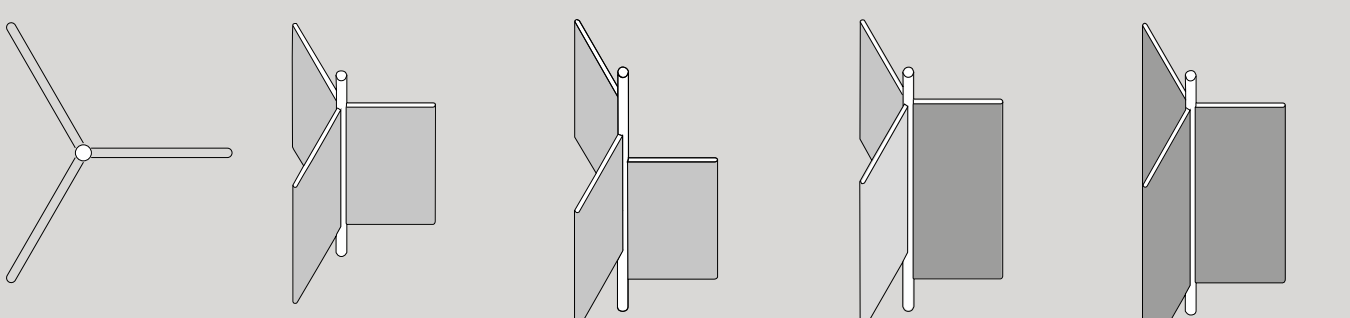





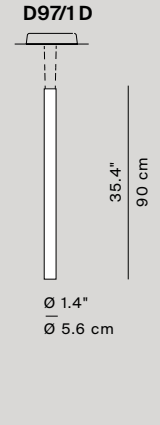
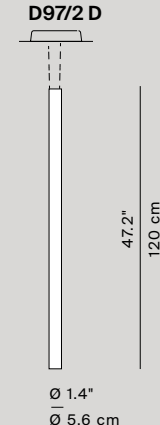
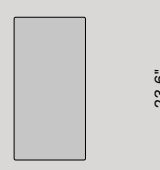
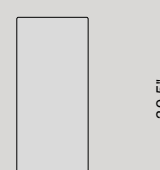
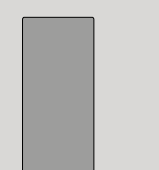
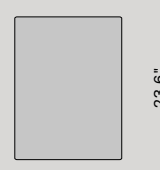
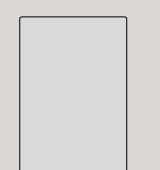
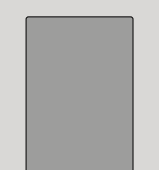



Suggested configurations

| | | | | |
|--|---|---|--|--|
| Panels 30 cm width | Body L 90 cm 3 panels 30 x 60 cm flat version | Body L 120 cm 3 panels 30 x 60 cm shift version | Body L 120 cm 1 panel 30 x 60 cm 1 panel 30 x 75 cm 1 panel 30 x 90 cm mixed version | Body L 120 cm 3 panels 30 x 90 cm flat version |
|  | D97/1D + 3 x D97C36 | D97/2D + 3 x D97C36 | D97/2D + 1 x D97C36 1 x D97C37 1 x D97C39 | D97/2D + 3 x D97C39 |
| Panels 45 cm width | Body L 90 cm 3 panels 45 x 60 cm flat version | Body L 120 cm 3 panels 45 x 60 cm shift version | Body L 120 cm 1 panel 45 x 60 cm 1 panel 45 x 75 cm 1 panel 45 x 90 cm mixed version | Body L 120 cm 3 panels 45 x 90 cm flat version |
|  | D97/1D + 3 x D97C46 | D97/2D + 3 x D97C46 | D97/2D + 1 x D97C46 1 x D97C47 1 x D97C49 | D97/2D + 3 x D97C49 |

D97

Trypta

| | | | |
|---|---|--|--|
| Structure D97/1D D97/2D direct/indirect light dimnable push/DALI | D97/1 D  35.4" 90 cm Ø 1.4" Ø 5.6 cm | D97/2 D  47.2" 120 cm Ø 1.4" Ø 5.6 cm | |
| Panels 30 cm width | D97C36  23.6" 60 cm | D97C37  29.5" 75 cm | D97C39  35.4" 90 cm |
| Panels 45 cm width | D97C46  23.6" 60 cm | D97C47  29.5" 75 cm | D97C49  35.4" 90 cm |
| Light source | D97/1D - D97/2D | | dim to warm LED module 2 x 20W 3000K CRI 97 |
| Materials | Structure in painted extruded aluminium, panels in acoustic material covered with flame retardant fabric | | |
| Structure finishes |  Matt alu |  Matt white | |
| Panel finishes | Standard collection  Light grey  Medium grey  Dark grey | | |
| | Solid collection  Peach  Orange  Mustard  Red  Brown | | |
| Insulation class |  CE | | |

Contact

Italy
Headquarters
Via E.T. Moneta 40
20161 Milano
T +39 02 66 242 1
F +39 02 66 203 400
N. verde 800 800 169
info@luceplan.com

USA
287 Park Ave South, NY
NY 10010
T (212) 334 1809
F (212) 334 7307
infous@luceplan.com

luceplan.com

Showroom

Milan
Corso Monforte 7
20122 Milano
T +39 02 76 015 760
F +39 02 78 4062
luceplanstore@luceplan.com

Copenhagen
Luceplan Professional Space
Dybendslvænget 2,
DK-2630 Taastrup (Copenhagen)
T +45 41 67 54 16
professionalspace@luceplan.com
Open by appointment only

For more information
on the sales network,
please visit luceplan.com
or send an email to
info@luceplan.com

© Luceplan 2020

Photography

Younes Bounhar
40
Santi Caleca
53
Andrea Pugiotto
60
Ivan Sarfatti
37
Studio 9010
9, 10, 16, 21, 23, 26, 27, 28, 33,
35, 55, 77, 79, 81

Styling

Monti-studio
9, 16, 21, 26, 27, 28, 33, 55, 77,
79, 81

Project coordination

Rosi Guadagno
Alessandro Benini

Print

Geca srl
S. Giuliano Milanese

Luceplan always strives out to provide the finest and most reliable technology. When innovation makes it possible to offer advantages for our clients, we revise and update our products. Therefore our technical catalogue and product data sheets are constantly in a state of evolution and ongoing change. If you are looking for technical specifications or the latest news on our offerings, please visit our official website luceplan.com. Luceplan reserves the right to introduce any changes to its own models without prior notice.

Da sempre Luceplan si pone l'obiettivo di proporre la miglior tecnologia disponibile. Rivediamo e introduciamo le innovazioni che costituiscono un vantaggio reale per i nostri clienti, aggiornando costantemente i nostri prodotti. Pertanto i dati tecnici del catalogo e dei prodotti sono in continua evoluzione. Per consultare i dati aggiornati e le novità più recenti sulle nostre collezioni, vi invitiamo a visitare il nostro sito ufficiale luceplan.com. Luceplan si riserva il diritto di apportare ai propri modelli qualsiasi modifica senza nessun preavviso.

1PN000090



8 056304 364326



luceplan.com